

A-3B - MM - 1/76

RADIO RECEIVER WITH SPECTRUM DISPLAY

MODEL A-3B



IMPORTANT NOTICE

IT IS IMPORTANT TO NOTE THAT THIS EQUIPMENT CONTAINS
INTERNAL VOLTAGE WHICH MAY BE HAZZARDOUS. MAINTENANCE
AND INSPECTION SHOULD ONLY BE PERFORMED BY QUALIFIED
TECHNICAL PERSONNEL UTILIZING PROPER SAFEGUARDS. REFER
TO THE WARNING LABEL SHOWN BELOW:

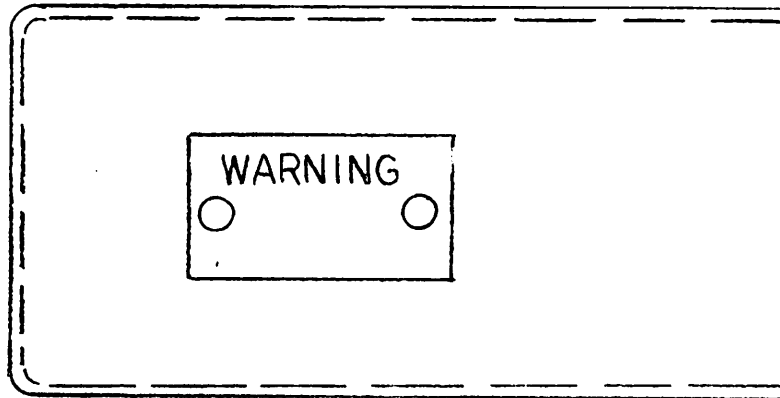

PS 10, 11 & 12 CASE



TABLE OF CONTENTS

Page No.

PART ONE: GENERAL DESCRIPTION

1.1	Description of A3B Receiver System	1-1
1.2	Modes of Operation	1-1
1.3	Components and Their Functions	1-1
1.4	Physical Characteristics	1-2

PART TWO: DESCRIPTION OF ACCESSORIES

2.1	Accessories Description	2-1
-----	-------------------------	-----

TABLE OF CONTENTS

Page No.

PART THREE: ELECTRICAL SPECIFICATIONS - RECEIVER MODES

3.1	Radio Frequency Coverage	3-1
3.2	AM Sensitivity	3-1
3.3	FM Quieting	3-1
3.4	IF Bandwidths	3-1
3.5	Bandwidth Slope Factor	3-1
3.6	Spurious Response Rejection	3-2
3.7	Oscillator Radiation	3-2
3.8	Antenna Input Impedance	3-2
3.9	FM Detection	3-2
3.10	BFO	3-2
3.11	Audio Output	3-2
3.12	Dials	3-2
3.13	IF Output	3-3
3.14	Post Detection Output	3-3
3.15	Signal Strength Meter	3-3
3.16	Battery Supply	3-3
3.17	AC Power Supply	3-3
3.18	Oscillations	3-3
3.19	CW Desensitization	3-4
3.20	Operating Temperature	3-4
3.21	Bandsread	3-4

TABLE OF CONTENTS

Page No.

PART FOUR: ELECTRICAL SPECIFICATIONS-VISUAL DISPLAY MODES

4.1	Dispersion and Calibration	4-1
4.2	Frequency Linearity	4-1
4.3	Resolution	4-1
4.4	Sweep Rate Calibration	4-1
4.5	Sweep Linearity	4-1
4.6	Audio Limitation in Spectrum Mode	4-1
4.7	Screen Size	4-1
4.8	Signal Gain Control	4-2
4.9	Sensitivity	4-2
4.10	Dynamic Range	4-2
4.11	Spurious Response	4-2
4.12	Video Bandwidth	4-2
4.13	Phosphor	4-2
4.14	Tuner Sweep Mode	4-2
4.15	Scope Mode	4-2

TABLE OF CONTENTS

Page No.

PART FIVE: THEORY OF OPERATION

5.1	INTRODUCTION	5-1
5.2	HIGH FREQUENCY RECEIVER (30100-.3 to 1600 MHz)	5-1
5.2.1	111 MHz to 23.5 MHz Converter	5-1
5.2.2	Bandwidth Determination	5-1
5.2.3	23.5 MHz IF Amplifier	5-1
5.2.4	AM Detector	5-1
5.2.5	FM Detector	5-2
5.2.6	Signal Strength Meter	5-2
5.2.7	Audio Amplifier	5-2
5.2.8	Sweep Amplifier	5-2
5.3	HIGH FREQUENCY TUNERS	5-2
5.3.1	Tuner TA3-1 (.3-1 MHz)	5-3
5.3.2	Tuner TA3-2 (1-3.5 MHz)	5-3
5.3.3	Tuner TA3-3 (3.5-12 MHz)	5-3
5.3.4	Tuner TA3-4 (12-43 MHz)	5-3
5.3.5	Tuner TA3-5 (43-130 MHz)	5-4
5.3.6	Tuner TA3-6 (130-420 MHz)	5-4
5.3.7	Tuner TA3-7 (420-800 MHz)	5-4
5.3.8	Tuner TA3-8 (800-1600 MHz)	5-4
5.4	LOW FREQUENCY RECEIVER (30200-2 to 300 KHz)	5-5
5.4.1	TA3-03B Tuner	5-5
5.4.2	Swept Converter (C-2)	5-5
5.4.3	Basic Low Frequency Unit (B-2)	5-6
5.4.3.1	455 KHz Amplifier, Emitter Follower and Bandpass Filter	5-6
5.4.3.2	455 KHz Amplifier String, AM Detector and S Meter	5-6
5.4.3.3	Video Detector	5-6
5.4.3.4	FM Limiter and Detector	5-6
5.4.3.5	Audio Amplifier	5-6
5.4.3.6	455 KHz Beat Frequency Oscillator	5-7
5.5	VISUAL DISPLAY UNIT (S-3)	5-7
5.5.1	Sawtooth Sweep Generator	5-7
5.5.2	Vertical Amplifier	5-7
5.5.3	Horizontal Amplifier	5-7
5.6	AC POWER SUPPLY PS-10	5-8
5.7	BATTERY PACK ASSEMBLY BP-7	5-8

TABLE OF CONTENTS

Page No.

PART SIX: OPERATING PROCEDURE

6.1	Low Frequency Receiver Mode	6-1
6.2	High Frequency Receiver Mode	6-1
6.3	Panadapter Mode	6-2
6.4	Tuner Scanning Mode	6-5
6.5	Double Detect Mode	6-6
6.6	Video Mode	6-8
6.7	Remote Tuner Mode	6-9
6.8	Oscilloscope Mode	6-9

PART SEVEN: REPAIR AND ALIGNMENT OF COMPONENT PARTS

7.1	Scope	7-1
7.2	B-1 HFR Main Chassis	7-2
7.3	C-1 111 to 23.5 MHz Converter	7-5
7.4	TA3-1 Tuner (.3 - 1 MHz)	7-7
7.5	TA3-2 Tuner (1 - 3.5 MHz)	7-9
7.6	TA3-3 Tuner (3.5 - 12 MHz)	7-11
7.7	TA3-4 Tuner (12 - 43 MHz)	7-13
7.8	TA3-5 Tuner (43 - 130 MHz)	7-15
7.9	TA3-6 Tuner (130 - 220, 220 - 420 MHz)	7-16
7.10	TA3-7 Tuner (420 - 800 MHz)	7-19
7.11	TA3-8 Tuner (800 - 1600 MHz)	7-21
7.12	B-2 LFR Main Chassis	7-23
7.13	C2 23.5 MHz to 455 KHz Converter	7-25
7.14	TA3-03B Tuner (2 - 300 KHz)	7-27
7.15	S-3 Visual Display Unit	7-29
7.16	PS-10 AC Power Supply	7-31
7.17	BP-7 Battery Pack	7-32

TABLE OF CONTENTS

Page No.

PART EIGHT: OPERATIONAL TESTS, RECEIVER MODES

8.1	AM Sensitivity and Dial Accuracy	8-1
8.2	FM Quieting	8-2
8.3	Bandspread (Fine Tune)	8-3
8.4	IF Rejection	8-3
8.5	Image Rejection	8-3
8.6	Oscillator Radiation	8-3
8.7	IF Bandwidths	8-4
8.8	Sweep Width	8-5
8.9	Sweep Rate	8-6
8.10	S3 Vertical Sensitivity	8-6
8.11	Signal Gain Control	8-6
8.12	Video Bandwidth	8-6
8.13	Z Axis Sensitivity	8-6
8.14	Brightness Control	8-7
8.15	Focus Control	8-7
8.16	Sweep Centering Control	8-7
8.17	Signal Centering Control	8-7
8.18	Sync Control	8-7
8.19	External Sync Jack	8-7
8.20	Sweep Gain Control	8-7
8.21	LFR Hi-Low Meter Switch	8-7
8.22	LFR IF Gain Control	8-8
8.23	LFR AGC Test Jack	8-8
8.24	LFR Detect out Jack	8-8
8.25	LFR Audio Output	8-8
8.26	LFR IF Out Jack	8-8
8.27	LFR BFO Test	8-8
8.28	HFR Hi-Low Meter Switch	8-8
8.29	HFR IF Gain Control	8-9
8.30	HFR AGC Test Jack	8-9
8.31	HFR Detect Output and Swp Jack	8-9
8.32	HFR Audio Output	8-9
8.33	HFR BFO Test	8-9
8.34	BP7 Battery Pack Test	8-9
8.35	Accessory Check	8-9

NOTE: PART NINE incorporated into Part 8 9/71)

TABLE OF CONTENTS

Page No.

PART TEN: OPERATING DIAGRAM

10.1	Operating Diagram	10-1
------	-------------------	------

PART ELEVEN: SCHEMATIC WIRING DIAGRAMS

Figure	Title	Drawing No.
11.1	Block Diagram A3 System	30000-x
11.2	B1/C1 Basic Unit (High Freq. Receiver)	SWD 4048 D
11.3	TA3-1 Tuner (" " ")	SWD 4023 B
11.4	TA3-2 Tuner (" " ")	SWD 4024 B
11.5	TA3-3 Tuner (" " ")	SWD 4025 B
11.6	TA3-4 Tuner (" " ")	SWD 4026 B
11.7	TA3-5 Tuner (" " ")	SWD 4027 B
11.8	TA3-6 Tuner (" " ")	SWD 4028 C
11.9	TA3-7 Tuner (" " ")	SWD 4046 C
11.10	TA3-8 Tuner (" " ")	SWD 4047 C
11.11	SB1 Switch Board (" " ")	SWD 4056 C
11.12	B2 Basic Unit (Low Freq. Receiver)	SWD 4031 B
11.13	C2 Swept Converter (" " ")	SWD 4033/35 C
11.14	TA3-03B Tuner (" " ")	SWD 4073 B
11.15	Vert. Amp. and Sawtooth Sweep Gen. S3 Monitor	SWD 4038 C
11.16	Horz, Amp. S3 Monitor	SWD 4039 C
11.17	High Voltage Divider S3 Monitor	SWD 4042 B
11.18	PS10 AC Power Supply	SWD 4074 B
11.19	High Voltage Converter S3 Monitor	SWD 4077 B

TABLE OF CONTENTS

PART TWELVE: PICTORIAL WIRING AND ASSEMBLY DIAGRAMS

Figure	Title	Drawing No.
12.1	Harness, Interconnecting	6811-D
12.2	High Frequency Receiver Assembly	30100-D
12.3	" " " Switch Board Assembly	30102
12.4	" " " Basic Unit B1/C1-1	PWD 30106-1x (3 Pages)
12.5	" " " TA3-1 Assembly	30110-C
12.6	" " " TA3-1 RF Cover Assembly	30116-B
12.7	" " " TA3-1 PC Board Assembly	PWD 4023-D
12.8	" " " TA3-2 Assembly	30115-C
12.9	" " " TA3-2 RF Cover Assembly	30117-B
12.10	" " " TA3-2 PC Board Assembly	PWD 4024-C
12.11	" " " TA3-3 Assembly	30120-C
12.12	" " " TA3-3 RF Cover Assembly	30118-B
12.13	" " " TA3-3 PC Board Assembly	PWD 4025-C
12.14	" " " TA3-4 Assembly	30125-C
12.15	" " " TA3-4 RF Cover Assembly	30119-B
12.16	" " " TA3-4 PC Board Assembly	PWD 4026-D
12.17	" " " TA3-5 Assembly	30130-C
12.18	" " " TA3-5 RF Cover Assembly	PWD 30133-B
12.19	" " " TA3-5 PC Board Assembly	PWD 4027-C
12.20	" " " TA3-6 Assembly	30135-D
12.21	IF Preamp TA3-6	PWD 4068-B
12.22	RF Amp. TA3-6	30139-B
12.23	High Frequency Receiver Tuner TA3-7 Assembly	30140-D
12.24	" " " IF PC Board Assembly	PWD 4029-B
12.25	" " " Tuner TA3-8 Assembly	30150-D
12.26	Low Frequency Receiver Assembly	30200-D
12.27	" " " 455 KHZ IF PC Board Ass'y B2-1	PWD 4031-D
12.28	" " " Audio/BFO PC Board Ass'y B2-2	PWD 4032-C
12.29	" " " Panel Assembly	PWD 30215
12.30	" " " Wiring Assembly	PWD 30205
12.31	" " " Swept Converter PC Board Ass'y C2-1	PWD 4033-C
12.32	" " " Swept Converter PC Board Ass'y C2-2	PWD 4034-C
12.33	" " " Swept Converter PC Board Ass'y C2-3	PWD 4035-C
12.34	" " " Tuner TA3-03B Assembly	30250-D
12.35	" " " Tuner TA3-03B PC Board Ass'y	PWD 4073-C
12.36	Visual Monitor Assembly	30300-C
12.37	" " " S-3 Front Cover Assembly	30310-D
12.38	" " " Vertical Amp. PC Board Assembly	PWD 4038-C
12.39	" " " Horizontal Amp. PC Board Assembly	PWD 4039-C
12.40	H. V. Converter S3 Monitor	PWD 4077-C
12.41	Power Supply PS-10 Assembly	30410-D
12.42	" " " PS-10 High Voltage Board Assembly	PWD 4074-C
12.43	Battery Pack BP-7 Assembly	30460

TABLE OF CONTENTS

PART THIRTEEN: TEST SET UP DIAGRAMS

- 13.1 RF Coverage, AM Sensitivity, FM Quieting, Spurious Response Rejection
Dial Calibration, % Distortion, Signal Meter
- 13.2 IF Bandwidths, Slope Factor, FM discriminator, Bandsread
- 13.3 Spurious Response
- 13.4 Power Supply
- 13.5 CW Desensitization

PART FOURTEEN: TEST DATA FORMS

Title	Data Sheet
Sensitivity and Dial Accuracy	A
Quieting, Sweep Width, IF Rejection, Image Rejection, L.O. Radiation, AGC Tests	B
IF Response curves, Audio, BFO Sweep-Width Tests	C
Miscellaneous Tests	B



PART ONE: GENERAL DESCRIPTION**1.1 DESCRIPTION OF A-3B RECEIVER SYSTEM:**

The model A-3B Radio Receiver is a portable, miniature, wide frequency coverage instrument with visual display having versatile signal reception, processing and read out functions. The low and high frequency units are usable separately as receivers and the visual display unit is usable as a utility oscilloscope. Together, in various combinations, they are usable in the modes described in Paragraph 1.2. It differs somewhat from the original A-3, mainly concerning the AC power supply (PS-10) and the S3 monitor.

1.2 MODES OF OPERATION:

1.2.1 Receiver Mode: Both the low and the high frequency receiver and power supply are usable as a straight receiver with audio and "S" meter outputs.

1.2.2 Double Detect Mode: Detected output of high frequency receiver is fed to input of low frequency receiver for second detection.

1.2.3 Panadapter Mode: A converter is provided to permit use of the low frequency IF unit and signal analyzer in a conventional "Pan-Adapter" mode. RF coverage in this mode is .3 to 1600 MHz. Simultaneous audio and spectrum display "readouts" are possible in this mode.

1.2.4 Tuner Scanning Mode: The visual display unit used with either receiver provides uncalibrated spectrum display outputs. Audio and visual outputs are not to be monitored simultaneously in this mode.

1.2.5 Video Mode: The visual display unit is usable to display the detected output of either receiver.

1.2.6 Oscilloscope Mode: The visual display unit is usable separately as a Utility Oscilloscope.

1.2.7 All of the above modes are operable without removing any components from the carrying case.

1.2.8 Remote Tuner Operation: Individual tuners may be removed and cable connected with receiver to allow remote tuner operation.

1.3 COMPONENTS AND THEIR FUNCTION:

1.3.1 High Frequency Receiver: This receiver provides signal reception from .3 to 1600 MHz and processes the signal through amplification, filtering,

detection-to-Audio and signal meter read-out. This unit also provides outputs for double detect and visual displays as per Paragraph 1.2.2 to 1.2.5. This unit consists of eight (8) tuning heads, 23.5 MHz IF amplifier with selectable filters, 111/23.5 MHz converter, AM, and FM detectors, BFO, audio amplifier and signal strength meter. It does not contain a power source.

1.3.2 Low Frequency Receiver: This receiver provides signal reception from 2 to 300 KHz and processes the signal through amplification, filtering, detection-to-audio and signal meter read-out. This unit also provides for double detection and visual displays as per Paragraphs 1.2.2 to 1.2.5. The unit consists of one tuning head, 455 KHz IF amplifier with selectable filters, AM and FM detectors, BFO, audio amplifier, signal meter and 23.5/.455 MHz voltage tunable converter for panadapter mode. This unit does not contain a power source.

1.3.3 Battery Pack: Two battery packs are provided containing easily replaceable batteries. These packs are capable of providing power to any one or all of the two receivers and visual display unit.

1.3.4 AC Power Supply: This unit supplies any one or all of the two receivers and visual display unit from a 115V \pm 20V or 230V \pm 30V 50 to 60 Hertz AC line. The AC power supply also contains the power line antenna circuit.

1.3.5 Accessories: Accessories include antennas, cables, carrying case, manuals, tools, attenuators, etc.

1.3.6 Visual Display Unit: The visual display unit provides CRT read-out, associated horizontal, vertical and power conversion circuitry needed to process receiver output for frequency spectrum and video display. In addition, the unit provides ramp generator output with appropriate bias voltage to drive voltage tunable oscillators in the receiver sections.

1.4 PHYSICAL CHARACTERISTICS:

1.4.1 Case: All components are carried in a 12" x 17" x 6" case except for the maintenance manual.

1.4.2 Weight: Weight is less than 32 pounds with batteries.

1.4.3 Configuration: All units are operable in the case with all controls, jacks, dials and read-outs in the horizontal plane except the visual display unit which is in the lid of the case with a vertical plane panel. The display screen image appears in this vertical plane. Interconnecting cables are used to facilitate various modes of operation.

- 1.4.4 All controls and connectors are clearly and permanently marked. Each tuning head is marked indicating frequency range.
- 1.4.5 IF output frequencies are marked near IF output BNC connectors.
- 1.4.6 The gain control positions are graduated to indicate position.
- 1.4.7 All receiver and visual display unit markings are exposed when units are stored in the attache' case with the lid open.
- 1.4.8 The battery pack schematic diagram, together with substitution battery types and voltages, are displayed on the battery pack.
- 1.4.9 All screws are locked with break-away adhesive (such as Loctite). This, however, does not preclude the removal of same for equipment repair.

PART TWO: DESCRIPTION OF ACCESSORIES

2.1 ACCESSORIES

The following accessories are provided.

	Item	Quantity
2.1.1	Earphone with cord	1
2.1.2	Whip Antenna	1
2.1.3	Bow Tie Antenna with extenders	1
2.1.4	Ferrite Rod Antenna #1 (2 - 300 KHz)	1
2.1.5	Ferrite Rod Antenna #2 (: 3 - 30 MHz)	1
2.1.6	Long Wire Antenna	1
2.1.7	Blocking Capacitor	1
2.1.8	20 dB Attenuator Pad	2
2.1.9	BNC Male/Male adapter	1
2.1.10	BNC Female/Female adapter	1
2.1.11	European Power plug adapter #1	1
2.1.12	European Power plug adapter #2	1
2.1.13	Five foot BNC cable	1
2.1.14	One foot BNC cable	1
2.1.15	Power Cable	1
2.1.16	Remote Tuner Cable	1
2.1.17	Manual	1
2.1.18	Tool, common screwdriver	1
2.1.19	Tool, Phillips Screwdriver	1
2.1.20	Allen wrench	1
2.1.21	Spline Key	1
2.1.22	Attache Case	1
2.1.23	Attache Case insert #1 Lower	1
2.1.24	Attache Case insert #2 Lid, large	1
2.1.25	Attache Case insert #3 Lid, small	1
2.1.26	Attache Case insert #4 (S3 Pads)	2
2.1.27	Interconnecting harness	1
2.1.28	Spinner knob	1
2.1.29	AC 3 wire to 2 wire adapter	1

PART THREE: ELECTRICAL SPECIFICATIONS RECEIVER MODE

3.1 Radio Frequency Coverage:
2 KHz to 1600 MHz

3.2 AM Sensitivity:

RF	IF BW	Max. Input	For Output of
2 KHz - 80 KHz	200 Hz	1.5 uv (CW)	25% S Meter Deflection
80 KHz - 300 KHz	2 KHz	1.5 uv*	10 dB of $\frac{S+N}{N}$
.3 - 130 MHz	20 KHz	1.5 uv*	" N
130 - 400 MHz	20 KHz	2.0 uv*	"
400 - 800 MHz	90 KHz	2.5 uv*	"
800 - 1600 MHz	90 KHz	3.5 uv*	"

* Input signal 30% amplitude modulated with 1000 Hz signal.

3.3 FM Quieting:

RF	IF BW	Max. Input for 20 dB of Audio Output Quieting
2 - 5 KHz	(FM Inoperable)	
5 - 300 KHz	2 KHz	3 uv
.3 - 12 MHz	20 KHz	5 uv
12 - 400 MHz	90 KHz	7 uv
400 - 800 MHz	90 KHz	10 uv
800 - 1600 MHz	90 KHz	15 uv

3.4 IF Bandwidths Selectable:

RF	Bandwidth At - 6 dB Points
2 - 5 KHz	.2 KHz
5 - 15 KHz	.2 and 2 KHz
15 - 300 KHz	.2, 2, and 10 KHz
.3 - 1 MHz*	2 and 20 KHz
1 - 10 MHz*	2, 20, and 90 KHz
10 - 1600 MHz*	2, 20, 90, and 1000 KHz

* These RF ranges also have .2 and 10 KHz available by using converter located in the LF Receiver although usability is limited by L. O. stability. It should further be noted that full IF bandwidths may not be realized at all RF's because of narrow RF selectivity.

3.5 Bandwidth Slope Factor:

The slope factor; bandwidth at 50 dB point divided by bandwidth at 6 dB point, is 2.6:1 or less, except in 1 MHz position.

3.6 Spurious Response Rejection:

All spurious response rejections, including IF and Image, and internally generated signals, are as follows:

RF	Minimum Rejection
2 - 300 KHz	50 dB
.3 - 12 MHz	80 dB
12 - 130 MHz	50 dB
130 - 1600 MHz	40 dB

Note: Rejection levels are measured to an RF level reference of 3 uv or less.

3.7 Local Oscillator Radiation:

Local oscillator voltage level measured at the antenna terminal is less than -60 DBM for RF of 2KHz to 130 MHz and less than -50 DBM for RF of 130 to 1200.

3.8 Antenna Input Impedance:

50 ohms nominal.

3.9 FM Detection:

FM discriminators are provided for all frequencies from 5 KHz to 1600 MHz, however, in the 200 Hz bandwidth position of the low frequency receiver and the 2 KHz bandwidth position of the high frequency receiver, the discriminators may not be usable.

3.10 BFO:

A crystal controlled BFO is provided in the HF receiver which also acts as a center marker for the panadapter mode. A tunable BFO is provided for the LF receiver.

3.11 Audio Output:

Audio output level is 6.5 mw minimum undistorted output into a 1000 ohm load. Harmonic distortion is less than 3%. For this measurement, the input is a 30 uv signal, 30% amplitude modulated by 1 KHz. Receiver is set in AM, with manual IF gain set for red line on "S" meter (LO S-meter range) and AF gain set for rated output (6.5 mw). This specification does not apply to the 200 Hz IF bandwidth position.

3.12 Dial:

Dials are direct reading and have an accuracy of plus or minus 1.5% or 1/8 inch dial displacement whichever is greater. Tuning controls have good positive control with a

maximum of 45 degrees of mechanical backlash.

3.13 IF Output:

Undetected IF output is provided at a bandwidth of 20 KHz minimum for an RF center frequency of 20 KHz to 3 MHz, a bandwidth of 90 KHz minimum for an RF center frequency of 3 to 40 MHz, and a bandwidth of 2 MHz minimum for an RF center frequency of 40 to 1600 MHz. Bandwidths are measured at the 6 dB points. Level is 25 uv for 2 uv input signal.

3.14 Post Detection Output:

One-at-a-time detected IF, AM and FM outputs are provided. (FM detection subject to exceptions as noted in Paragraph 3.9).

3.15 Signal Strength Meter:

A signal strength meter indicating relative field strength of all incoming signals, modulated or unmodulated, is provided with low and high level switch. Also, the meter is used to indicate battery and power supply conditions. A redline is positioned on the meter to indicate the battery or AC power supply cutoff point.

3.16 Battery Supply:

Battery packs are supplied which will operate all units for 25 hours or more. They operate one receiver for over 100 hours. Batteries are held in containers separate from the rest of the receivers to insure against leakage, corrosion, and shorting damage. The equipment is so designed that the connecting power cable must be removed when case lid is closed to prevent accidental "on" operation while stored. When using the visual display unit with receivers, use both battery packs to greatly extend operating time. This is important and is required to operate panadapter system for over 25 hours.

3.17 AC Power Supply:

An AC power supply for use in lieu of the batteries is supplied with input of $115V \pm 20V$ or $230V \pm 30V$, 50/60 Hz and provides power for all circuits. The AC power supply is isolated from the AC power mains to eliminate any possible shock hazard to user. A power line to antenna input matching circuit is located in the AC supply thereby using the same power cord and plug. A BNC jack is located on the panel for cable connection to the tuners.

3.18 Oscillation:

The receiver system will not self-oscillate at any dial frequency setting of any head regardless of input or output loads.

3.19 CW Desensitization:

Tests for CW desensitization are made according to the procedure outlined in Mil-STD-449C, Procedure 5.3.11. The resulting curve has the following shape factor or better between the 12 dB and 30 dB points:

RF range 2 KHz to 5 KHz, less than 3:1 frequency slope, with 12 dB points less than 10% of test frequency.

RF range 5 KHz to 1 MHz, less than 3:1 frequency slope, with 12 dB points less than 5% of the test frequency.

RF range of 1 to 1600 MHz, less than 6:1 frequency slope, with 12 dB points less than 1% of the test frequency.

3.20 Temperature Range:

All components operate from 30 to 122 degrees F except for the battery cells provided. The operating temperatures of the cells provided are 50 to 122 degrees F.

3.21 Bandsread and/or Fine Tuning:

Bandsread is provided for all RF frequencies. Bandsread range is equal to or more than 0.2% of the RF frequency from 2 KHz to 420 MHz and .02% from 420 MHz to 1600 MHz.

PART FOUR: ELECTRICAL SPECIFICATIONS-VISUAL DISPLAY MODES**4.1 Dispersion and Calibration:****4.1.1 Panadapter Mode:**

Panadapter mode dispersion is as follows: RF .3 to 12 MHz, 3 selectable dispersions between 2 KHz and 80 KHz. RF 12 MHz to 1600 MHz, 6 selectable dispersions from 2 KHz to 5 MHz. Dispersion in panadapter mode is calibrated and so marked on the dispersion switch control. At some RF frequencies, dispersion may be limited by RF selectivity.

4.1.2 Tuner Sweep Mode:

RF 2 to 300 KHz, a maximum of at least 200 KHz dispersion provided. RF .3 to 1600 MHz, an uncalibrated tuner sweep mode is supplied.

4.2 Frequency Linearity:

$\pm 8\%$ of dispersion width, applicable in panadapter mode only.

4.3 Resolution:

Panadapter mode analyzer bandwidths are 200 Hz, 2 KHz, and 10 KHz. Selectable.

4.4 Sweep Rate Calibration:

Sweep rates are provided from 1/10 sec/cm to 2 us/cm continuously adjustable by overlapping switched ranges and vernier adjust control. Sweep rate versus control setting calibration is so marked on display unit panel.

4.5 Sweep Time Linearity:

The sweep time vs. the display spot displacement at calibrated rate positions is within $\pm 8\%$ of that predicted on the basis of a linear sweep.

4.6 Audio Limitation in Spectrum Mode:

Simultaneous audio and visual outputs are not provided when operating in the "Tuner Scanning" mode.

4.7 Screen Size:

Display screen is 1" x 3" rectangular.

4.8 Signal Gain Control:

Manual signal gain control is provided with 50 dB range.

4.9 Sensitivity:

Minimum detectable visual output is equal to or less than minimum detectable audio signal output.

4.10 Dynamic Range:

Signal display unit in panadapter mode is able to display incoming signals of 30 dB level differential simultaneously at maximum resolution.

4.11 Spurious Response:

The display is free of signals other than those received at the antenna terminal up to input signal levels of 10 mv.

4.12 Video Bandwidth:

Bandwidth of vertical display amplifier is approximately 1 Hz to 1.8 MHz at 3 dB points.

4.13 Phosphor:

P1 phosphor is used.

4.14 Tuner Sweep Mode:

Circuitry is provided to enable user to spectrum display signals employing either one of the receivers and the signal display unit in the tuner scanning mode. (See Paragraph 4.6 for audio limitation in this mode).

4.15 Scope Mode:

The visual display unit is capable of use as a utility oscilloscope with specifications cited in Paragraph 4.4, 4.5, 4.7, 4.8, 4.12 and 4.13. Vertical gain is 2 mv/cm. Synchronizing control is provided with external/internal switch and jack. Z axis input is also provided.

PART FIVE: THEORY

5.1 INTRODUCTION:

The component parts of the A-3B Receiver System are shown in the block diagram of Figure 11-1. The A-3B consists of five (5) basic units: High Frequency Receiver, Low Frequency Receiver, Visual Display Unit, Battery Pack and AC Power Supply.

5.2 HIGH FREQUENCY RECEIVER: (30100 .3-1600 MHz)

The High Frequency Receiver is shown schematically in Drawing SWD-4048-D, Figure 11.2. The bandswitch selects the tuner operating in the frequency range to be covered and applies DC power to the tuner while simultaneously completing the RF connection between the tuner output and the converter for Tuners 4, 6, 7 and 8, or the IF Amplifier in the case of Tuners 1, 2, 3, and 5. Refer to drawing SWD-4056C, Figure 11.11 for details of the bandswitch.

5.2.1 111 MHz to 23.5 MHz Converter

The converter mixes the 111 MHz signal with a local oscillator signal from the 87.5 MHz crystal controlled oscillator. A band stop filter consisting of L7 and C52 is tuned to 151 MHz to prevent the local oscillator of tuner TA3-4 from entering the converter. A two stage amplifier tuned to 111 MHz supplies approximately 6 dB gain and the output of the second stage is coupled to the balance mixer. The 23.5 MHz signal passes through a low pass output filter to remove any residual 87.5 MHz signal from the local oscillator. Since Tuners 1, 2, 3 and 5 have outputs at 23.5 MHz, the preceding is not necessary when they are in use. J110 and P110 furnish the interconnection with the bandswitch.

5.2.2 Bandwidth Determination

Bandwidth is determined by the selection of either the 2 KHz, 20 KHz or 90 KHz crystal filter by means of the panel mounted four position switch. A fourth position allows straight through operation with a bandwidth of 1 MHz.

5.2.3 23.5 MHz IF Amplifier

The IF amplifier consists of transistors Q1 through Q5. Q1 utilizes a 3N140 insulated gate field effect transistor with AGC applied to gate #2. The following four (4) IF stages use 3N128 IGFETS. The interstage transformers are tunable and have a bandwidth greater than 1 MHz.

5.2.4 AM Detector

AM detection is accomplished by CR4 and CR5. The detected audio is fed through S7 to the audio amplifier. The AGC tap furnishes AGC voltage to the first IF amplifier and the RF stages in Tuners 1, 2, 3 and 4.

5.2.5 FM Detector

Q6 and Q7 serve as limiters for the signal. Two discriminators are employed. CR6 and CR7 form a wide band discriminator having a bandwidth of approximately 350 KHz while a crystal discriminator having a bandwidth of 90 KHz is used for narrow bandwidth FM signals. The discriminator to be used is selected with panel switch S6.

5.2.6 Signal Strength Meter

The S Meter gives a signal strength indication for both AM and FM signals. Maximum S Meter excursion may be controlled by the S Meter sensitivity switch S-3. The S Meter also serves to test the condition of the PS-10 AC Power Supply or the BP-5 battery pack by placing a load (R30) on the voltage terminals of the Power Supply and observing the current drawn through the S Meter. CR3 provides protection in the event the wrong polarity is applied to the input voltage jack, J15.

5.2.7 Audio Amplifier

A two stage audio amplifier consisting of Q8 and Q9 furnishes a minimum of 6.5 mw undistorted output through jack J16. The output impedance is 1000 ohms. Audio output volume is adjustable by panel control R31.

5.2.8 Sweep Amplifier

The sweep amplifier receives a sweeping voltage through J21 from the Visual Display Unit. Q10 is also used as an isolation amplifier to prevent the loading of the sweep generator. After amplification, the sweep voltage is applied to the local oscillator of the Tuner in use through J113. This will be covered more completely in Section 5.5 concerning the Visual Display Unit.

5.3 HIGH FREQUENCY TUNERS:

TA3-1	.3 to 1 MHz
TA3-2	1 to 3.5 MHz
TA3-3	3.5 to 12 MHz
TA3-4	12 to 43 MHz
TA3-5	43 to 130 MHz
TA3-6	130 to 420 MHz
TA3-7	420 to 800 MHz
TA3-8	800 to 1600 MHz

The tuner to be used is selected by the bandswitch S8 located on the front panel of the High Frequency Receiver. The appropriate antenna must be connected to the tuner in use. Power is applied to each tuner through the

bandswitch. Only one tuner may be used at a time since the unused local oscillators are disabled to prevent interference to the band being surveyed. Provision is made for external tuners to be used provided they have an I. F. of 111 MHz.

Bandspreading may be accomplished electrically by means of a potentiometer mounted on the front panel. Tuning variation of approximately 0.2% may be had by means of the bandspread control.

5.3.1 Tuner TA3-1 (.3 - 1 MHz)

Refer to drawing SWD-4023-B, Figure 11.3. Q1 is a dual gate EGFET which serves as an RF amplifier for the signals within the tuning range of tuner T1. Both the input and output are tunable and tracked with the local oscillator by sections of C26. Gate #2 is used to apply AGC or manual gain control to the amplifier. T2 couples the RF signal to the balanced mixer.

The local oscillator furnishes a signal voltage to the balanced mixer which tunes over the frequency range of 23.8 MHz to 24.5 MHz. This frequency can be adjusted over a small range by the bandspread voltage introduced at the base of Q2 and controlled by the bandspread control mounted on the front panel. Sweeping voltage which is used to electronically sweep the local oscillator for scanning with the Visual Display Unit when used in the Tuner Sweep Mode is also injected at the base of Q2. The 23.5 MHz output of the balanced mixer is applied to the first IF amplifier through P-101.

5.3.2 Tuner TA3-2 (1-3.5 MHz)

Refer to drawing SWD 4024B, Figure 11.4. The circuit description of the TA3-2 is similar to that of the TA3-1 except that an active mixer using an IGFET is utilized. The local oscillator tunes a frequency range of 24.5 to 27 MHz. The IF output frequency is 23.5 MHz.

5.3.3 Tuner TA3-3 (3.5 - 12 MHz)

Refer to drawing SWD 4025B, Figure 11.5. The circuit description of the TA3-3 follows that of the TA3-2 except that the local oscillator tuning range is 27 to 35.5 MHz.

5.3.4 Tuner TA3-4 (12 - 43 MHz)

Refer to drawing SWD 4026B, Figure 11.6 for circuit functions. The local oscillator tunes 123 to 154 MHz. The IF output frequency is 111 MHz to prevent the RF amplifier from tuning through the IF frequency which would occur if the IF were 23.5 MHz. The output of the TA3-4 is applied to the 111 MHz IF amplifier.

5.3.5 Tuner TA3-5 (43 - 130 MHz)

Refer to drawing SWD 4027B, Figure 11.9. The local oscillator tunes from 66.5 to 153.5 MHz. An IF frequency of 23.5 MHz is used to avoid tuning the RF through the 111 MHz intermediate frequency. There is no provision for AGC in the TA3-5. The Mixer is an IGFET (Q2).

5.3.6 Tuner TA3-6 (130 - 420 MHz)

Refer to drawing SWD 4028C, Figure 11.8. The TA3-6 Tuner covers the frequency range of 130 to 420 MHz in two bands of 130 to 230 MHz and 230 to 420 MHz. SW1 switches the intermediate frequency signal output and the 15V collector voltage between the two local oscillators and the two RF amplifiers. SW2 switches the RF signal and the bandsread/tuner sweep signal voltage to the oscillator section which is being used.

In each band the RF is selected by 3 tank circuits. An RF amplifier is located between the first and second RF tank circuits in each case to improve sensitivity and local oscillator-to-antenna isolation. A common I. F. amplifier (111 MHz) is provided for added gain.

The local oscillators tune the frequency range of 241 to 341 MHz and 341 to 531 MHz. The unused oscillator is made inoperative by SW1 removing the collector bias. Each band has its own balanced mixer. The intermediate frequency is 111 MHz.

5.3.7 Tuner TA3-7 (420 - 800 MHz)

Refer to drawing SWD 4046C, Figure 11.9. The local oscillator tunes 531-911 MHz. Q2 is an RF amplifier which is tuned by a section of Variable Capacitor, C5. A balanced mixer BM1 is used. A 111 MHz IF amplifier is included in the tuner section.

5.3.8 Tuner TA3-8 (800-1600 MHz)

Refer to drawing SWD 4047, Figure 11.10. There is no RF amplification in the TA3-8 Tuner. To provide sufficient isolation of the LO signal from the antenna, a four stage tunable filter is used. The oscillator, Q1-M tunes 455.5 to 855.5 MHz. The mixer consists of DM1, a Schottky Barrier diode, R5 and the coupling loop in parallel with R5. The Mixer diode also serves as a frequency doubler and therefore the local oscillator signal seen by the mixer tunes from 911 to 1711 MHz. R5 is necessary to dampen resonances due to the inductance of the coupling loop and the capacitance of the mixer diodes. A 111 MHz IF preamplifier is included in the TA3-8 Tuner.

5.4 LOW FREQUENCY RECEIVER (30200):

The low Frequency Receiver (LFR) tunes the frequency range from 2 to 300 KHz. It also provides double detection and visual displays when used in conjunction with the High Frequency Receiver and the visual display unit. The LFR is shown schematically in drawing SWD 4031B, Figure 11.12.

The LFR will be broken down into three basic units; The TA3-03B tuner and converter, the swept converter and the basic low frequency unit (B2).

5.4.1 TA3-03B Tuner (2 - 300 KHz)

Refer to SWD-4073B, Figure 11.14. A low pass filter #5037A is used to prevent large out of band signals from entering the tuner. D1 and D2 are protective diodes to prevent burn-out of the broadband amplifier, Q1.

Q2 is an emitter follower used to match the 50 ohm input impedance of the balanced mixer, MX-1.

Q3, the local oscillator, is electrically tuned by varicaps D4 and D5 which are controlled by a ten turn pot, R10. This is the tuning control. The low end of the frequency range is determined by R9, the high end by R11 and the mid range setting by L2. The local oscillator tunes 457 to 755 KHz.

Q4 is a source follower used to match the low input impedance of the balanced mixer. The IF frequency is 455 KHz.

5.4.2 Swept Converter

Refer to drawing SWD 4033-4035C, Figure 11.13. The signal from the High Frequency Receiver enters through a low pass filter having a cutoff frequency of 26 MHz. Q3 serves as a 23.5 MHz amplifier having a bandwidth of 5 MHz.

The swept converter uses a local oscillator range of 31.7 to 36.7 MHz and can be electronically swept by varicap CR4 when used with the Visual Display Unit. The oscillator drives an IGFET (Q5) which serves as a 23.5 MHz buffer amplifier with a bandwidth of 5 MHz.

The 31.7 to 36.7 MHz local oscillator signal is mixed in Q6 with the 21 to 26 MHz signal from the 23.5 MHz amplifier, Q3, to generate a 10.7 MHz IF. This signal is used to provide information for the Visual Display Unit when operated in the panadapter mode in conjunction with the High Frequency Receiver.

The swept 10.7 MHz IF goes through a crystal filter centered on 10.7 MHz which has a bandwidth of 15 KHz. A crystal controlled local oscillator (Q2) furnishes a 10.245 MHz signal to a mixer (Q1) to obtain a 455 KHz signal

which is routed to the T-03B/converter input selection switch of the LFR.

5.4.3 Basic Low Frequency Unit (B-2)

Refer to drawing SWD 4031B, Figure 11.12.

5.4.3.1 455 KHZ Amplifier, Emitter Follower and Bandpass Filter.

The input to the B-2 may be selected with a front panel switch (T-03B converter) to be either from the TA3-03B Tuner and converter, or from the 23.5 MHz to 455 KHz swept converter. This switch also applies 18 volts to the appropriate unit to be used. The selected signal is amplified by Q1 which has AGC applied to Gate #2. Q2 is an emitter follower which provides an impedance match to one of the bandpass filters which can be selected by switch S14. Bandwidths of .2, 2 or 10 KHz are available.

5.4.3.2 455 Amplifier String, AM Detector and S Meter

Q3, Q4 and Q5 furnish three stages of 455 KHz amplification. AM detection is accomplished by CR5 and CR6. AGC voltage is tapped off at this point (TP4). The S Meter signal is also derived here. The S meter may also be used to monitor the condition of the PS-10 AC Power Supply or the BP-7 battery pack by placing a load (R35) on the voltage terminals of the power supply and observing the current drawn through the S meter.

5.4.3.3 Video Detector

The AM Video Detector consists of CR7 and CR8. This furnished video output through J22 to the Visual Display Unit.

5.4.3.4 FM Limiter and Detector

Q6 is a limiter which feeds the discriminator consisting of the T-4 network and CR11 and CR12. The output of either the FM discriminator or the AM detector is selected by S-16 and routed to the audio amplifier.

5.4.3.5 Audio Amplifier

The audio Amplifier consists of Q7 and Q8. The audio gain is controlled by R50. The audio output is available at J20 which has an output level greater than 6.5 mw and an output impedance of 1000 ohms.

5.4.3.6 455 KHz Beat Frequency Oscillator

Q9 is a 455 KHz oscillator which furnishes a beat signal. The output is tuned by T-3 and coupled to the 455 KHz amplifiers by stray radiation. The pitch of the beat note may be varied by adjusting R65 which appears on the front panel. R65 also contains a switch to turn the BFO on and off.

5.5 VISUAL DISPLAY UNIT (S-3)

Reference to drawings SWD 4038-C, Figure 11.15 and SWD 4039-C, Figure 11.16 shows the schematic diagrams for the visual Display Unit (VDU). The anode voltage of 1200 volts DC is generated by a DC to DC converter housed in a hermetically sealed metal housing. The converter also furnishes 200 volts DC to the vertical deflection plates of the CRT. Filament voltage for the CRT is taken from a third winding on the DC to DC converter.

5.5.1 Sawtooth Sweep Generator

Refer to drawing SWD 4038-C, Figure 11.15 for the schematic of the VDU sawtooth sweep generator. Q1, Q2, Q3 and Q4 make up a sawtooth generator whose frequency is determined by SW-23 with a fine frequency control R2. The output of Q4 is fed to the horizontal printed circuit board. The sweep frequency can be varied between 1 Hz and 66 KHz with these controls.

Provision is made for use of external sync. Q5 and Q6 form a sync amplifier. A minimum of 1.5 volts must be supplied from the external sync source.

5.5.2 Vertical Amplifier

Refer to drawing SWD 4038-C, Figure 11.15. The position of the display switch S17 determines whether the vertical deflection plates are used directly or receive an amplified signal through the vertical amplifier. The vertical amplifier consists of three stages (Q21, Q22 and Q23), driving a push-pull output amplifier consisting of Q24 and Q25. Gain is controlled by R21 in the base circuit of the first stage (Q21). Vertical centering on the CRT screen is accomplished by adjusting R44 on the control panel. A 6 mv peak signal is necessary for full vertical deflection.

5.5.3 Horizontal Amplifier

The horizontal amplifier receives a sawtooth voltage from the sawtooth generator shown on drawing SWD 4038-C, Figure 11.15. Sweep gain is provided by the horizontal output amplifier (Q10 and Q11). Sweep gain may be adjusted by R59 in the emitter circuit of Q10. Horizontal centering is controlled by R57 which balances the DC between the horizontal

deflection plates.

Q7, Q8 and Q9 form an isolation amplifier for the sawtooth sweep voltage. Peak amplitude of the sweep voltage is determined by the divider network associated with Switch S22-B (sweep width control).

The sweep output appears at J-27 and is used to furnish sweep voltage to the local oscillators of the low frequency and high frequency receivers for visual display purposes.

The four potentiometers (R47, R48, R49 and R50), are used to adjust the DC bias level on the sweep voltage. It is necessary to have equal average voltage for all sweep widths to provide symmetrical horizontal displays on the CRT.

5.6 POWER SUPPLY PS-10

Refer to drawing SWD 4074B, Figure 11.18 for a schematic of the PS-10. The PS-10 furnishes highly regulated 18 volts DC at 300 ma for powering all A-3B components from commercial power mains. There is no on-off switch on the PS-10.

Input voltages of $115V \pm 20V$ or $230V \pm 30V$, 50 or 60 Hertz may be selected by a panel switch. A $\frac{1}{4}$ ampere fuse is used as protection on the primary side of the transformer.

The power supply uses a full wave bridge rectifier. D2 is a Zener diode voltage regulator. Q1 and Q3 form a Darlington series regulator, integrated circuit IC-1 and Q2 form a feedback regulator. The output voltage is controlled by R4.

The power line antenna is built into the PS-10 for use when the power lines must be scanned. The BNC output connector is located on the top panel of the PS-10.

5.7 BATTERY PACK ASSEMBLY (BP-7)

Refer to drawing 30460C, Figure 11.19 for diagrammatic information. Fourteen (14) cells in series furnish 18 volts for all of the equipment in the A-3 Receiver System.

Lifetime of the batteries will vary with the type used. Minimum operating life is 25 hours with all units operating. The BP-7 will operate one receiver for over 100 hours.

CAUTION: DUE TO THE HIGH ENERGY STORAGE CAPABILITY OF MERCURY BATTERIES, CARE SHOULD BE TAKEN THAT EXPOSED TERMINALS ON THE BP-7 DO NOT CONTACT CONDUCTIVE OBJECTS.

Preferred batteries are Mallory RM12-R or equivalent. For low temperature operation, an Alkiline battery will give improved operation and dependability.

PART SIX: OPERATING PROCEDURE**6.0 Operation of Receiver Mode (Refer to fig. 10-1)****6.1 Low Frequency Receiver:**

6.1.1 Select either battery or AC power supply. Select either the interconnecting harness connected as per paragraph 6.3.2 and fig. 10.1; or the 2 connector power cable attached between AC supply or battery pack and LFR. ~~There are no power ON/OFF switches therefore the cable applies power directly.~~ If using AC power supply, set input line voltage switch to voltage range of AC line. If line voltage is unknown, set to high voltage position, hold "Battery Test" switch of receiver to "Test" position. If meter reads below red line, switch input line voltage switch to lower range. If using battery pack, hold battery test switch in "Test" position. It should read above red line. If not, replace batteries or use other battery pack. Operating time will be extended by connecting the battery packs in parallel rather than using them sequentially. To use packs in parallel, connect adjacent power plugs of interconnecting harness to the two battery packs.

6.1.2 Select antenna (with Low Frequency unit use Ferrite Antenna as marked, long wire, power line (located on power supply panel) or other accessory probe. CAUTION: POWER LINE VOLTAGES ARE DANGEROUS TO LIFE AND SOME PROBES DO NOT PROVIDE ISOLATION. Connect antenna to BNC input or tuning section. Connect phones to phone jack.

6.1.3 Control settings: Set converter/T0-3 switch to "T-03". Set no Sweep/Sweep switch to "no Sweep". Set AGC/Manual switch to "AGC". Turn BFO Control to "OFF". Set bandwidth switch to 2 KHz. Set meter Level switch to "LOW". Turn Audio Gain Control up until noise is heard in earphones. Turn tuning knob until signal desired is heard and indicates on meter. Read frequency on direct reading dial. Adjust AM/FM, Bandwidth, Low/High, AGC/Manual and IF Gain Controls as required. If desired turn BFO Control on and adjust pitch by turning clockwise or counterclockwise. Note that below an RF frequency of 15 KHz, the 10 KHz bandwidth position should not be used. If used, the bandpass response will include the local oscillator thereby overloading the IF amplifier and blocking the receiver. The same may occur if the 2 KHz position is used below 5 KHz RF. Figure 10-1 shows the power hook-up and location of controls.

6.2 Operation of high Frequency Receiver:

6.2.1 Connect cable and adjust and test power supplies with High Frequency Receiver as in Paragraph 6.1.1.

6.2.2 Select RF band to be used and adjust band switch accordingly. Frequencies covered by each band are indicated next to tuner dial window. (Note that Tuner No. 6 has two bands. Use push-pull switch on tuner panel to choose band. Antenna connector is common). Next, select antenna, Ferrite loops, long wire, power line pickup, or whip may be used effectively up to 3 MHz. (The Ferrite Loop so marked is good to 30 MHz). Above 30 MHz, the whip antenna may conveniently be used. A "bow tie" type antenna is also provided for frequencies from 600 to 1600 MHz. Extend telescoping mast and place large end in socket hole provided in battery pack top. Then mount bow tie antenna on mast with block provided. Attach BNC cable between bow tie connector and tuner to be used. Entire antenna, mast and battery pack assembly may be remotely deployed from carrying case. Since the bow tie antenna is directional, it may be necessary to rotate it for maximum signal strength. The frequency range of this antenna may be extended down to 100 MHz by fully extending the four rods provided. This does not cause the 600 to 1600 MHz performance to suffer.

6.2.3 Adjust settings of receiver in same manner as described in Paragraph 6.1.3 for the low frequency receiver except that there is no "No Sweep/Sweep" switch to set. Again, as with the low frequency receiver, the bandwidth setting must always be set to a bandwidth frequency of 1/10 or less than the RF frequencies. Therefore, do not use the 1 MHz bandwidth below an RF of 10 MHz. There is an additional switch on the High Frequency Receiver marked FM wide/narrow. The purpose of this switch is to provide a narrow, crystal type discriminator with peak separation of 90 KHz for use when the IF bandwidth switch is in the 90 or 20 KHz position. Use "Wide" FM position of switch for 1 MHz IF bandwidth. Figure 10-1 shows the power supply hook-up and location of the controls.

6.3 Panadapter Mode:

The purpose of the panadapter mode is to visually display all signals within a certain RF band, the center of which is determined by the tuner frequency setting. The sweepwidth displayed (dispersion), and the resolution of adjacent signals, are adjustable. Many important features of incoming signals may be determined and analyzed by proper adjustment of the receiver in the panadapter mode. Some of these are side band determination type of modulation, frequency spacing of signals and relative signal levels. The panadapter mode is also an aid in signal searching. The details of signal analysis will not be covered in this Manual since they are common to the trade. It will suffice here to cover the operational procedure to achieve the desired displays.

6.3.1 Theory: The panadapter mode utilizes the low frequency receiver section and the visual display unit together in what is commonly known as a "Panadapter". This panadapter is then attached to the high frequency receiver and scans or "looks at" signals appearing at the high frequency receiver IF output. The scan width or "dispersion" capability of this combination unit is 0 to 5 MHz adjustable. Therefore its maximum Sweep frequency coverage is 21 to 26 MHz (5 MHz about the high frequency receiver IF center frequency of 23.5 MHz). Following the signal through the system, the incoming antenna signal is converted by the tuner used to 23.5 MHz. At this point it branches off to the low frequency receiver converter input and the high frequency IF with its filters. The high frequency receiver unit further processes the signal to audio and meter read out as a straight receiver. All controls of the high frequency receiver are used as described in Paragraph 2.2 to 2.2.3. The local oscillator of the converter of the low frequency receiver is driven through the 5 MHz scan range by a sawtooth signal from the Visual Monitor. It therefore scans and converts to 10.7 MHz and then to 455 KHz, all signals on a time sharing basis within the 21 to 26 MHz band. These signals are then processed by the 455 KHz IF amplifier with its .2, 2 and 10 KHz filters (which now control the resolution) and detectors. The signal is then fed to the monitor and displayed as a frequency verses amplitude plot.

To conveniently use the S-3 Monitor, remove pad in case lid above monitor. Next, rest monitor with power connector down and facing out on lower edge of open attache' case lid. Align Velcro hook and eye latching tape disks found on underside of S-3 and in the lid and press firmly together. Raise mirror to convenient angle and make cable hook ups as needed. To repack S-3, close mirror, and remove by pulling top out first. Pack all accessories in large pocket and place lower pad provided on top of accessories. Then place monitor, panel up in pocket on top of lower pad and replace upper monitor pad in lid. Make sure that interconnecting harness section between S-3 and LFR is clear of case hidge as lid is closed. ALWAYS REPLACE MONITOR AND PADS FOR HAND CARRYING AND SHIPPING. DO NOT LEAVE MONITOR MOUNTED ON CASE LID.

6.3.2 Cable Hook-up (Refer to Figure 10-1):

Attach interconnecting harness as follows:

- A) S-3 POWER IN.
- B) S-3 SWEEP OUT
- C) S-3 PAN IN.
- D) S-3 SIGNAL IN.
- E) HFR DETECT OUT.
- F) HFR IF OUT. Either WIDE or 90 KHz (see instructions)
- G) HFR POWER IN.
- H) LFR POWER IN.
- P) LFR SWP IN.
- J) LFR PAN out.
- K) T03 Antenna input.

- L) LFR CONVERTER IN.
- M) PS-10 18V OUT or BP-7 18V OUT
- N) No connection or (BP-7 18 volts out if PS-10 not used)

This harness may be left connected except for battery pack connection when unit is stored with lid closed. The harness provides all connections except antenna and earphone for Receiver Mode, Panadapter Mode, T03 Tuner Scanning Mode, Double Detect Mode, and Video Mode. Remote Tuner Mode, Oscilloscope Mode, and HFR Tuner Scanning Mode require special hook ups.

Note that there are two (2) 23.5 MHz IF output jacks. The right hand output is used in bands 1, 2 and 3 limiting the dispersion to 90 KHz and eliminating spurious responses due to the tuner local oscillator being in the 21 to 26 MHz region. Use the left hand outlet for tuners 4 through 8 allowing up to 5 MHz dispersion. Select tuner and antenna as in Paragraph 6.2.2. Use ear phones on high frequency receiver only. When using the visual display unit with receivers, use both battery packs to greatly extend operating time. This is important and is required to operate panadapter system for over 25 hours. Disconnect BOTH battery packs when using AC supply and when unit is not in use.

6.3.3 Adjustments Low Frequency Receiver: Converter/T0-3 switch to "Converter". No Sweep/Sweep switch to "Sweep". Bandwidth switch to 10 KHz resolution for wide dispersion and 2 KHz or 200 Hz for narrow dispersion. Audio frequency gain off (counter clockwise). S meter level switch to "High". AM/FM switch to AM. BFO off.

6.3.4 Adjustments, High Frequency Receiver: Same as Paragraphs 6.2 to 6.2.3.

6.3.5 Adjustment Visual Display Unit: Sweep rate switch next to slowest position. Swing mirror hood to "UP" position for reflected image. Amplifier switch to PAN position. Sweep frequency vernier to speed where flicker just appears. Sweep gain control and Sweep centering control until baseline is wide enough and centered to align between outside lines at edge of screen. Sweep width control: 6 KHz per division for Bands 1, 2 and 3; and maximum for other bands. Focus and intensity for best display. The tracking of the centering of the sweep width positions is factory set however adjustments may be required from time to time as unit ages or if different LFR is used. To check alignment turn tuner select switch to 8. Use no antenna on tuner. Set sweep width switch to 500 KHz/Div (Max CCW). Turn BFO of HFR to "ON" position and LFR Bandwidth position to 2 KHz. Also place connector "F" of harness on "wide" IF output of HFR. A signal should appear on screen. If not, place extra BNC cable between "Det out" HFR and "Converter IN" of LFR and turn LFR IF gain down to show single distinct spike on screen.

Now turn sweep width control to .3 KHz/div (Max CW). Center this signal on screen by adjusting centering control of LFR. Now switch step by step counter clockwise through each Sweep Width position. The signal caused by the BFO should remain within 1/8 inch of center. If signal does not remain on center, remove plate above sweep width control and adjust trimmer with small screw driver to center signal on switch position which is off center. Maximum CCW of sweep width position is controlled by trimmer 1-C, next clockwise is controlled by trimmer 2 and so forth. If all positions heed adjustment, set centering control LFR to its mechanical center. Then proceed to center each position with trimmers in the following order 1, 6, 5, 4, 3, 2. If it is impossible to center it this see alignment instructions for S-3 and C-2 under part seven of this manual.

6.3.6 VDU Operation: As the operator tunes the signals with the tuner knob, incoming signals will be displayed on the CRT screen showing frequency position and amplitude. If magnification of certain areas is desired, tune area to screen center then back down on sweep width control. It may be required to recenter with the low frequency receiver centering control. When area of interest has been magnified, set low frequency bandwidth switch for next lower BW. This will further increase resolution and further magnification is possible. If difficulty is encountered in determining proper center at narrow dispersion so that visual signal on center is the same as that heard in phones, proceed as follows: With sweep width set at wide dispersion, turn high frequency BFO on. Back off sweep width control to narrow dispersion position. Adjust center frequency control to place this response at screen center. Now, with BFO off, tune to any RF signals. Centered visual signals should be the same as the audio output signals.

6.4 Tuner Scanning Mode:

(Refer to Figure 10-1) The purpose of the tuner scanning mode is to provide visual scanned displays of signals on the T0-3B Tuner range (2-300 KHz) not available in panadapter mode and to provide visual scanned displays of the high frequency receiver without use of low frequency unit.

6.4.1 Cable Hook-up Low Frequency Receiver is provided by the inter-connecting harness (Refer to Figure 10-1).

6.4.2 Control Settings, LFR Tuner Scanning Mode: Set converter/T03 Switch to "T-03". Set No Sweep/Sweep switch to "Sweep". Set AGC/Manual switch to "AGC". Set BFO control to "OFF". Set Bandwidth switch to "2 KHz". Set meter Level switch to "HIGH". Set Audio Gain Control to Minimum. Set Visual Display Unit as in Paragraph 6.3.5 except set sweep width control to Maximum.

6.4.3 Operation of LFR Tuner Scanning Mode: Turn tuning knob through band to search. Signals will appear on screen as they are received. Maximum sweep width in this band (2-300 KHz) is 250 KHz. T0-3B Tuner Sweep widths are listed at the sweep width control of the S-3. Note that if the T0-3 tuned frequency is less than $\frac{1}{2}$ the total sweep width the S-3 scan will include the IF response. To set the display for zero frequency on the left side of the screen, remove T0-3 antenna connection, set sweep width as desired and tune T-03 so that IF response (spike on base line) just shows on left end of base line. When using 200 Hz position, use very slow sweep speed for best resolution. Magnification of desired area of spectrum is accomplished as in Paragraph 6.3.6. It should be noted that in the "Tuner Scanning Mode" audio output cannot be used since the tuner local oscillator is being scanned through a range of frequencies thereby producing audio output of signals on a time sharing basis making them unintelligible. If audio output is desired, tune signal in by scanning and centering on screen, then switch to "NO Sweep" position. Signal tuned in should now be heard on phones. If not perfectly centered, retune control slightly. Besides being an aid in searching and analyzing signals, the tuner scanning mode can be used in alignment of the receiver IF amplifiers and AM and FM detectors since the curves presented are frequency verses amplitude plots of the amplifier/detector response curves. The alignment procedure will be covered in the Alignment Section.

6.4.4 Cable Hook-up of High Frequency Receiver: Use interconnecting harness as per paragraph 6.3.2 and Figure 10-1 except disconnect BNC "B" and connect spare one foot BNC Cable from S-3 "Sweep Out" and HFR "SWP. IN".

6.4.5 Control Settings, HFR Tuner Scanning Mode: Set controls as Paragraph 6.2.2 and 6.2.3 "Receiver Mode" and set visual display unit as per Paragraph 6.3.5 except AMP/PAN Switch to "AMP". As in the panadapter mode, care must be used in selection of sweep width and bandwidth. The "Sig Gain" Control will adjust the signal gain of the S-3. Again, as with the low frequency receiver, the audio output will be unintelligible unless sweep is minimum or removed. This is accomplished by rotating sweep width control to minimum or disconnecting sweep cable. Also, as in the low frequency receiver tuner scanning mode, this mode may be used for receiver alignment. An advantage of using the high frequency receiver tuner scanning mode over the panadapter mode is that the bandwidths of 20, 90 and 1000 KHz are available which show up better as a larger percentage of the scanned frequency on the visual monitor. The markings on the Sweep Width Control on the visual monitor do not apply to the tuner scanning mode. Also, non-linearities may occur in frequency verses displacement in this mode.

6.5 Double Detect Mode:

(Refer to fig. 10-1) The purpose of this mode is to detect the modulation existing on a sub-carrier of a radio signal.

6.5.1 Such a signal is produced by modulating the main carrier frequency with a fixed frequency usually above the audio spectrum. The type of modulation producing this sub-carrier may be AM, FM or other. The sub-carrier will appear as fixed side bands on the visual display unit, either in the panadapter or tuner scanning modes. They appear as equally spaced pips, one on each side of the carrier and lower in level than the carrier dependent on the percent modulation. Some transmitting systems use suppressed carrier or single side bands in which case only one pip will appear next to the carrier.

Resolutions as low as 2 KHz may be necessary to resolve the side bands as they may be very close (5 KHz) to the main carrier. Normal single demodulation, when centered on the main carrier, will provide at the detected output the sub-carrier with its modulation still undetected. Also at this point will be the detected modulation of the main carrier. The sub-carrier will be present only if the bandwidth of the receiver and detector is wide enough to accept the displacement of the sub-carrier. For instance, a carrier having a 100 KHz sub-carrier produces upper and lower sidebands 200 KHz apart. A receiver bandwidth of 200 KHz and detector bandwidth of 100 KHz is necessary to extract the energy in both side bands. The sub-carrier modulation is then detected by using a second receiver tuned to the sub-carrier frequency. The input of the second receiver is connected to the detected output of the first receiver.

6.5.2 Cable Hook-up, Double Detect Mode is provided by the interconnecting harness (Figure 10-1).

6.5.3 Control Setting: Set high frequency receiver controls as in "Receiver Mode" (Paragraph 6.2.2 and 6.2.3). The high frequency receiver bandwidth must be set wide enough to encompass the side bands desired. Use 1 MHz position if possible. Set low frequency receiver controls as in "Receiver Mode" (Paragraph 6.1.2 and 6.1.3).

6.5.4 Operation of Double Detect Mode: First, tune in signal having sub-carrier on high frequency receiver. (Such signals may be determined first by using the panadapter mode or the tuner scanning mode and observing side band carriers on display screen. After tuning the signal for the best audio output and highest "S" meter reading of high frequency receiver, then tune low frequency receiver through entire range for best low frequency "S" meter reading. Once sub-carrier is received on low frequency receiver, try all combinations of AM/FM detection on both high and low frequency receivers for best audio output of low frequency receiver. (Sub-carrier may be an FM modulation of the main carrier. This sub-carrier may then be AM modulated. The types of modulation used may be determined by observing the display in the panadapter or tuner scanning mode). The visual display unit may be used in the double detect mode as a searching aid to locate the sub-carrier existing once the main signal has been tuned in by the high frequency receiver. Proceed as in the "Tuner Scanning Mode Low Frequency Receiver" Paragraphs 6.4.1

to 6.4.3). Once sub-carrier is located, switch No Sweep/Sweep switch back to "No Sweep" to monitor modulation by earphones. A convenient method of spectrum scanning and modulation analyzing is to connect and set controls of system for panadapter mode as per Paragraph 6.3. Also set and adjust T03 tuner scanning mode for 0 to 200 KHz display. Place T03/converter switch of low frequency receiver to converter position and tune high frequency receiver tuner as per panadapter mode. When side bands or other modulation appears on screen center signal on screen and switch T03/converter switch of low frequency receiver to T03. Modulation components from 0 to 200 KHz will then be displayed.

6.6 Video Mode:

(Refer to Figure 10-1). In the video mode, the detected output of the receiver is displayed on the visual monitor in an amplitude verses time base display. Also, undetected IF signals of low frequency receiver (455 KHz) may be displayed.

6.6.1 Cable Hook-up Video Mode is provided by the interconnecting harness (Figure 10-1).

6.6.2 Control Setting: Set receiver controls as in "Receiver Mode" (Section 6.1 or 6.2). Set visual monitor controls as follows:

Sweep Rate Switch: To time base desired.

Sweep Rate Vernier Control: To time base desired.

Synchronizing Control: Adjust to synchronizing signal.

Sweep Gain Control: Set for base line width to end marks on gradicule.

Sweep Width Control: Not used.

Sweep Center Control: Center base line.

Signal Gain Control: Adjust to desired "OnScreen" amplitude of signal.

Amplifier/Pan switch to Amp. for HFR use, and Pan for LFR use.

Signal Center Control: Center base line in vertical direction.

Intensity and Focus Control: For best display.

6.6.3 Operation: Tune signal in as in "Receiver Mode" (Section 2.1 and 2.2). Observe detected output on visual display unit. Adjust time base controls and synchronizing control for desired display. Audio output may be used simultaneously.

6.7 Remote Tuner Operation: The purpose of the remote tuner operation is to allow the tuner and its antenna to be physically placed for best signal reception in such a manner that would be impossible or inconvenient while mounted in the receiver. Also, remote tuner operation allows servicing, alignment and test of tuners.

6.7.1 To remove the tuner, first remove the 4-40 binder head panel screws located on the perimeter of the tuner sub panel. There may be two, three or four screws depending on which tuner is being removed. Do not remove the two binder head screws near the dial window or the knob. Connect a BNC terminated cable to the antenna connector and using this as a handle, pull tuner straight out. Side to side and back to front movement may be necessary to help tuner bottom connector release. CAUTION: Handle tuner with care when out of receiver as some wiring and the gear and dial mechanism are exposed. Special care should be exercised to avoid touching the dial or dial spools. Connect remote cable connector with handle to socket at bottom of opening left in receiver. Connect other end of cable to plug at bottom of tuner. Follow color dot for proper indexing of cable connectors to receiver frame and tuner. Now proceed with any of the operational modes described in this Manual.

6.8 Oscilloscope Mode:

The purpose of the "oscilloscope mode" is to utilize the features of the visual display unit for utility oscilloscope functions such as field repair of electronic equipment, monitoring of signal wave shapes, rough frequency measurements, special visual displays such as video signals, and any other utility oscilloscope use. It is especially useful where portability and battery operations are imperative. Check specifications under Part Four, Paragraph 4.4, 4.5, 4.7, 4.8, 4.13, 4.14 and 4.16 for oscilloscope mode specifications.

6.8.1 Power Connection: Attach power cable between monitor and either the PS-10 power supply or the BP-7 battery pack. To check conditions of battery or line voltage, connect branch of power cable to either low or high frequency receiver and proceed as per Paragraph 6.1.1. The receiver may then be

detached and the power supply or battery pack and the monitor used as a complete oscilloscope.

6.8.2 Vertical Amp. Operation: Set Sweep Rate Switch to the approximate repetition rate of signal to be displayed. Set synchronizing Internal/External switch to internal unless horizontal sweep rate is to be controlled by external signal in which case feed synchronizing signal to external synchronizing jack and switch the internal/external switch to external. Attach input signal cable to input jack. Note that monitor does not have signal attenuators except for the gain control. However, 50 ohm BNC/BNC calibrated attenuators found in the A-3 accessories may be used. Set Sweep Gain, Sweep Centering, Intensity, Focus, and Signal Center controls for best display. Advance signal gain control for desired vertical display height. With synchronizing control at minimum, set sweep rate so that the pattern is as steady as possible. Then advance synchronizing control until signal locks on. Synchronizing control operates level of either internal or external synchronizing dependent on the synchronize switch position.

6.8.3 TV Display Operation: Set Sweep Rate, Sweep Vernier, Synchronizing Switch and Synchronizing Control as in Paragraph 6.8.2 for external synchronizing of horizontal signal. Attach vertical signal to signal input jack and set Amp/Pan switch and signal gain control for vertical signal deflection. Video signal is fed to the Z axis jack. Adjustments are then made as follows: Sweep Rate and Synchronizing Control for "Horizontal Hold". Signal Gain, Signal Centering, Sweep Gain and Sweep Center for proper picture centering and proportion. Intensity for proper "brightness" and full cut off so that the unbiased AC video signal will swing beam current towards cutoff and maximum without distortion. Z axis signal level, controlled by external equipment sets "contrast". Vertical sweep rate and synchronizing controlled by external equipment sets "vertical hold".

It is possible to use the A-3 high frequency receiver as the signal receiver for television type signals, the output appearing at the detected output jack. Video information may be limited by the one MHz maximum bandwidth of the receiver. Five (5) MHz bandwidth may be taken at low level at the IF output jack. However, this signal must be further amplified and detected. For video display, external equipment must also have a vertical sweep generator, synchronizing, vertical hold and video amplification. An attachment for this purpose (TV-1) is available.

PART SEVEN: REPAIR AND ALIGNMENT OF COMPONENT PARTS**7.1 SCOPE**

Due to the extreme complexity, miniature size and frequency range of the A3 Receiving System, repairs should be limited to those persons who are familiar with equipment of this type. Except for emergency cases, it will consume less time to return the system and/or component to F. G. Mason Engineering for repair or replacement. Special care must be taken in examining any of the tuners as placement of components and routing of wiring will affect the performance. **THIS IS IMPORTANT!**

To remove the tuner, first remove the 4-40 binder head panel screws located on the perimeter of the tuner sub panel. There may be two, three or four screws depending on which tuner is being removed. Do not remove the two binder head screws near the dial window or the knob. Connect a BNC terminated cable to the antenna connector and using this as a handle, pull tuner straight out, side to side and back to front movement may be necessary to help tuner bottom connector release. **CAUTION:** Handle tuner with care when out of receiver as some wiring and the gear and dial mechanism are exposed. Special care should be exercised to avoid touching the dial or dial spools. Connect remote cable connector with handle to socket at bottom of opening left in receiver. Connect other end of cable to plug at bottom of tuner.

B-1 ALIGNMENT

1. The B-1 section of the High Frequency Receiver includes those portions from the Bandswitch output through the audio and video outputs. Refer to SWD 4048D for the circuit schematic. Remove the B1/C1 from the main chassis by removing all screws from the bottom plate. This will expose the 4 wire cable and 3 coax cables connected to the B1/C1. Carefully remove these. Remove the 4 screws at the edge of the B1/C1 front panel face. The B1/C1 may now be pulled from the main frame through the top. Remove the 4 binder head screws which fasten the top plate to the B1. Remove this plate to expose the alignment coils.
2. With all transistors in their sockets, and battery test shows normal, check voltage at points C18, C19, C20, C21, C22. This should be + 18 volts.
3. If voltages are corrects, set controls as follows:

IF Gain	Full CW
AGC-Man	Man
AM-FM	AM
FM-Nar. Wide	Wide
BFO	Off
AF Gain	Full CW
Meter Hi-Lo	Lo
Bandwidth	1 MHz

Place plug in "Audio Out" jack. Connect audio "Out" to "Y" input on oscilloscope, shunt with 1 K resistor. Also, connect VTVM across audio "out".

Apply a 23.5 MHz signal to J11. (IF OUT-WIDE)

Remove Q1

Apply power to receiver at jack J15 (POWER IN)

4. Noise should not appear on the oscilloscope. Using a high level signal and tuning through 23.5 MHz, 1000 Hz modulation, a 1000 Hz signal should appear on the scope. At this point tune each coil slug for maximum signal, lowering the input signal as you tune the slug to 23.5 MHz. Switch to FM, increase signal input and adjust the FM coil slugs of T6 and T7 for maximum response. Switch to AM.
5. With signal on scope in AM Mode, turn BFO switch to "on". Tune signal generator through 23.5 MHz - there should be a beat note at 23.5 MHz if the BFO is working. This "beat" may be used as a marker later in the alignment procedure. Switch BFO to "off". With signal on scope, test AF gain control for operation. Then test manual gain control for operation. "S" meter should operate with change in manual gain. Test meter "Hi-Lo" switch. When "S" meter reads full scale in "Lo", the "Hi" position should be approximately 20.

B-1 ALIGNMENT

6. At this time, it is safe to assume that most of the B-1 circuits are functional. Apply power. Switch and controls should be the same as Step #3. Because the IF coils are tuned to peak at 23.5 MHz, the system may have too much gain and tend to oscillate. The "S" meter will peg if the B1 oscillates. Turn down the manual gain control. Load the input with a 50 pad. This should allow you to read the "S" meter. You are ready for stagger tuning.
7. This step requires the following equipment:
Sweep Generator Eico (369)
Oscilloscope

Connect sweep "Demod In" to detect out J14 (see drawing SWD 4048D).

Connect "RF Out" cable to J11, use 50 ohm pad.

Connect scope cable to scope. Switch scope to "Ext-Horz".

Tune marker to 23.5 MHz.

Tune sweep to 23.5 MHz.

Set RF level to "High".

Apply power to B-1.

Adjust controls on sweep generator and scope until you get a picture of the IF response of the B-1. Adjust T1, T2, T3, T4, and T5 until you have the following picture:

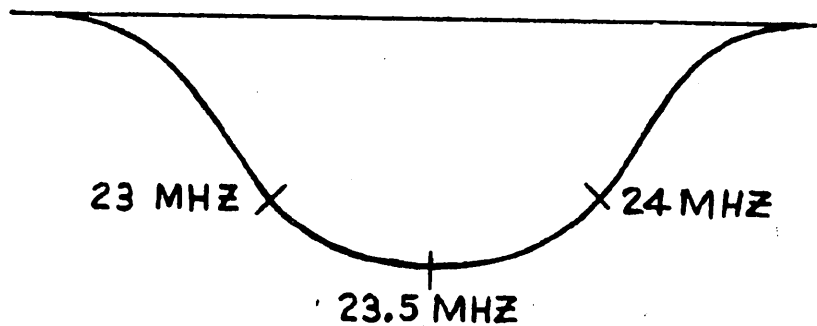

Adjust system until you achieve 1 MHz bandwidth at 6 dB points on response curve. This is done by stagger tuning, ie, T1 is tuned a little below 23.5, T2 is tuned a little above 23.5 etc., so that the net result is as pictured. The marker may be checked by switching to BFO - the BFO should superimpose the marker if the marker is correct. The BFO is crystal controlled.

Switch AM-FM switch to FM, Nar-Wide to Wide. Remove Q5, inject signal from sweep generator through a .01 capacitor into pin 1 of Q5 socket.

Adjust T6 for maximum amplitude, then adjust T7 for FM crossover. You should get a presentation as below:

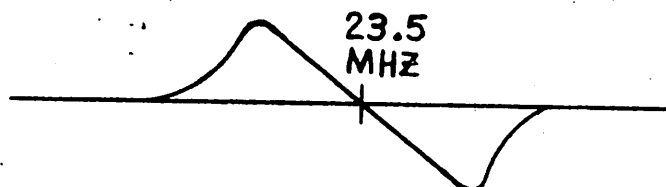

B-1 ALIGNMENT

The FM Nar. position has no adjustment. It is a crystal discriminator. Switch back to AM mode; remove sweep generator connections; turn off sweep. Set switches and controls as indicated in Step #3. Inject signal of 23.5 MHz at 10 uv into J11. The "S" meter should read full scale in the 1 MHz position for 8-10 uv. Tune through 23.5 MHz to check bandwidth.

8. Crystal Filter Check: Turn bandwidth to 2 KHz position. Tune signal generator for maximum reading on "S" meter. Switch through all positions of the bandwidth switch. "S" meter readings should remain between 6 and full scale.

C-1 ALIGNMENT PROCEDURE

1. The C-1 is the 111 MHz to 23.5 MHz converter located on the chassis of the A3 High Frequency Receiver. Refer to SWD 4048D for the schematic diagram. Remove the HFR from the main chassis by removing all the screws from the bottom plate. This will expose the 4 wire cable and 3 coax cables connected to the HFR. Carefully remove these. Remove the 4 screws at the edge of the HFR front panel face. The HFR may now be pulled from the main frame through the top. Remove the 17 binder head screws which hold the bottom plate of the HFR. Remove the bottom plate.

2. Connect equipment as shown in block diagram below:

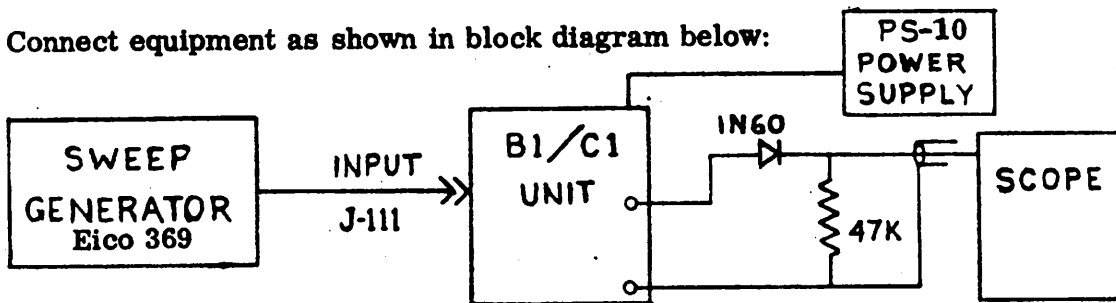

Connect diode detector shown above by referring to drawing PWD 30106X sheet 2 and performing the following steps:

- (A) Disconnect wire from coil L-12 center tap at balanced mixer.
 - (B) Connect diode to lead disconnected from coil L12. Connect 47K resistor to ground terminal on balanced mixer.
 - (C) Connect shielded cable from diode to scope.
3. Connect a jumper between pin A and Pin D on J113.
 4. Tune sweep generator to 111 MHz with output attenuator set for maximum output. Set sweep width on 10 MHz.
 5. Adjust transformers L8, L11, L9, and L12 until the following waveform is obtained:

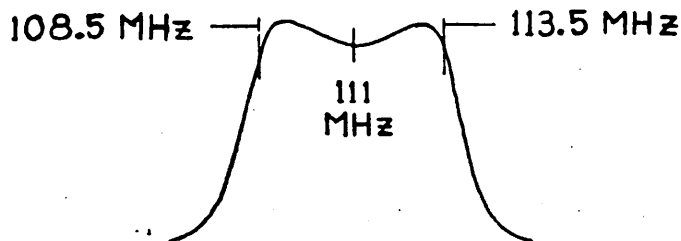

Adjust L6 for maximum amplitude. It will be necessary to reduce sweep generator output level as these adjustments are made.

C-1 ALIGNMENT PROCEDURE

6. This completes alignment. Remove diode and 47K resistor and reconnect coil lead to balanced mixer. Replace rear cover. Remove jumper from J113. Return B1/C1 chassis to case.

TA3-1 ALIGNMENT PROCEDURE

1. Remove the TA3-1 tuner from the HFR chassis by removing the screws at the edge of the tuner face.
2. Connect as shown below:

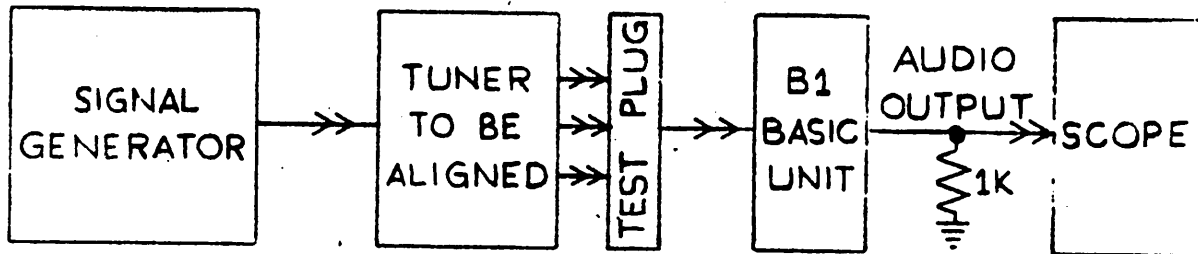

Refer to drawings PWD 4023C and 30116B and SWD 4023B for the location of test points and components. Use the B1 in the 20 KHz bandwidth position. Adjust the bandsread control for mid-range.

3. Turn tuner knob to maximum CCW.
4. Tune signal generator to 300 KHz with 100 microvolt output and apply power to the system. Use 1000 Hz, 30 per cent modulation.
5. Adjust the oscillator transformer T3 for maximum output on scope.
6. Turn tuner knob to maximum CW and tune signal generator to 1.1 MHz.
7. Adjust trimmer on C26 for maximum output. Repeat steps 3 through 7 to be certain the frequencies are still correct.
8. Turn tuner knob maximum CCW and signal generator to 300 KHz.
9. Adjust cores in T1 and T2 for maximum output on scope.
10. Rotate tuning knob maximum clockwise and signal generator to 1.1 MHz.
11. Adjust C18 and C19 for maximum output.
12. Rotate tuning knob 3 turns clockwise from extreme counterclockwise position and tune signal generator to 400 KHz.
13. Adjust T3 oscillator transformer for maximum output and retune signal generator until best signal to noise is obtained. Note frequency.
14. Rotate tuning knob to extreme CCW position and tune signal generator to 300 KHz.

TA3-1 ALIGNMENT PROCEDURE

15. Adjust C21 for maximum output.
16. Rotate tuning knob to extreme CW position and tune signal generator to 1.1 MHz.
17. Adjust trimmer on C-26 for maximum output.
18. Rotate tuning knob to frequency noted in step 13 and tune signal for maximum output. If frequency is not the frequency noted in Step 13, retune T3 oscillator transformer until frequency is correct.
19. Repeat steps 13 through 18.
20. Put "Q" dope on all adjustments.
21. Test bandsread and sweep. (Use S3 monitor).
22. Check low mid and high points in band for sensitivity and image rejection. Sensitivity at $S+N/N = 10$ dB should be better than 1.5 microvolts. Image rejection should be 80 dB minimum.

TA3-2 ALIGNMENT PROCEDURE

1. Remove the TA3-2 tuner from the HFR chassis by removing the screws at the edge of the tuner face.
2. Connect as shown below:

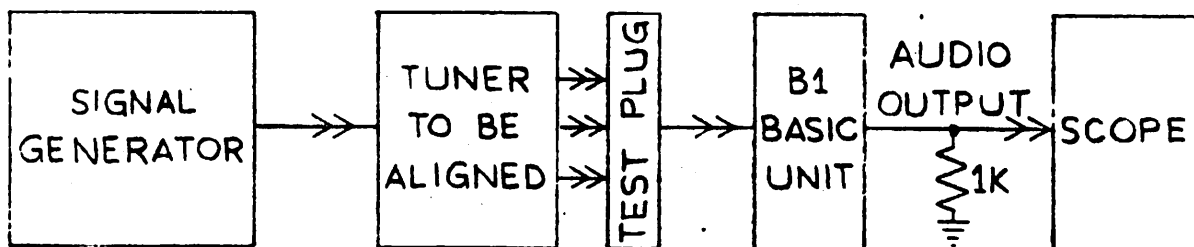

Refer to drawings PWD-4024-C, 30117-B and SWD 4024-C for location of test points and components.

Use B1 in 20 KHz bandwidth position.

Bandsread adjusted for center of range.

3. Turn tuner knob to maximum counterclockwise.
4. Tune signal generator to 1 MHz with 10 microvolt output and apply power to the system.
5. Adjust L5 oscillator coil for maximum output on scope.
6. Turn tuner knob maximum clockwise and tune signal generator to 3.6 MHz.
7. Adjust trimmer on C26 for maximum output. Repeat steps 3 through 7 to be certain the frequencies are still correct.
8. Turn tuner knob maximum counterclockwise and signal generator to 1 MHz.
9. Adjust cores in T1 and T2 for maximum output on scope.
10. Rotate tuning knob maximum clockwise and signal generator to 3.6 MHz.
11. Adjust C18 and C19 for maximum output.
12. Rotate tuning knob 6 turns clockwise from extreme counterclockwise position and tune signal generator to 2 MHz (mid point).
13. Adjust L5 oscillator coil for maximum output and retune signal generator until best signal to noise is obtained. Note frequency.
14. Rotate tuning knob to extreme CCW position and tune signal generator to 1 MHz.
15. Adjust C21 for maximum output.
16. Rotate tuning knob to extreme CW position and tune signal generator to 3.6 MHz.

TA3-2 ALIGNMENT PROCEDURE

17. Adjust trimmer on C-26 for maximum output.
18. Rotate tuning knob to frequency noted in Step 13 and tune signal for maximum output. If frequency is not the frequency noted in Step 13, retune L5 oscillator coil until frequency is correct.
19. Repeat steps 13 through 18.
20. Tune tuner and signal to approximately center of tuning range and adjust T3-IF coil for maximum output.
21. Put bees wax or "Q" dope on all adjustments.
22. Test bandsread and sweep. (Use S3 monitor).
23. Check low, mid and high points in band for sensitivity and image rejection. Sensitivity at $S+N/N = 10$ dB should be better than 1.5 microvolts. Image rejection should be 80 dB minimum.

TA3-3 ALIGNMENT PROCEDURE

1. Remove the TA3-3 tuner from the HFR chassis by removing the screws at the edge of the tuner face.
2. Connect as shown below:

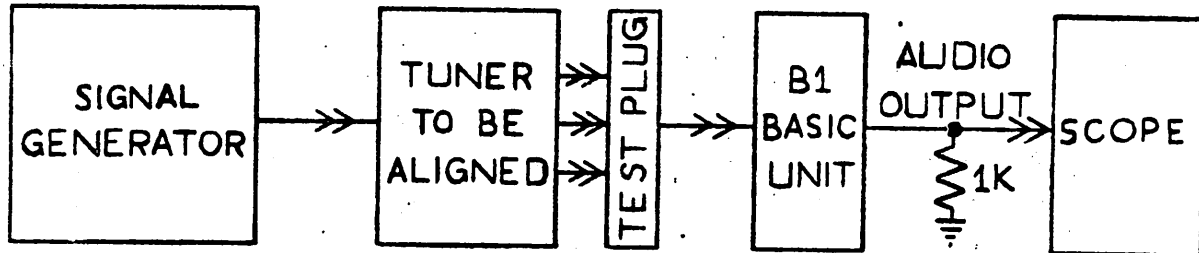

Refer to drawings PWD-4025-C, 30118-B and SWD-4025-C for location of test points and components.

Use B1 in 20 KHz bandwidth position.

Adjust bandsread for center of range.

3. Turn tuner knob to maximum counterclockwise.
4. Tune signal generator to 3.5 MHz with 10 microvolt output and apply power to the system.
5. Adjust L5 oscillator coil for maximum output on scope.
6. Turn tuner knob maximum clockwise and tune signal generator to 12.1 MHz.
7. Adjust trimmer on C27 for maximum output. Repeat steps 3 through 7 to be certain the frequencies are still correct.
8. Turn tuner knob maximum counterclockwise and signal generator to 3.5 MHz.
9. Adjust cores in T1 and T2 for maximum output on scope.
10. Rotate tuning knob maximum clockwise and signal generator to 12.1 MHz.
11. Adjust C18 and C19 for maximum output.
12. Rotate tuning knob 6 turns clockwise from extreme counterclockwise position and tune signal generator to 6.25 MHz.
13. Adjust L5 oscillator coil for maximum output and retune signal generator until best signal to noise is obtained. Note frequency.
14. Rotate tuning knob to extreme CCW position and tune signal generator to 3.5 MHz.
15. Adjust C21 for maximum output.

TA3-3 ALIGNMENT PROCEDURE

16. Rotate tuning knob to extreme CW position and tune signal generator to 12.1 MHz.
17. Adjust trimmer on C27 for maximum output.
18. Rotate tuning knob to frequency noted in Step 13 and tune signal for maximum output. If frequency is not the frequency noted in Step 13, retune L5 oscillator coil until frequency is correct.
19. Repeat steps 13 through 18.
20. Tune tuner and signal to approximately center of tuning range and adjust T3-IF coil for maximum output. Tune signal generator to 23.5 MHz, high output level. Adjust coil L7 for minimum output.
21. Put bees wax or "Q" dope on all adjustments.
22. Test bandsread and sweep. (Use S3 monitor).
23. Check low, mid and high points in band for sensitivity and image rejection. Sensitivity at $S+N/N = 10$ dB should be better than 2 microvolts. Image rejection should be 80 dB minimum.

TA3-4 ALIGNMENT PROCEDURE

1. Remove the TA3-4 tuner from the HFR chassis by removing the pan head screws at the edge of the tuner face.
2. Connect as shown below:

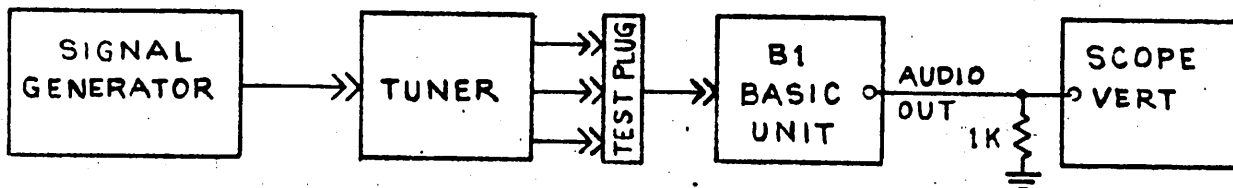

Refer to drawings PWD 4026C, 30119B and SWD 4026B for location of test points and components.

3. Remove cover from RF assembly.
4. Rotate tuner knob to maximum counterclockwise position and adjust signal generator frequency to 11.7 MHz and output level to approximately 20 microvolts.
5. Adjust core in coil T3. Then adjust cores in coils T1 and T2 for maximum output on oscilloscope.
6. Turn tuner knob to maximum clockwise position and adjust signal generator frequency to 44 MHz.
7. Adjust trimmer capacitors C26, C18 and C19 for maximum output.
8. Turn tuning knob exactly 5 turns.
9. Adjust signal generator frequency to 20 MHz and adjust core in T3 for maximum output.
10. Rotate tuner knob to maximum counterclockwise position and adjust signal generator frequency to 11.7 MHz.
11. Adjust capacitor C21 for maximum output.
12. Rotate tuner knob to maximum clockwise position and adjust signal generator frequency to 44 MHz.
13. Adjust capacitor C26A for maximum output.
14. Repeat steps 8 thru 13 until sensitivity is 1.5 uv for $\frac{S + N}{N} = 10$ dB.

N

15. Tune tuner to approximately the center of the tuning range and adjust signal generator frequency to 111 MHz with high level output.
16. Replace cover on RF assembly.
17. Adjust coil L7 for minimum output.
18. Measure image rejection at a few points in the band. It should be as follows:
RF Frequency of 12 to 20 MHz, image rejection 80 dB
RF Frequency of 20 to 43 MHz, image rejection 50 dB
19. Measure IF rejection in approximately the center of the tuning range. Rejection should be 80 dB.

TA3-5 ALIGNMENT PROCEDURE

1. Remove the TA3-5 tuner from the HFR chassis by removing the screws at the edge of the tuner face.

2. Connect as shown:

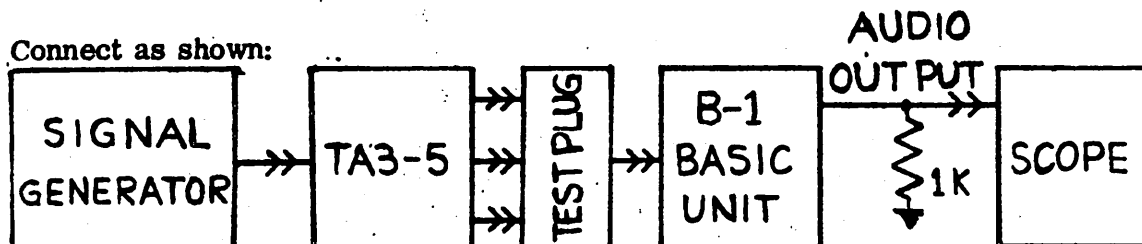

Refer to drawings PWD-30133-B, SWD-4027-B, PWD-4027-C and 30130-C for location of adjustments and components. Use B-1 in 90 KHz bandwidth, AM, Manual, and IF gain full clockwise. Adjust bandsread control to center. Track tuner with covers installed and tuner powered by remote cable.

3. Turn tuner knob to maximum CCW position. (Low end)
4. Tune signal generator to 41.5 MHz with 100 uv output (30% modulation 1000 Hz) and apply power to system.
5. Adjust L-1. Turn spacing and core to 41.5 MHz or to match the dial. Cement L-1 coil, L-1 & T-1 core & Q-1 & Q-2.
6. Tune tuner & Generator to 46 MHz.
7. Adjust T-2, L-5, L-4 & L-3 for maximum output.
8. Tune Tuner to maximum clockwise position (High End).
9. Adjust oscillator trimmers C-3-A and C-3-D so RF frequency will be 137 MHz or match the dial.
10. Tune tuner and generator to 110 MHz.
11. Adjust C16-A, C-16-D, C17-A and C17-D for maximum output.
12. Retune generator and tuner to low end and recheck sensitivity (1.5 uv for 10 dB S+N or less) at 43, 60, 80 and 130 MHz. (NOTE: Some compromise between the tracking adjustment frequencies of 46 & 130 MHz may be necessary).
13. Check the operation of the tuner in the swept mode & check operation of bandsread control. Image and IF rejection should be checked at 43, 60 and 130 MHz. It must be better than 50 dB.
14. Secure screws for T-2, L-5, L-4 and L-3 with a dot of paint.

TA3-6 ALIGNMENT PROCEDURE

NOTE: IT IS STRONGLY RECOMMENDED THAT THE ALIGNMENT OF THIS TUNER BE CONDUCTED BY THE MANUFACTURER AT HIS FACILITY SINCE SEALED COVERS MUST BE REMOVED AND SPECIAL TOOLS AND TECHNIQUES APPLIED.

1. Remove the TA3-6 tuner from the HFR chassis by removing the screws at the edge of the tuner face.
2. Connect tuner, receiver, and test equipment as shown below:

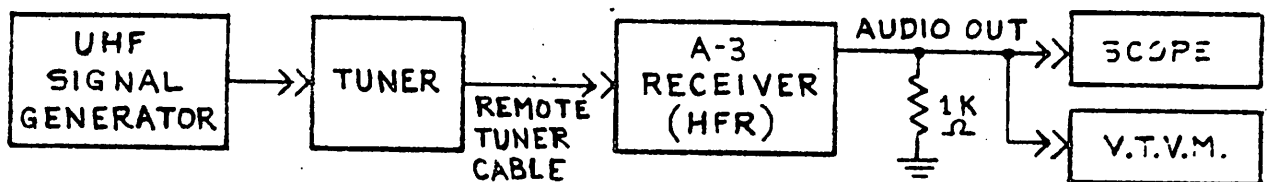

Refer to drawings SWD 4028-C and 30135-D for location of adjustments and components. Place the controls of the High Frequency Receiver in the side IF bandwidth (1 MHz), AM, Manual IF gain max, and adjust the audio gain for convenient readout on scope (some receiver noise should be seen on the scope). Use the remote tuner cable to allow accessibility to the tuner tracking adjustments. Covers, designated on the tuner assembly drawing 30135-D as numbers 78 and 79, must be removed for alignment. To remove soldered covers, start at corner, melting solder with iron while prying cover up with screwdriver or knife. Continue to run around cover in the same manner, until cover is removed. These covers are usually damaged by removal and should be replaced with new ones when remounted.

3. ALIGNMENT OF BAND 6A (130-230 MHz)
 - 3.1 Adjust L-1 for minimum output with 111 MHz input.
 - 3.2 Turn tuning knob to maximum counterclockwise position. Set bandswitch to 130-230 MHz.
 - 3.3 Set signal generator for 500 uv level and 1000 Hz AM modulation 30% and search for receiver output response.
 - 3.4 Adjust the spacing of the turns of L7 (oscillator portion of bottom section) until response frequency is between 128 and 130 MHz or matches dial if dial has been calibrated. Use needle nose pliers or small screwdriver to perform the adjustments being careful not to break the stator from the ceramic support.
 - 3.5 Adjust L8 and L9 in the same manner for maximum output response.

- 3.6 Rotate tuning knob to the maximum clockwise position.
 - 3.7 At high signal generator level search for response about the 220-270 MHz area.
 - 3.8 Bend the capacity tab associated with the C18 tuning capacitor (located below and perpendicular to the C18 stator) until the response frequency occurs between 235-245 MHz or matches the dial if the dial has been calibrated.
 - 3.9 Bend the corresponding tabs of C19 and C20 for maximum output.
 - 3.10 Rotate tuning knob CCW until first (smallest) segment of adjustable rotor blades are meshed with the stator.
 - 3.11 Find the RF location by searching downward with the signal generator at high level. It should be between 215 and 235.
 - 3.12 With the signal generator frequency set at the tuner RF frequency, adjust the first segments on capacitors C19 and C20 only as required for maximum output. If the segments have to be adjusted inwardly, adjust each side evenly so that segments do not approach stator too closely.
 - 3.13 Repeat steps 3.10, 3.11 and 3.12 for each blade segment. Note that the higher frequency segments affect the positions of the lower frequency segments, but the reverse is not true due to the meshing sequence. It is imperative, therefore, to start at the top frequency and work down.
4. ALIGNMENT OF BAND 6B (230-420 MHz)
- 4.1 Turn tuning knob to the maximum CCW position. Set tuner bandswitch to the 230-420 MHz position.
 - 4.2 Repeat steps 3.3 to 3.5 only this time set L4, L5, and L6 for maximum output at a frequency between 228 and 230 MHz.
 - 4.3 Repeat steps 3.6 to 3.13 only this time set tabs of C15, C16, and C17 for maximum output at 420 to 430 MHz.
5. Place re-tinned cover seals marked 78 upper and 78 lower on Drawing No. 30135-D on tuner as shown, and solder in place. These covers must be completely solder-sealed to the edges of the tuner walls and the internal dividers to assure oscillator radiation suppression requirements.
6. Starting at the high frequency end of the bands, retrim blade segments of each band if necessary to compensate for cover capacity.
7. Solder final covers number 79 upper and 79 lower in place.

8. **Recheck sensitivity of both bands according to instructions of paragraph 8.2 of the Receiver Testing Section.**

TA3-7 ALIGNMENT PROCEDURE

NOTE: IT IS STRONGLY RECOMMENDED THAT THE ALIGNMENT OF THIS TUNER BE CONDUCTED BY THE MANUFACTURER AT HIS FACILITY SINCE SEALED COVERS MUST BE REMOVED AND SPECIAL TOOLS AND TECHNIQUES APPLIED.

1. Remove the TA3-7 tuner from the HFR chassis by removing the screws at the edge of the tuner face.
2. Connect tuner, receiver and test equipment as shown below:

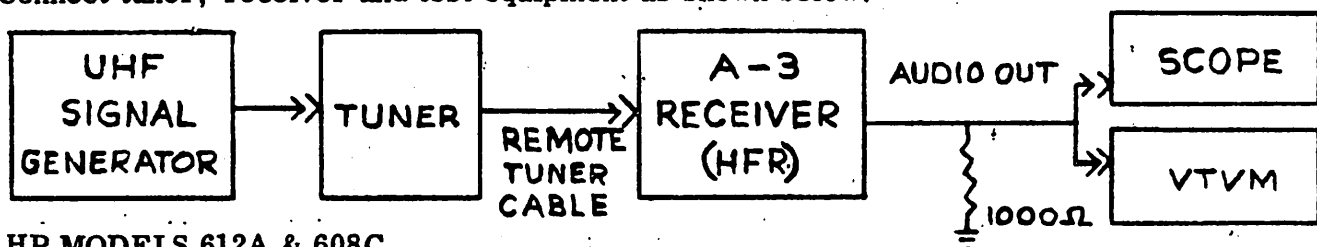

HP MODELS 612A & 608C
OR EQUIVALENT

Refer to drawings SWD 4046-C, 30140-D, and PWD 4029-B for location of adjustments and components. Position the controls of the High Frequency Receiver in the wide IF bandwidth position (1 MHz), AM, Manual IF gain Max, and adjust the audio gain for convenient readout level on scope. (Some receiver noise should be seen on the scope.) Use remote tuner cable to allow accessibility to the tuner tracking adjustments. Cover, designated on the tuner assembly drawing 30140-D with numbers 25, 26, 27, and 28, must be removed for alignment. To remove soldered covers, start at the corner, melting solder with iron while prying up cover with screwdriver or knife. Continue around the cover in the same manner until cover is removed. These covers are usually damaged when removed and should be replaced with new ones.

3. Turn tuning knob to maximum CCW position.
4. Set signal generator for 500 uv level and search frequency for receiver output response. Use 1000 Hz, 30% AM modulation.
5. If frequency of tuner is above 420 MHz, bend endmost segment of rotor blade of C9M towards stator to lower frequency (tool must be removed to test frequency). If frequency is below 400 MHz, bend blade segment away from stator until frequency falls between 400 and 420 MHz or matches the dial, if dial has been previously calibrated. Be careful not to break stator loose from the ceramic support when prying blade segments.
6. Open or close spacing between turns of L2 and L4 with needle nose pliers or small screwdriver until maximum receiver output is obtained. This is a coarse adjustment and need not be precise. Again, be careful not to apply undue force on the stator support. As sensitivity increases, reduce signal generator gain.

TA3-7 ALIGNMENT PROCEDURE

7. Adjust L-21 for maximum output. This IF pre-amplifier coil tunes broadly.
8. Next, turn tuning knob CW to maximum position.
9. Search with signal generator at high output level from 750 to 900 MHz until output is located.
10. Bend the capacity adjust tab associated with the C9M capacitor (located below and perpendicular to the C9M stator blades) until output occurs between 815 and 835 MHz or matches the dial. To insure that the local oscillator is tracked on the high side, check for the image between 1037 and 1057 MHz. A very high signal generator level will be necessary to locate the image.
11. Bend corresponding capacity adjust tabs of C5M and C6M for maximum output.
12. Rotate knob CCW until first (smallest) segment of adjustable rotor blades are meshed with stators.
13. Find RF frequency location by searching downward with signal generator set at high level. It should be between 790 and 810.
14. With signal generator frequency set at the tuner RF frequency, adjust these first segments on C6M and C5M only as required for maximum output. If segments have to be adjusted inwardly, adjust each side evenly so that segments do not approach the stator too closely.
15. Repeat steps 12, 13 and 14 for each blade segment. Note that the higher frequency segment positions affect the lower frequency segments, but the reverse is not true due to the meshing sequence. It is imperative, therefore, to start at the top frequency and work down.
16. Place new pre-tinned cover seals marked 27 and 25 on drawing 30140-D on tuner as shown and solder in place. These covers must be completely solder-sealed to all wall edges and internal dividers to assure oscillator radiation suppression requirements.
17. Starting at the high frequency end of the band, retrim blade segments if necessary to compensate for cover capacity.
18. Solder final covers 26 and 28 into place.
19. Recheck tuner sensitivity at 5 places across the band according to paragraph 8.2 of the Receiver Testing Section.

TA3-8 ALIGNMENT PROCEDURE

NOTE: IT IS STRONGLY RECOMMENDED THAT THE ALIGNMENT OF THIS TUNER BE CONDUCTED BY THE MANUFACTURER AT HIS FACILITY SINCE SEALED COVERS MUST BE REMOVED AND SPECIAL TOOLS AND TECHNIQUES APPLIED.

1. Remove the TA3-8 tuner from the HFR chassis by removing the screws at the edge of the tuner face.
2. Connect tuner, receiver and test equipment as shown below:

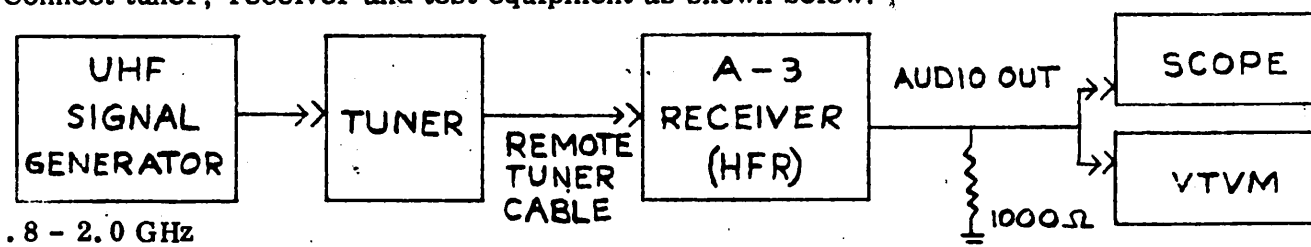

Refer to drawings SWD 4047-C, 30150-D, and PWD 4029-B for location of adjustments and components. Place the controls of the High Frequency Receiver in the wide IF bandwidth position (1 MHz), AM, Manual IF gain Max, and adjust the audio gain for convenient readout level on scope (some receiver noise should be seen on the scope). Use remote tuner cable to allow accessibility to the tuner tracking adjustments. Covers, designated on the tuner assembly drawing 30150-D with number 25, 26, 27, and 28, must be removed for alignment. To remove soldered covers, start at the corner, melting solder with iron while prying up cover with screwdriver or knife. Continue around the cover in the same manner until cover is removed. These covers are usually damaged when removed and should be replaced with new ones.

3. Turn tuning knob to maximum CCW position.
4. Set signal generator for 500 uv level and search frequency for receiver output response. Use 1000 Hz, 30% AM modulation.
5. If frequency of tuner is above 800 MHz, bend endmost segment of rotor blade of C5M towards stator to lower frequency (tool must be removed to test frequency). If frequency is below 780 MHz, bend blade segment away from stator until frequency falls between 780 and 800 MHz or matches the dial, if dial has been previously calibrated. Be careful not to break stator loose from the ceramic support when prying blade segments.
6. Adjust L-21 for maximum output. This IF pre-amplifier coil tunes broadly.
7. Turn tuning knob CW to maximum position.

TA3-8 ALIGNMENT PROCEDURE

8. Search with signal generator at high output level from 1500 to 1700 MHz until output is located.
9. Bend the capacity adjust tab associated with the C5M capacitor (located below and perpendicular to the C5M stator blades) until output occurs between 1620 and 1640 MHz or matches the dial if the dial has been previously calibrated. To insure that the local oscillator is tracked on the high side, check for the image between 1842 and 1862 MHz. A very high signal generator level will be necessary to locate the image.
10. Bend corresponding capacity adjust tabs of C1M, C2M, C3M, and C4M for maximum output.
11. Rotate knob CCW until first (smallest) segment of adjustable rotor blades are meshed with stators.
12. Find RF frequency location by searching downward with signal generator set at high level. It should be between 1585 and 1605.
13. With signal generator frequency set at the tuner RF frequency, adjust the first segments on C1M, C2M, and C4M only as required for maximum output. If segments have to be adjusted inwardly, adjust each side evenly so that segments do not approach the stator too closely.
14. Repeat steps 10, 11, and 12 for each blade segment. Note that the higher frequency segment positions affect the lower frequency segments, but the reverse is not true due to the meshing sequence. It is imperative, therefore, to start at the top frequency and work down.
15. Place new pre-tinned cover seals marked 27 and 25 on drawing 30150-D on tuner as shown and solder in place. These covers must be completely solder sealed to all wall edges and internal dividers to assure oscillator radiation suppression requirements.
16. Starting at the high frequency end of the band, retrim blade segments, if necessary, to compensate for cover capacity.
17. Solder final covers 26 and 28 into place.
18. Recheck tuner sensitivity at 5 places across the band according to paragraph 8.2 of the Receiver Testing Section.

B-2 ALIGNMENT

1. The B-2 section of the Low Frequency Receiver includes those portions from the T03/converter switch to the audio and visual outputs. Refer to drawings SWD 4031 B, PWD 4032C, PWD 30215D, 5831B and PWD 4031D.
2. To remove the B-2 from its case:
 - (a) Remove the 3 flathead screws from bottom of case.
 - (b) Remove the 9 binder head screws along the side of the case.
 - (c) Remove the B-2 from the case. Note that the T03 tuner is removed with the B-2. Care should be taken not to damage the T03 printed circuit plug. Unplug the T03 tuner and carefully lay aside.
3. Plug a VTVM into the audio output jack. Connect a 455 KHz signal generator to the B-2 through pin A of the chassis T03 plug of the B-2. The ground connection for the signal should be put on pin B.
4. Set the controls as follows:
 - (a) AM/FM Switch S16 in AM position.
 - (b) Sweep/no SWP in NO SWP position.
 - (c) AF gain R50 in mid position.
 - (d) Conv. ?T03 switch S13 in T03 position.
 - (e) AGC/Man switch S12 in Man position.
 - (f) IF Gain R37 Full CW (Max gain) position.
 - (g) BFO, S9-R65 Full CCW in off position.
 - (h) Meter SW S11 in Lo position.
 - (i) Bandwidth switch S14 in 2 KHz position (centerposition).
5. Apply power by connecting power supply to J23 and measure load current. It should be 20-30 ma.
6. Place meter switch S10 in test position - meter should indicate at or above red line. This indicates that the power supply voltage is correct.
7. Adjust signal generator frequency while bandwidth is in 200 Hz position. Adjust Capacitor C6 and Transformer T1 for Maximum reading on "S" meter to peak the gain of IF Amplifier. 10-50 uv input should give full scale deflection on "S" meter in 2 KHz bandwidth position.
8. Align BFO. Set the signal generator to 455 KHz. Place BFO control S9-R65 in center position. Set input signal to 455 KHz unmodulated with a level of 5 uv. Using an earphone at audio output, a tone should be heard. Tune coil T-3 until zero beat is obtained and seal core of coil with Q dope. The tone should increase when R65 is moved in either direction. Place BFO switch S9 in off position.
9. Align FM discriminator. Connect equipment as shown in Block Diagram. Remove Q4 and apply signal at Pin 3 of Q4 transistor socket.

B-2 ALIGNMENT

10. Place AM/FM switch in FM position.
11. Place bandwidth switch S14 in 10 KHz position.
12. Tune sweep generator for display on scope and adjust sweep width and sweep rate for best display.
13. Adjust the pink core of T4 for maximum output. Adjust the blue core of T4 for "S" curve crossover at 455 KHz. Peak to peak separation of "S" curve should be 20 KHz. Put Q4 back into socket. Disconnect all connections. Replace the unit in case. If C2 is not aligned, do that before putting this unit into box as the C2 is on the same chassis as the B2.

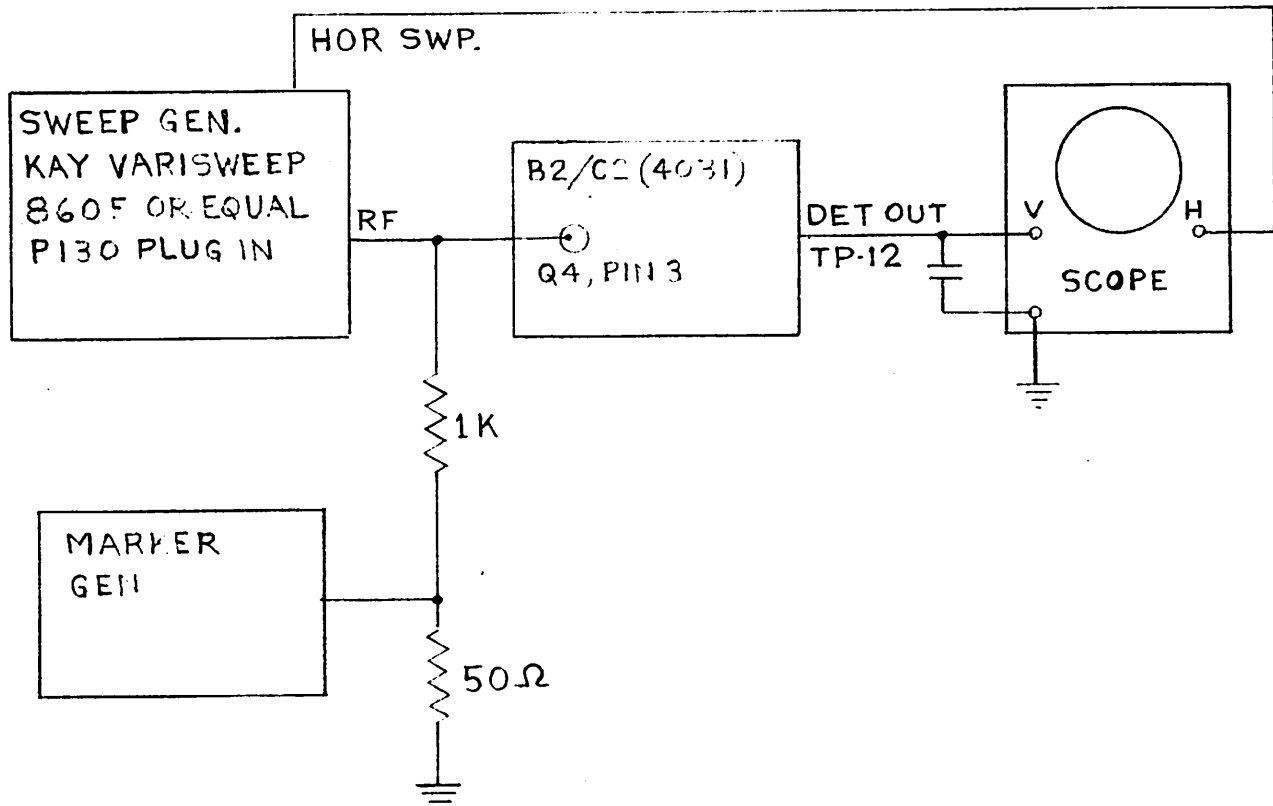

C2 ALIGNMENT

1. The C2 consists of that portion of the Low Frequency Receiver which includes the 26 MHz low pass filter, 23.5 MHz to 10.7 MHz converter and 10.7 MHz to 455 KHz converter. Refer to drawings SWD 4033C, PWD 4033C, SWD 4035C and PWD 4035C.
2. To remove the B-2 from its case:
 - (a) Remove the 3 flathead screws from bottom of case.
 - (b) Remove the 9 binder head screws along the side of the case.
 - (c) Remove the B-2 from the case. Note that the TO3 tuner is removed with the B-2. Care should be taken not to damage the TO3 printed circuit plug. Unplug the TO3 tuner and carefully lay aside. The C2 section is the cast aluminum chassis holding the TO3 socket.
3. Connect a 23.5 MHz signal generator to the B-2 through J17 (converter in). Set the level to approximately 100 uv.
4. Set the controls as follows:
 - (a) AM/FM Switch S16 in AM position.
 - (b) Sweep/no SWP in NO SWP position.
 - (c) AF gain R50 in mid position.
 - (d) Conv./TO3 switch S13 in Conv. position.
 - (e) AGC/Man switch S12 in Man position.
 - (f) Meter switch S11 in Lo Position.
 - (g) IF Gain Control R37: position so that S meter reads half scale.
 - (h) BFO, S9-R65 Full CCW in off position.
 - (i) Bandwidth switch S14 in 2 KHz position (Center position).
 - (j) Sig cent control R13 in mid position.
5. Apply power by connecting power supply to J23 and measure load current. It should be 20-30 ma.
6. Place meter switch S10 in test position - meter should indicate at or above red line. This indicates that the power supply voltage is correct.
7. Use the S meter as an indicator. It will be necessary to decrease the IF gain control as the various stages are aligned to bring the S meter back to a half scale reading.
8. Referring to SWD 4033, tune L-2, the output coil associated with Q4(2N3646 - 34.2 MHz swept local oscillator) until the S meter indicates a maximum.
9. Tune T1, the output transformer of Q6 - the 10.7 MHz output stage) until a maximum is reached on the S meter.
10. Tune C29, the output capacitor of Q8 - The 10.245 MHz local oscillator) until a maximum is reached on the S meter.

C2 ALIGNMENT

11. Tune T-2, the output transformer of Q7 - the 10.7 MHz to 455 KHz mixer) until a maximum is reached on the S meter.
12. Alignment of the C2 is complete. Replace the B2/C2 chassis in its case.

TA3-03B ALIGNMENT PROCEDURE

1. The TA3-03B tuner may be removed from the case by removing the 3 binder head screws on the side of the low frequency receiver case. The TA3-03B tuner may now be pulled through the top of the LFR case. When making the following adjustments refer to drawings PWD 4021C and SWD 4021B.
2. Connect tuner to low frequency receiver using remote cable. Set controls on low frequency unit in following positions.

AM/FM Sw.	-	AM Pos.
No SW/Sweep	-	Swp. pos.
AF Gain	-	CCW Pos.
Converter/TO3	-	T03 Pos.
IF Gain	-	CW Pos.
BW	-	20 KHz Pos.
BFO	-	Off
"S" Meter Hi/Lo	-	LOW
AGC/Man.	-	Man. Pos.
Sig. Cent.	-	Cent. of Rotation

Note: The signal center control on LFR is used to set 23.5 MHz center only. It has no effect on TA3-03B tuner.

3. Connect LFR to S-3 with coaxial cable "Sweep in" to "Sweep out" and "Pan out" to "Pan in". Set controls on S-3 in following positions:

SWP Width	-	25 KHz/Div.
Sweep Time/Div	-	20 - 100 ms
Sweep Vern.	-	Center
Syn	-	CW
INT/EXT SYNC	-	INT
AMP/PAN	-	PAN
4. Connect signal generator to tuner antenna connector using BNC Cable.
5. Rotate tuning knob clockwise dial reading of 300 KHz and set signal generator to 300 KHz, 10 microvolt output level.
6. Set R11 for 0.8 volt at terminal "2" of the 10-turn pot.
7. Adjust L2 to bring signal to center of the screen. Change BW switch at LFR to .2 KHz position and progressively change SWP WIDTH switch to .25 KHz position, trim L-2 to exact center. After that, leave LFR BW and S-3 swp width as is, and proceed to "8".
8. Rotate the tuning knob to 2 KHz and set signal generator to 2 KHz.

9. Adjust R9 until the signal is at the center of the S-3 screen. Notice that at the right hand edge there is an 455 IF peak. Move the signal generator to 2.5 KHz. The signal should move two divisions to the left and the IF remains stationary. If it moves to the right, the R9 setting is wrong, and you are seeing the image of 2 KHz. Turn R9 counterclockwise to bring the right signal in.
10. Repeat procedure "5 & 6". See that the voltage at Terminal "2" is still 0.8 volt. Reset it, if necessary, and repeat 7 to 9.
11. If 10 is o.k. reduce the signal generator output level to 1 uv. The signal should be visible on the screen to indicate that the sensitivity of the tuner is up to standard.

VISUAL DISPLAY UNIT S-3 ALIGNMENT

1. All of the following controls referred to are located on the outside control panel and appear as recessed screwdriver adjustments. The trimpots numbered R20, R27, R29, R47, R48 and R50 may be exposed by removing the 2 binder head screws holding the 2" x 3/4" cover on the face of the VDU front panel. These trimpots control the sweep output circuit. Note that the R numbers and SWP width position numbers appear on either side of the screwdriver adjustments.
2. Set S-23 (SWP RATE) to the 135-700 us position, set R2 (SWP VERN.) to full counterclockwise. Set S-22 (SWP WIDTH) to .3 KHz/DIV. and connect power supply. Adjust R20 to obtain 7.9 volts dc at J-27 (SWEEP OUT). Use a VTVM at J-27 to measure voltage.
3. Turn S-22 to 500 KHz/DIV position. Adjust the saw-tooth output to 1.2 volt RMS (saw-tooth p-p 4 volts) with R-27. Adjust R29 to obtain 7.9 volts average dc output. After the dc adjustment, see that the saw-tooth output is still 1.2 volt RMS. If not, readjust to that value with R27 and adjust R29 for dc value again.
4. Turn S-22 to 120 KHz/DIV position and adjust R47 to obtain exactly the same dc output voltage as before.
5. Repeat procedure 4 for the 30, 6 and 1 KHz/DIV positions and adjust R48, R49 and R50 respectively for 7.9 V DC.
6. Connect equipment as shown in block diagram.

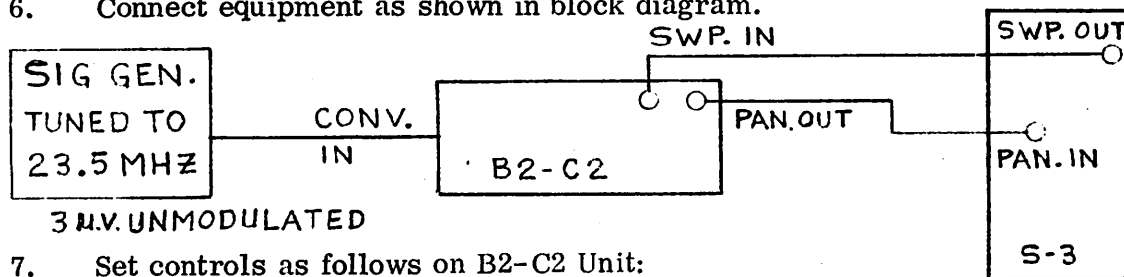

7. Set controls as follows on B2-C2 Unit:

AM. FM Sw.	-	AM
Swp. No Swp. Sw.	-	No Swp.
Bandwidth Sw.	-	.2 KHz
T03/Conv. Sw.	-	Converter
AGC/MAN Sw.	-	Man
Hi/Low Sw.	-	Lo
IF Gain	-	Max. CW
BFO	-	OFF
Sig. Cent.	-	Center of Range.

S-3

SWP. VERN.	-	2
SWP. RATE	-	20 100 us
SYNC.	-	0
INT./EXT. Sync Sw.	-	INT.
AMP/PAN Sw.	-	PAN
Swp. Width Sw.	-	.3 KHz/Div.

8. Using S-3 graticule for calibration, adjust Swp. Gain and Cent. for full scale (10 divisions on graticule).
9. Tune generator to peak signal on S-meter.
10. Switch B2-C2 sweep select switch to Sweep and adjust R20 on S-3 until swept signal is centered on S-3. Switch S-22 (Swp. Width) to 500 KHz/Div. and B2-C2 bandwidth switch to 2 KHz. Adjust R-29 to center swept signal. Repeat for R-47 and R-48 switching S-22 (Swp. width) to corresponding sweep width positions. Switch B2-C2 BW switch back to .2 KHz and repeat procedure for R-49 and R-50.
11. Return S-22 to 500 KHz/Div. Tune signal generator until swept signal is positioned at extreme line on S-3 graticule and note frequency on generator. Repeat for opposite end of S-3 graticule. Difference between two ends should be 5 MHz.
12. If sweep width is less than 5 MHz, adjust R-27 CW increasing P. P. sawtooth output at J-27 above 4v and readjust R-29 for center at 23.5 MHz. Continue this procedure until 5 MHz sweep width is obtained.
13. If Sweep width is more than 5 MHz the opposite adjustments to step 12 are necessary.

PS-10 ALIGNMENT

1. CHECK THE 1/4 AMP FUSE:
2. Refer to drawings SWD 4074B, PWD 4074D, and 30410-D for the schematic diagrams for the AC power supply.
3. Remove the 2 pan head screws on lower side of the power supply.
4. Remove the 2 small pan head screws top of the case.
5. The circuit board with transformer may now be pulled from the case.
6. Switch power on.
7. Measure voltage across C1. It should be 23 ± 2 volts.
8. Measure voltage across C3. It should be 20 ± 1 volts. Measure output voltage across the output terminal and adjust it to 18 volts by R4.
9. Switch power off.
10. Connect 60 ohms (10 W) resistor across output terminals of PWD-4074B. One of the receivers may be used as a load in which case the S meter will be the indicator.
11. Switch power on again and measure the output voltage of PS-10. It should be $18 \pm .2$ volts.
12. Connect a VTVM to the output terminals of PS-10. The ripple voltage should not be more than 1 mv.
13. Disconnect the circuit. Test is completed.
14. Return the circuit boards and transformer to the case and tighten screws.

BP-7 BATTERY PACK

1. There are no adjustments on the BP-7 Battery Pack.
2. To replace batteries, remove the 3 flat head screws on the cover containing the printed instructions. Remove the cover.
3. Remove the old batteries by inverting the battery pack.
4. Replace the batteries as marked on the cover observing the battery polarities. The following batteries or their equivalent are suggested for use:

RM - 12R	E91
N46	915

5. Check Battery Polarities.
6. Replace cover by fastening the lid with the 3 flat head screws.
7. Check voltage using the meter on either receiver in battery test position.

PART EIGHT: OPERATIONAL TESTS, RECEIVER MODES

8.0 This section provides the depot Repair and Inspection personnel with a procedural guide to assure that the equipment is functioning properly before sending it into the field for use. Data sheets A thru D of PART FOURTEEN may be used as sample forms to record this data. In most tests go / no go records suffice. Actual measured levels may be desirable when tracing malfunctions.

8.1 AM SENSITIVITY AND DIAL ACCURACY

(Reference MIL-STD-449 C, Paragraphs 3.18, 5.3.2, 5.3.3 and 5.3.4. Note however, that with the A-3 specifications, 25% meter deflection or 10 dB of S+N/N is the required standard signal rather than 6 dB of S+N/N.) Sensitivity tests are taken at three points in each band - the lower and upper ends of the dial and one middle point. These points assure that the unit is properly functioning across the required RF range. Dial accuracy data is also taken with sensitivity tests.

TEST SETUP:

Refer to Figure 13.1. The equipment required is:

1. Signal Generators covering a frequency range of 80 KHz to 2 GHz. The output level and frequency must be calibrated. These generators must have 30% 1000 cycle amplitude modulation. Also 2 to 80 KHz signal generator with calibrated level output, no modulation required.
2. AC VTVM with frequency response to 5 MHz and maximum voltage range of at least 10 volts. Scales should also be calibrated in decibels.
3. 1000 ohm resistor.
4. 50 ohm matching pads.
5. Connecting cables.

Connect equipment as shown in Figure 13.1. (Use counters for more accurate dial calibration as in Figure 13.2 if desired.) Set LF Receiver as per instructions in section 6.1 except connect signal generator and output meter with 1000 ohm resistor instead of antenna and ear phone. Also set bandswitch to 200 Hz and audio gain to minimum. Set generator to 2 KHz at 1.5 microvolt level by setting attenuator strip and generator level control. Center "signal center" control. Adjust TA3-03 Tuner until S meter peaks on signal. S meter should deflect at least 25% with meter switch on low signal position. If deflection is o.k., check appropriate box on test sheet. If dial is within 1/8" of

proper position also check appropriate box under "dials" on test sheet. Next, set Receiver to 100 KHz RF and 2 KHz bandwidth and audio gain for about .1 volts of noise on VTVM output meter with no input signal. Then set generator to 100 KHz RF with 1000 Hz, 30% modulation at 1.5 microvolts level allowing for pads and peak output meter response by tuning tuner. Now remove modulation from carrier and read output level. Output level should drop 10 dB or more. If so check appropriate box as o.k. Dial position should be within the limits shown on the data sheet and appropriately checked. Proceed in the same manner for all test frequencies from 100 KHz to 1600 MHz. Be sure to set proper receiver bandwidth for each RF frequency as required by specification Paragraph 3.2 and as shown on test data sheet. Also set generator level as shown on test data sheet. Fine tune control should be centered. Some signal generators above 1200 MHz have no built in AM modulation, therefore external modulation must be applied and calibrated. Another method is to cross calibrate the internal square wave on pulse modulation with the next lower signal generator having AM modulation in the RF overlap region. The factor thus found may be used to correct for square wave or pulse modulation throughout the upper band. It may be useful to display the output wave shape when using sine wave modulation to check for distortion or stray signals. All sensitivity tests should be done in a screen room and with shielded cables to avoid stray pickup. Receiver should be in maximum IF gain condition when making these measurements.

8.2 FM QUIETING:

(Reference MIL-STD-449C, Paragraph 3.18, 5.3.2, 5.3.3, and 5.3.4)

TEST SETUP:

Same as for AM sensitivity, Paragraph 8.1 Figure 13.1. Set LF receiver controls as in Paragraph 6.1 except AM/FM switch to FM. When testing the HF receiver the AM/FM switch should be in FM and FM Wide/Nar should be in Nar position. For FM, use generator with no modulation. Start at 100 KHz, since at the 2 KHz point the FM is inoperable. Set generator at 100 KHz and tune in receiver for maximum S meter deflection. Detune signal generator and set audio gain and VTVM output meter for .1 volts of receiver noise. Set generator level at 3 microvolts allowing for pads. Then tune in signal generator for maximum drop in output meter reading. The drop in output meter reading should be 20 dB or more than the original reading. Fine readjustment of signal frequency may be necessary to peak signal quieting. Proceed in the same manner for all test point frequencies on data sheet taking note to adjust the receiver bandwidths as shown and signal generator levels as shown.

8.3 BANDSPREAD: (Fine Tune)

Data Sheet B is set up for tests that require one reading of each test in each band. It is therefore expeditious to set each tuner at the RF frequency shown on the test data sheet and then perform each test across all tuners before going to the next test. Again, specification requirements are shown.

At each test frequency using setup 13.2, measure plus and minus frequency extreme of bandspread control. Using 2 KHz IF bandwidth, set bandspread control to C. W. extreme and peak S meter by adjusting signal generator frequency. Repeat for the C. C. W. extreme and record the difference of the two frequencies. Several peaks may occur within the band pass of the IF. To avoid confusion always use lowest frequency peak. If tuning range of Fine tune control is in excess of minimum requirement, it is only necessary to check the appropriate box on data sheet.

8.4 IF REJECTION:

With tuner set at frequency shown (Sheet B), set signal generator at IF frequency shown and with level set at the DBM value shown. Allow for Pads. (-50 DBM = -30 DBM on signal generator +20 dB fixed Pad) (Use 1000 Hz AM modulation at 30%). Peak output signal by tuning generator slightly. If less than 10 dB S+N/N is shown by output meter, check appropriate box as o.k. In many cases, no output will occur indicating that the rejection level is much better than required. (The IF and Image DBM levels were calculated from the specification by changing the UV sensitivity specification level of the receiver at the RF frequency, to its equivalent in DBM and subtracting the dB rejection specification. This means that if the sensitivity is better than minimum specification and the test for rejection is made and found o.k. as indicated above, then the rejection is better than specified. If not, then an absolute reading must be taken by comparing the dB levels of the tuned RF signal and the spurious response for the same output level.)

8.5 IMAGE REJECTION:

Proceed in the same manner as taking IF rejections only use image frequencies instead of IF frequencies.

8.6 Local Oscillator Radiation:

To measure the local oscillator voltage level at the antenna terminal, connect the antenna terminal of the receiver under test to the antenna input terminal of a second receiver. Tune the second receiver to the local oscillator frequency of the first receiver. The local oscillator frequency is found by

adding the RF (dial reading) to the first IF frequency. IF frequencies for the individual tuners are: T03, 455 KHz; T1/T3, 23.5 MHz; T4, 111 MHz; T5 23.5 MHz, T6/T8 111 MHz. Note the "S" meter reading of the second receiver. Then calibrate this level by substituting a signal generator for the first receiver, setting the generator frequency and level to indicate the same "S" meter reading. This level is then the voltage level of the local oscillator at the antenna terminal.

8.7 IF BANDWIDTHS:

Use test setup as per Figure 13.2. Since most counters require a high input signal level, be sure that generator frequency does not shift when increasing output to read the counter. If possible, couple counter in so as to read at all times without signal generator level changes. This is the purpose of coupling the counter in before attenuation to receiver level of signal. The A3 receiver requires measurement of bandwidth by unmodulated CW signal with S meter read out rather than modulated wave with audio readout. This is because some bandwidths are too narrow to pass the 1000 Hz modulation side bands, and the ceramic and crystal filters distort audio modulation when measuring slopes. L. F. R. Bandwidths are measured with input at 60 KHz through the T03 Tuner. The 2 KHz and 20 KHz Bandwidths of the HFR are measured at 600 KHz RF input (T1). The 90 KHz and 1 MHz bandwidths are measured at 23.5 MHz at the "Wide IF Output" Jack, with Tuner Select Switch on "Ext" position.

PROCEDURE:

Set generator to test frequency. Set receiver to test frequency. Set AGC/MAN

switch to Man. AM/FM switch to AM. MAN Gain to maximum. S meter switch to Lo. Fine tune receiver to center the signal in band pass response. Set attenuators and signal generator level so that S meter reads on Red line. Proper settings should allow counter to operate at the same time. Set bandwidth switch to test BW. Increase signal level by removing 10 dB attenuation from attenuator strip. Tune generator far below center frequency then approach tuning point until S meter reads original red line point. Note counter reading. Now turn generator frequency way above counter frequency. Then slowly lower frequency until meter climbs to red line and read the counter. If difference of these two readings is within the limits shown, mark as o.k. Repeat the above procedure for all frequencies and bandwidths required.

8.8 SWEEP WIDTH:

The panadapter mode dispersion is a measure of the spectrum width visible under the test conditions in the panadapter mode. Since dispersion is basically a function of the low frequency receiver and visual display unit circuitry, it varies only slightly at different RF frequencies due to RF bandwidth limitation. RF test frequencies are chosen for ease of measurement.

TEST SETUP:

Set up panadapter mode in accordance with Paragraph 6.3 of the Operation Procedure. Set high frequency receiver to test frequency and connect the corresponding signal generator to the tuner antenna connector. Set signal generator to test frequency at 10 uv level. Set sweep width position of VDU to the 500 KHz/DIV position. Use minimum useable bandwidth of LFR and best sweep rate consistent with a visible high resolution pip on the display screen. Move PIP to extreme left side of screen by adjusting signal generator frequency and note frequency. Then move PIP to extreme right side of screen in the same manner and note frequency. The frequency difference is the total dispersion for these test conditions. If within the specified limit (Sheet C) mark as o.k. Repeat the above procedure for all sweep width positions. Note that some PIP amplitude changes may occur across the screen due to RF bandpass limitations.

Set LFR controls for T03 sweep as per Paragraph 6.4.1 and 6.4.2 and proceed to measure sweep width for T03 operation (Sheet C).

For centering check for both T03 and HFR, set signal in center at minimum sweep width. Signal should remain on screen at next to minimum Sweep Width position and within \pm one screen division at all other positions. Use RF and BW positions shown on Sheet C.

8.9 SWEEP RATE

Connect Sweep out jack of S-3 to frequency counter. Set sweep width control to maximum sweep width, full CCW. Set sweep rate to full CW position (highest sweep rate). Set Sweep Vernier full CW position (highest vernier rate). Counter should read a higher frequency than the upper frequency requirement shown for that position. Upper and lower frequency requirements are shown on Sheet C of test data as calculated from time base ranges shown on S-3 monitor. These ranges indicate the minimum coverage of that particular switch position. In all cases these ranges should be exceeded. In each switch position test for meeting or exceeding upper and lower frequency requirements and check appropriate box.

8.10 S3 VERTICAL SENSITIVITY

The rest of the receiver checkout tests are taken under one set of conditions only and are go/no go type tests. They cover controls and jacks not previously used for other tests.

Set visual display unit up as per Paragraph 6.8 of the Operating Instructions. For vertical amplifier tests, set controls as per Paragraph 6.8.2, maximum vertical gain, attach signal generator to signal input jack and set for 1000 Hz CW, 50 or 600 ohm impedance or less. Adjust level of generator until one large division of vertical deflection is displayed. Signal generator level should be less than 1 millivolts. Check item off if o.k.

8.11 SIGNAL GAIN CONTROL

Next, adjust signal gain control to minimum and reset signal generator level for one division of vertical deflection. The differential between the first and second signal generator level reading should be 50 dB or greater. Check item off if o.k.

8.12 VIDEO BANDWIDTH

With same set up as above, set vertical gain control to maximum. Set generator to 1000 Hz and level to produce two main vertical divisions deflection on screen. Then increase generator level by 3 dB and adjust frequency to 1 Hz. Original or greater deflection should be observed. At same generator level (3 dB above 1000 Hz setting) move frequency to 1.8 MHz. Deflection should be greater or the same as at 1000 Hz.

8.13 Z AXIS SENSITIVITY

For Z axis sensitivity, set intensity control halfway between maximum bright and cutoff. Then insert a 1000 Hz square wave signal into Z axis jack and

adjust signal generator level until full brightness and cutoff occurs. Peak to peak voltage of square wave required as Z axis sensitivity should be 40 volts P. P. or less.

8.14 BRIGHTNESS CONTROL

Brightness control should provide full beam cut off at full CCW.

8.15 FOCUS CONTROL

With sweep rate switch in "0" position, focus control should adjust focus of dot to blurred image on both sides of sharp focus.

8.16 SWEEP CENTERING CONTROL

Sweep Centering Control should adjust base line to either side of center.

8.17 SIGNAL CENTERING CONTROL

In "amp" position of Amp/PAN Switch signal centering control should adjust base line from center screen vertically to bottom graticule base line or more.

8.18 SYNC CONTROL

With S3 controls set for vertical amplifier use and sync switch in internal position, and sync control center position, insert 1000 Hz sine wave in signal in jack. Adjust signal input level and sweep rate so that sine wave display is slightly out of synchronization. Now adjust sync control until sine wave is synchronized on screen.

8.19 EXTERNAL SYNC JACK

Now switch "INT/EXT SYNC" switch to ext. Sine wave should now be out of sync. until external sync signal is applied by connecting the signal input and the external sync jacks together with the signal generator. A higher level of generator output may be required to operate the external sync.

8.20 SWEEP GAIN CONTROL:

Sweep gain control should adjust the base line length to less than or more than 10 divisions.

8.21 LFR HI-LOW METER SWITCH

With LFR set for T03 receiver operation, 10 KHz BW, insert 100 KHz signal in T03 antenna and tune and level with generator for full deflection of S meter with S meter switch in LOW position. Then switch meter to Hi position. Meter reading should drop to approximately 2.

8.22 LFR IF GAIN CONTROL

With same set up as 8.21, and AGC/Man switch set in manual position, manual gain maximum, set signal generator level for full meter deflection with meter switch in Hi position. Now turn IF gain control to minimum position and S meter should read at or near zero in lo meter switch position.

8.23 LFR AGC TEST JACK

With same set up as above set AGC/Man switch in AGC position and attach high impedance V. T. V. M. between AGC test jack and ground. With no signal input to tuner DC voltmeter should read between +4.2 and +5.2 volts. With .1 volt level signal input DC voltmeter should read less than 3.0 volts.

8.24 LFR DETECT OUT JACK

With same test set up as above, insert 10 uv, 1000 Hz 30% AM modulation at 100 KHz RF to T03 antenna with receiver in AM, 10 KHz bandwidth position. Attach an oscilloscope vertical input to the Detect out jack. The 1000 Hz modulation wave should appear on scope.

8.25 LFR AUDIO OUTPUT

With same setting as above, measure audio output voltage at audio output jack with AF gain maximum. 5 uv input 1000 Hz, 30% modulated AM, should produce a minimum 2.5 volts out across a 1000 ohm resistor, with manual IF gain set for 8 on S meter low switch position.

8.26 LFR IF OUT JACK

Switch LFR controls to NO SWP and CONV. Attach signal generator at converter input and set to 23.5 MHz, no modulation and 30 uv signal level. Attach oscilloscope to IF output jack. A 455 MHz (approximately) signal should appear on oscilloscope.

8.27 LFR BFO TEST

With same set up as above (100 KHz RF, No modulation, 10 uv level input 10 KHz BW) and with earphones attached, turn BFO on. Beat frequency tone should be heard and be able to be reduced to zero beat with BFO control on RF tuning.

8.28 HFR HI-LOW METER SWITCH

Proceed in the same manner as 8.21 for the HFR Meter Switch test, only use 100 MHz input (T5) and 90 KHz in this and the following HFR tests.

8.29 HFR IF GAIN CONTROL

Proceed with same test as was done on LFR Paragraph 8.22.

8.30 HFR AGC TEST JACK

Proceed with same test as was done on LFR, Paragraph 8.23.

8.31 HFR DETECT OUTPUT AND SWP JACK

Connect cables and adjust switches and controls for tuner sweep mode as per Paragraph 6.4.4 and 6.4.5 of the operating instructions. Set sweep width switch of S-3 to maximum setting. Set HFR IF BW to 90 KHz and AM/FM switch to AM. Check tuner sweep operation by locating signal response of signal generator (attached to T5 input and set at 100 MHz approximately. No modulation, 10 uv input level at center of screen. Signal response curve should occupy less than 2 divisions of the base line.

8.32 HFR AUDIO OUTPUT

Proceed with same test as was done on LFR, Paragraph 8.25.

8.33 HFR BFO TEST

Proceed with same test as was done on LFR, Paragraph 8.27.

8.34 BP7 BATTERY PACK TEST

Connect one battery pack at a time to receiver system with all circuits on and press momentary battery test switch on either HFR or LFR. Meter should read red line or above if batteries are fresh. Then connect both packs and repeat test to check interconnecting cable terminals.

8.35 ACCESSORY CHECK

Check accessories for complete list and condition.

1	24	25	26	27	28	29	30
31	32	33	34	35	36	37	38
39	40	41	42	43	44	45	46
47	48	49	50	51	52	53	54
55	56	57	58	59	60	61	62
63	64	65	66	67	68	69	70
71	72	73	74	75	76	77	78
79	80	81	82	83	84	85	86
87	88	89	90	91	92	93	94
95	96	97	98	99	100	101	102

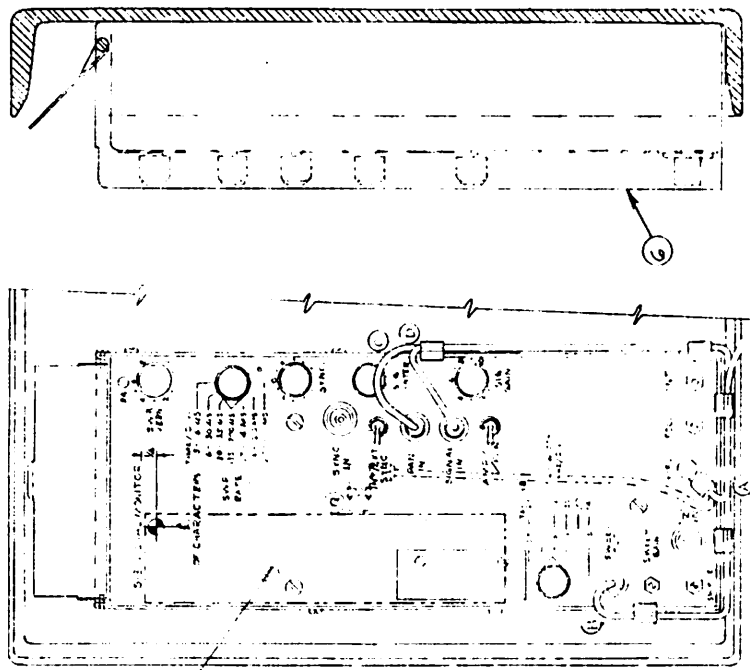
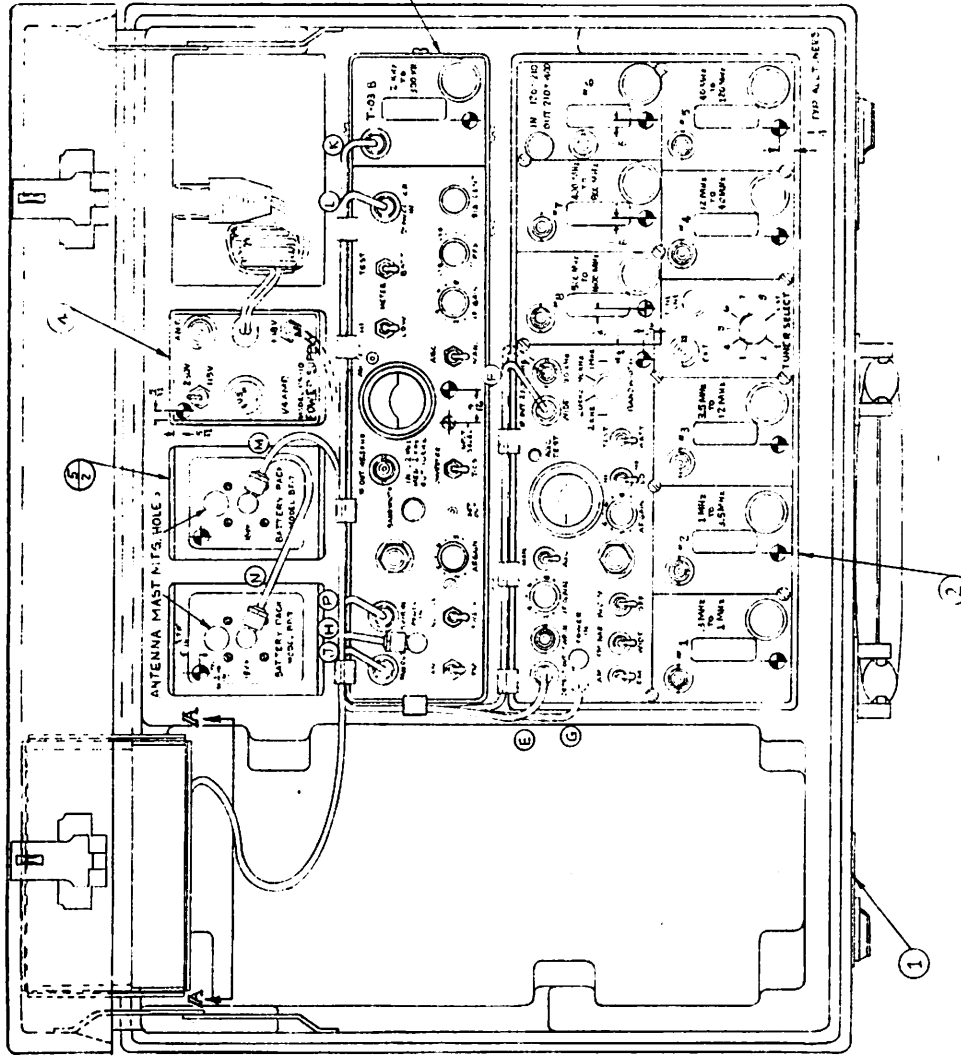

SECTION A-A

NOTE:
 1. THIS DRAWING IS A SPECIAL DRAWING.
 2. THIS DRAWING IS A GENERAL DRAWING.
 3. THIS DRAWING IS A GENERAL DRAWING.

THIS DWG. USED ON SER. NO. R. 100

* THIS PART LIST DOES NOT APPLY
 IF PART IS REQUIRED SEE PART
 LIST FOR DATE E.C. 11-24-54

PART NO.	PART NAME
9	30740-A ACCESSORY KIT AC-5
8	30750-C TV-1 ADAPTER ASSY
7	30750-A ACCESSORY KIT AC-5
6	30750-C MONITOR ASSY (S-3)
5	30750-C BATTERY PACK BF-7A5X
4	30750-D POWER SUPPLY PS-10
3	30750-D LOW FREQ. REC. ASSY
2	30750-D HIGH FREQ. REC. ASSY
1	30750-D ATTACHE CASE ASSY
CUR. NO.	
REV. NO.	

WITH TV-1 ADAPTER SEE NOTE 2
 WITHOUT TV-1 ADAPTER

WITH TV-1 ADAPTER SEE NOTE 2
 WITHOUT TV-1 ADAPTER

WITH TV-1 ADAPTER SEE NOTE 2
 WITHOUT TV-1 ADAPTER

WITH TV-1 ADAPTER SEE NOTE 2
 WITHOUT TV-1 ADAPTER

WITH TV-1 ADAPTER SEE NOTE 2
 WITHOUT TV-1 ADAPTER

WITH TV-1 ADAPTER SEE NOTE 2
 WITHOUT TV-1 ADAPTER

WITH TV-1 ADAPTER SEE NOTE 2
 WITHOUT TV-1 ADAPTER

WITH TV-1 ADAPTER SEE NOTE 2
 WITHOUT TV-1 ADAPTER

FIGURE 10.1

DATE	11-24-54	MRD-30000-D
DESIGNED BY		
DRAWN BY		
CHECKED BY		
APPROVED BY		
SCALE		
SHEET NO.		
TOTAL SHEETS		
PROJECT NO.		
WORK CENTER		
REVISIONS		

MASTER R.F.E. DRAWING

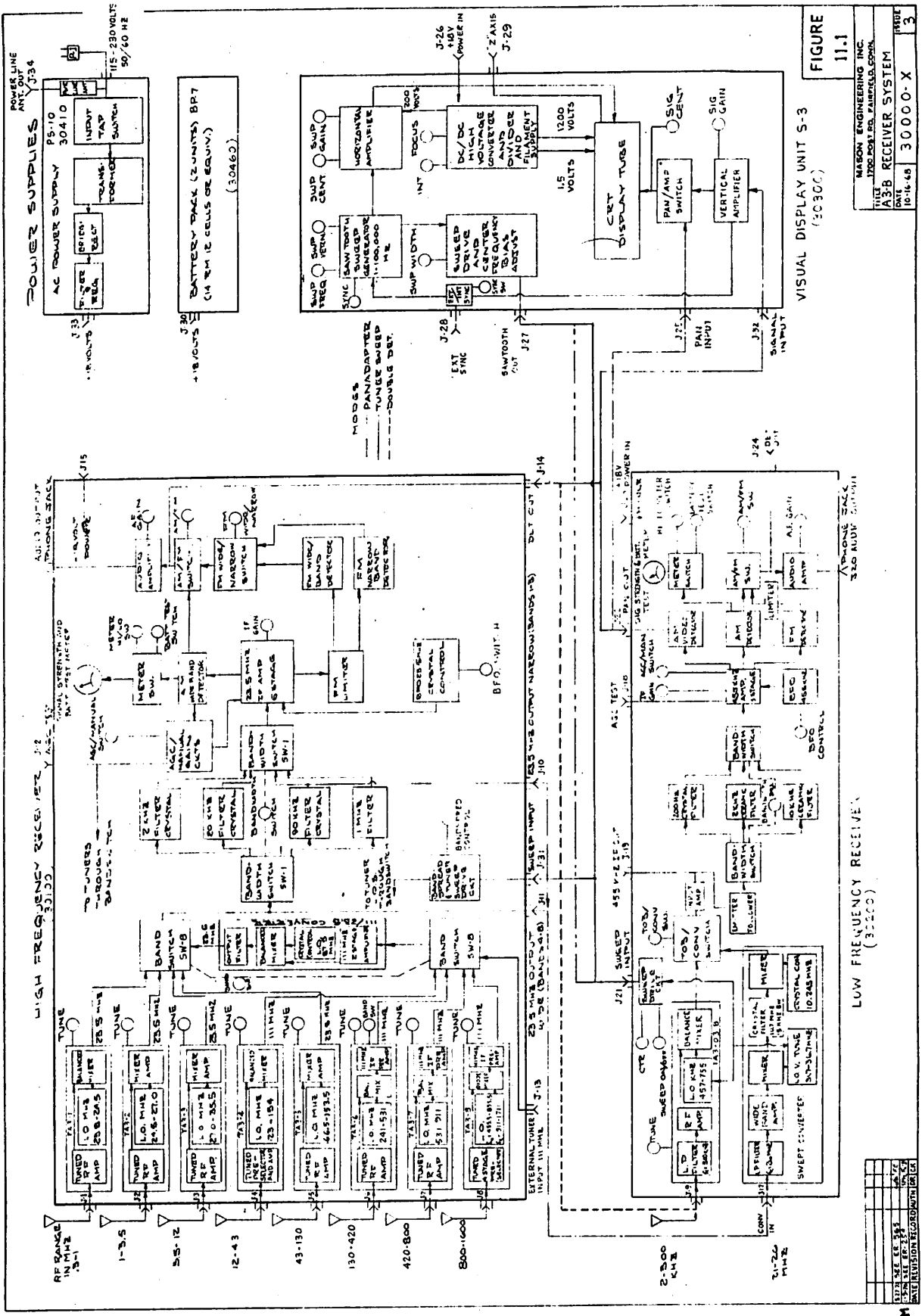

FIGURE 11-1
VISUAL DISPLAY UNIT S-3 (30300)

WACON ENGINEERING INC.	30000-X
TITLE: A3-B RECEIVER SYSTEM	3
DATE: 10-16-45	

LOW FREQUENCY RECEIVER (30300)

DATE: 10-16-45	3
DATE REVISION RECORD WITH OR	

DATE	SYMBOL	REVISION RECORD	AUTH.	DR.	CHK.
6-12-69		SEE ER-169			
8-7-69		SEE ER-214			
8-7-69		SEE ER-350			
8-7-69		SEE ER-462			
8-7-69		SEE ER-559			
8-7-69		SEE ER-585			
8-7-69		SEE ER-842			

* INDICATES TRIMMER ON MEI 2516-B
* C3 & * C4 NOT USED

SHIELDED ENCLOSURE

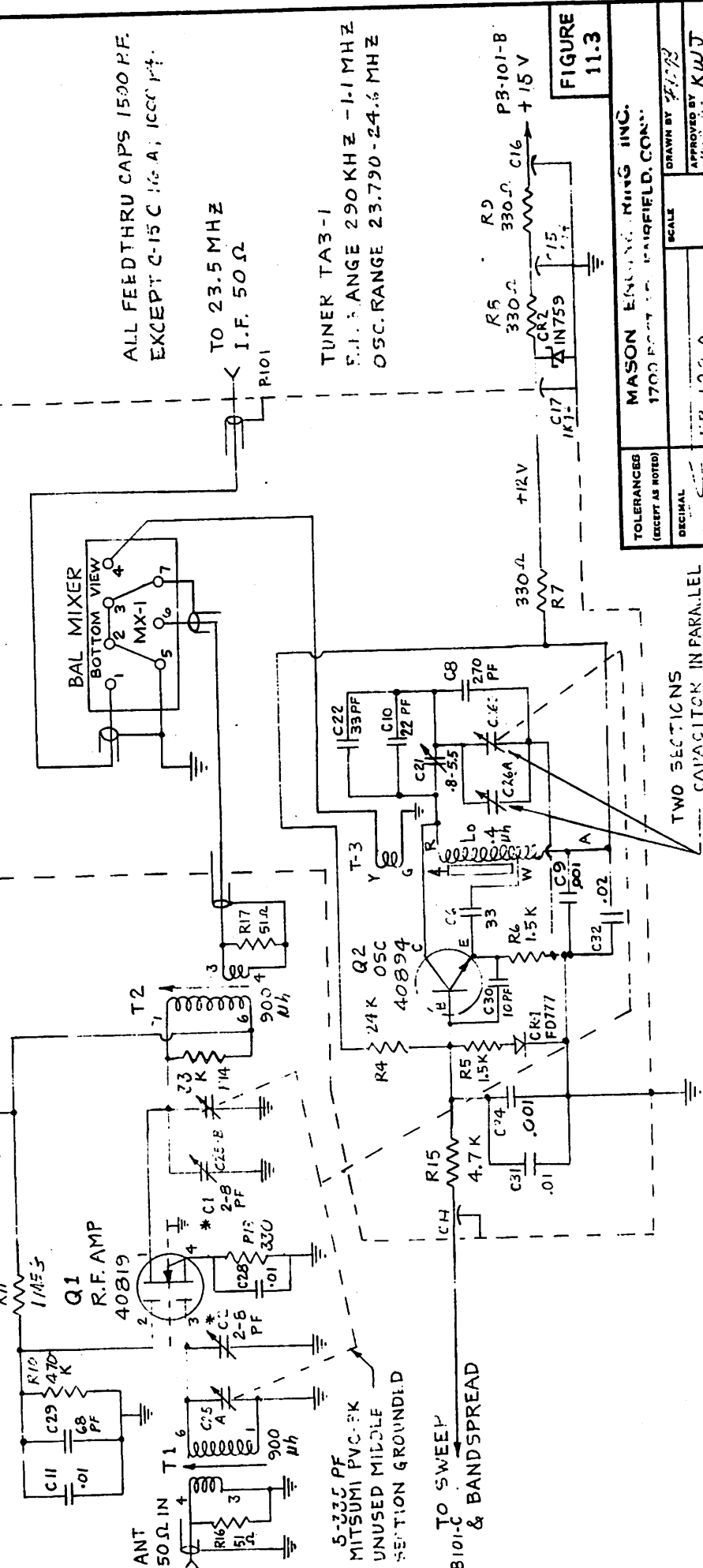

ALL FEEDTHRU CAPS 1500 P.F.
EXCEPT C-15 C 10-A; 1000 P.F.

TO 23.5 MHZ
I.F. 50 Ω

TUNER TA3-1
S.F. RANGE 290 KHZ - 1.1 MHZ
OSC. RANGE 23.790 - 24.6 MHZ

FIGURE
11.3

TOLERANCES (EXCEPT AS NOTED)	MASON ENGINEERING INC. 1700 BOSTON ST. HAIRFIELD, CONN.	
DECIMAL	SCALE	DRAWN BY <i>FJR</i>
FRACTIONAL		APPROVED BY <i>KWJ</i>
ANGULAR		TITLE SCHEMATIC WIRING DIAGRAM TA3-1
	DATE	DRAWING NUMBER SWD-4023-E 9

TWO SECTIONS IN PARALLEL
5-126 PF WITH INTERCAL TRIMMERS.

DATE	SYM	REVISION RECORD	AUTH.	DR.	CHK.
7/21/68		SEE ER-169			FB
7-1		SEE ER-137			FB
7-24		SEE L1 214			FB
7-6		SEE ER-354			FB
7-7		SEE ER-441			FB
8-31		SEE ER-542			FB

* INDICATES TRIMMER ON MEI 2516-B
 * C3 & * C4 NOT USED

RF TUNING RANGE 1-3.6 MHz
 OSC RANGE 24.5 - 27.1 MHz

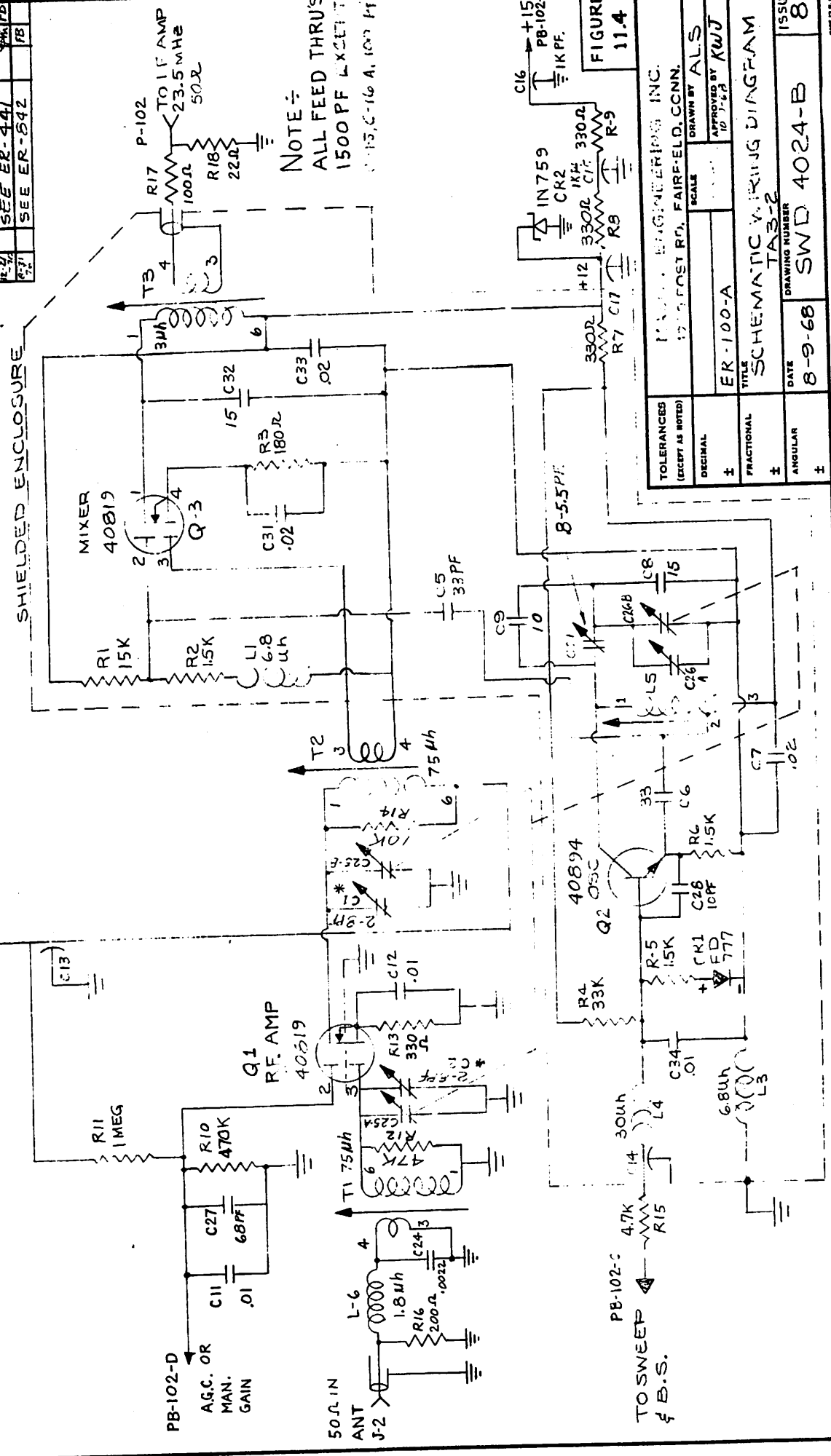

NOTE: ALL FEED THRU'S 1500 PF EXCEPT 100 PF AT +15V

FIGURE 11.4

TOLERANCES (EXCEPT AS NOTED)	±
DECIMAL	±
FRACTIONAL	±
ANGULAR	±

TITLE: SCHEMATIC WIRING DIAGRAM
 DRAWING NUMBER: SWD 4024-B
 DATE: 8-9-68
 ISSUE: 8

APPROVED BY: ALS
 DRAWN BY: KWT
 SCALE: 10:1

ER-100-A
 T-3-2
 M. J. FAIRFIELD, INC.
 1705 POST RD., FAIRFIELD, CONN.

DATE	SYM	REVISION RECORD	AUTH.	DR.	CHK.
		SEE ER-114	KJ		
		SEE ER-117			
6-22-68		SEE ER-169			FB
9-24-68		SEE ER-216			FB
6-30-68		SEE ER-353			FB
8-31-68		SEE ER-842			FB

RF. RANGE 3.5-12.5 MHz
 OSC RANGE 27-36 MHz
 SHIELDED ENCLOSURE

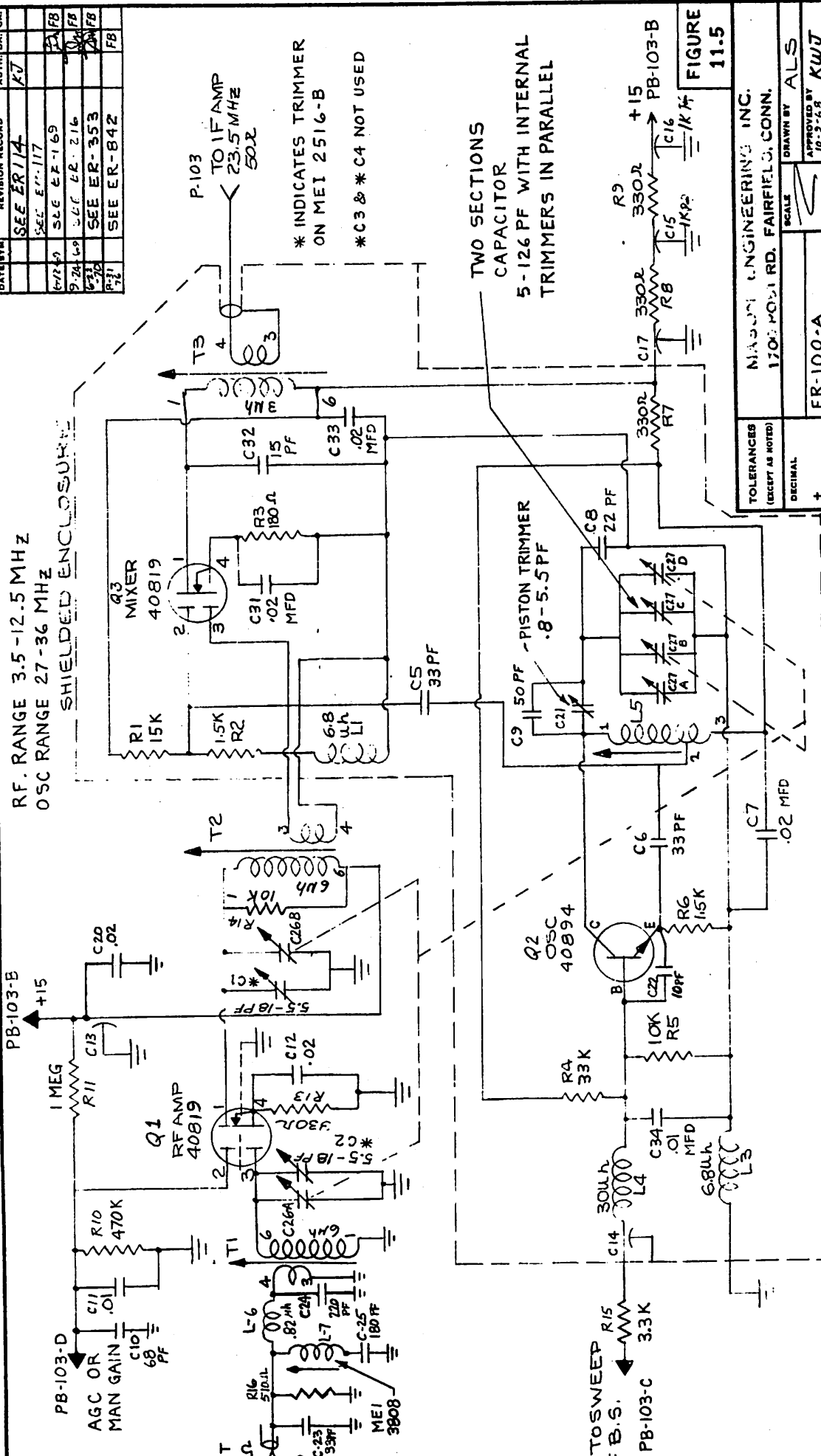

FIGURE 11.5

TOLERANCES (EXCEPT AS NOTED)	MAAGUI ENGINEERING INC. 1700 POWRI RD. FAIRFIELD, CONN.
DECIMAL	SCALE
FRACTIONAL	DRAWN BY ALS
ANGULAR	APPROVED BY KWT 10-3-68
USED ON	TITLE
1 30120-C	ER-100-A
	SCHEMATIC WIRING DIAGRAM
	IA 3-3
	DRAWING NUMBER
	DATE
	8-10-68
	DRAWING NUMBER
	SWD-4025-B
	ISSUE
	8

ALL FEED THRU'S 1500PF EXCEPT C15, C16 AT 1000PF
 ALL RESISTORS 1/4 W

DATE	REV	REVISION RECORD	AUTH	DR	CK
1/22		SEE ER-116			
3/10/49		SEE ER-159			
3/24/49		SEE ER-216			
5/19		SEE ER-253			
4/16		SEE ER-313			
5/10		SEE ER-384			
5/17		SEE ER-462			
5/17		SEE ER-581			
5/28		SEE ER-620			
9/1		SEE ER-842			

* INDICATES TRIMMER ON MEI 2516-B

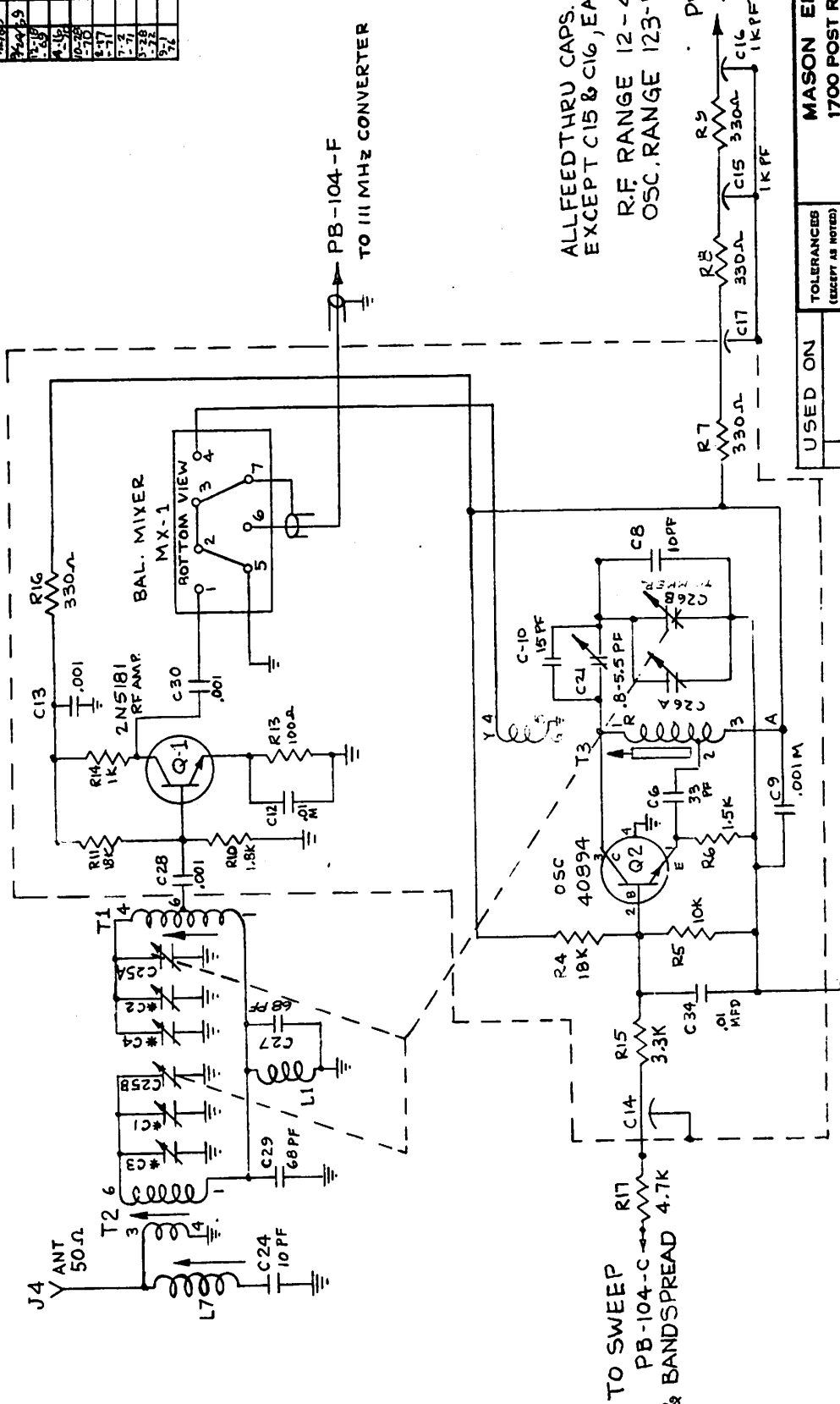

ALL FEEDTHRU CAPS. 1500 PF
EXCEPT C15 & C16, EACH 1000 PF
R.F. RANGE 12-43 MHz
OSC. RANGE 123-154 MHz

PB-104-B
+15V
C16 1K PF
C15 330Ω
R5
C17 330Ω
R7
C18 1K PF

FIGURE 11-6

USED ON		TOLERANCES (EXCEPT AS NOTED)		MASON ENGINEERING INC. 1700 POST RD. FAIRFIELD, CONN.	
		DECIMAL	±	SCALE	DRAWN BY S.P.M.
		FRACTIONAL	±		APPROVED BY
		ANGULAR	±	TITLE SCHEMATIC WIRING DIAGRAM TA3-4	
				DATE 4-20-70	DRAWING NUMBER SWD-4026-B
					ISSUE 11

ER-100-A

DATE	BY	REVISION	RECORD	AUTH	DR	CL
1-11-54		SEE ER-166				
1-16-59		SEE ER-248				
5-2-57		SEE ER-548				
1-7-57		SEE ER-776				

COPPER BOX

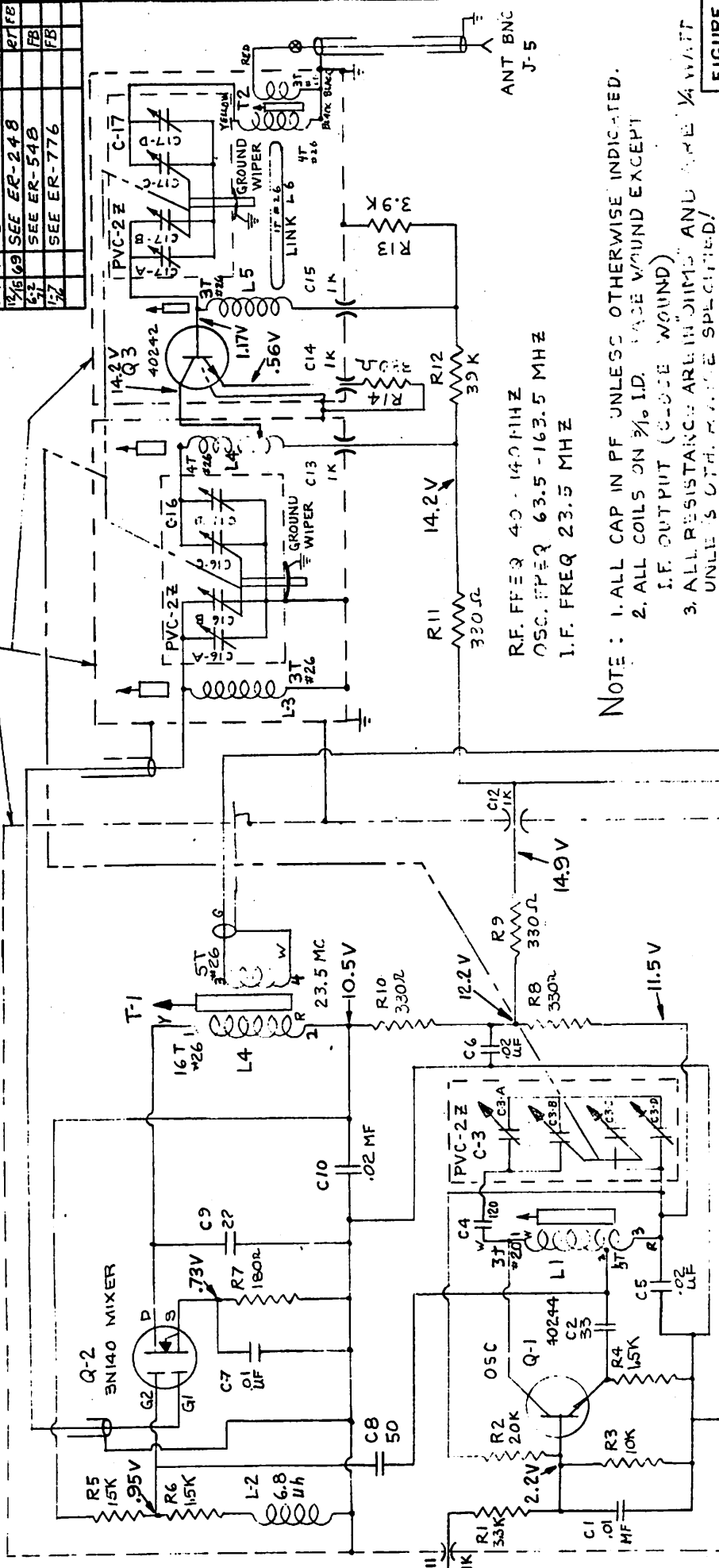

R.F. FREQ 40 - 14.0 MHz
 OSC. FREQ 63.5 - 163.5 MHz
 I.F. FREQ 23.5 MHz

NOTE: 1. ALL CAP IN PF UNLESS OTHERWISE INDICATED.
 2. ALL COILS ON 3/16 ID. CASE WOUND EXCEPT I.F. OUTPUT (CLOSE WOUND)
 3. ALL RESISTANCE ARE IN OHMS AND ARE 1/4 WATT UNLESS OTHERWISE SPECIFIED!

PC-4027

NOTE: 4. ALL VOLTAGE CHECKS MADE WITH 20,000 OHMS/VOLT METER

FIGURE 11-7

TOLERANCES (EXCEPT AS NOTED)		SCALE	DRAWN BY	APPROVED BY
DECIMAL	±		ALS/12	FLA/1
FRACTIONAL	±			
ANGULAR	±			

DATE	DRAWING NUMBER	ISSUE
6-12-68	SWD-4027-B	5

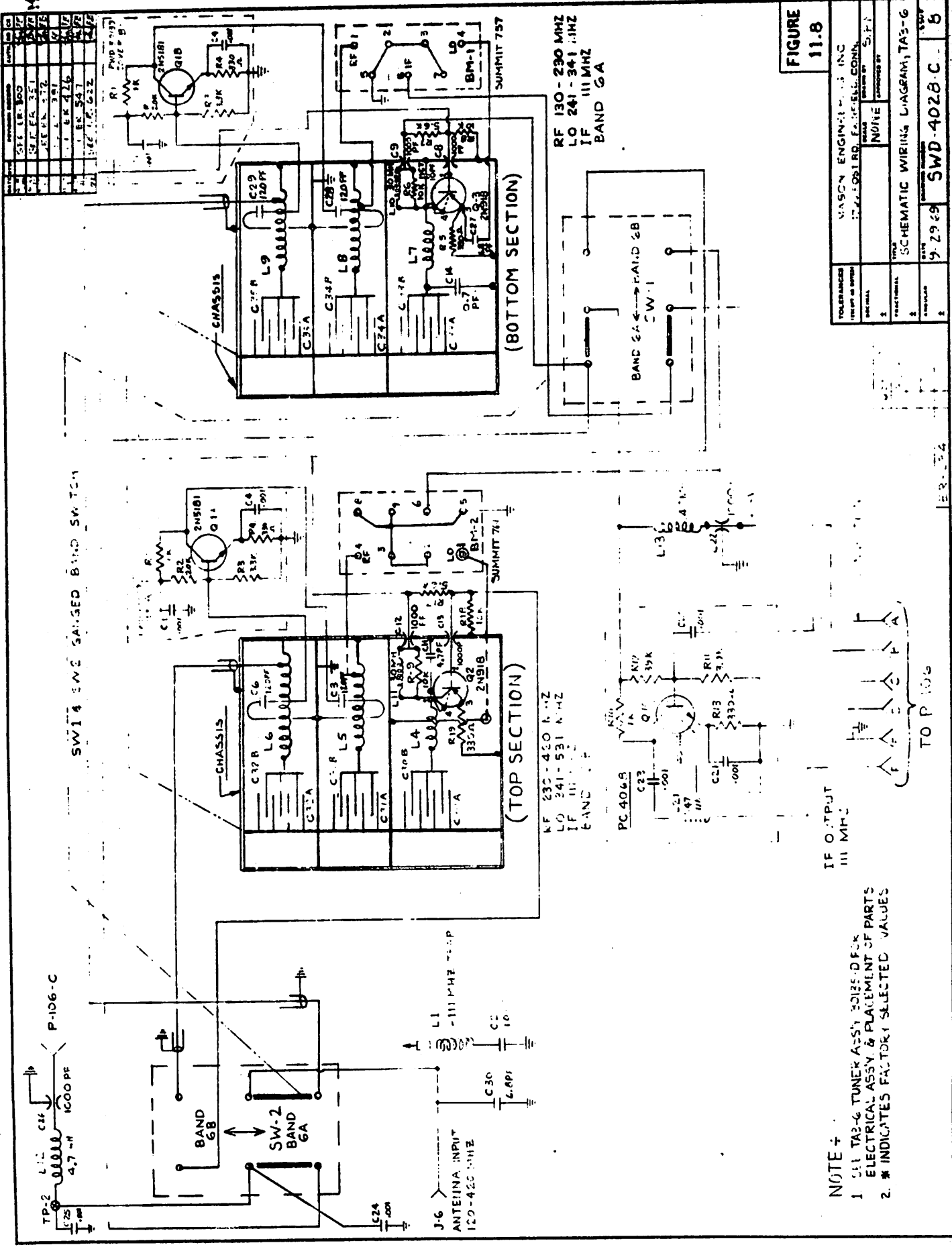

FIGURE 11.8

TOLERANCES (EXCEPT AS SHOWN)	RESISTORS	%.5
CAPACITORS	%.5	
WIRE GAUGE	NO. 18	
WIRE TYPE	SCHEMATIC WIRING DIAGRAM 1A3-G	
DATE	9-29-69	
DRAWN BY	SWD-4028-C	
CHECKED BY	5-F-1	
APPROVED BY		
PAGE NO.	8	

NOTE +
 1. SEE TR3-G TUNER ASSY 30185-DE-8X ELECTRICAL ASSY. & PLACEMENT OF PARTS
 2. * INDICATES FACTORY SELECTED VALUES

ER-34

TOP 106

NO.	REVISION	DATE	BY	CHKD.
1	SEE ER-210			
2	SEE ER-232			
3	SEE ER-232			
4	SEE ER-232			
5	SEE ER-232			
6	SEE ER-468			
7	SEE ER-468			
8	RTP			

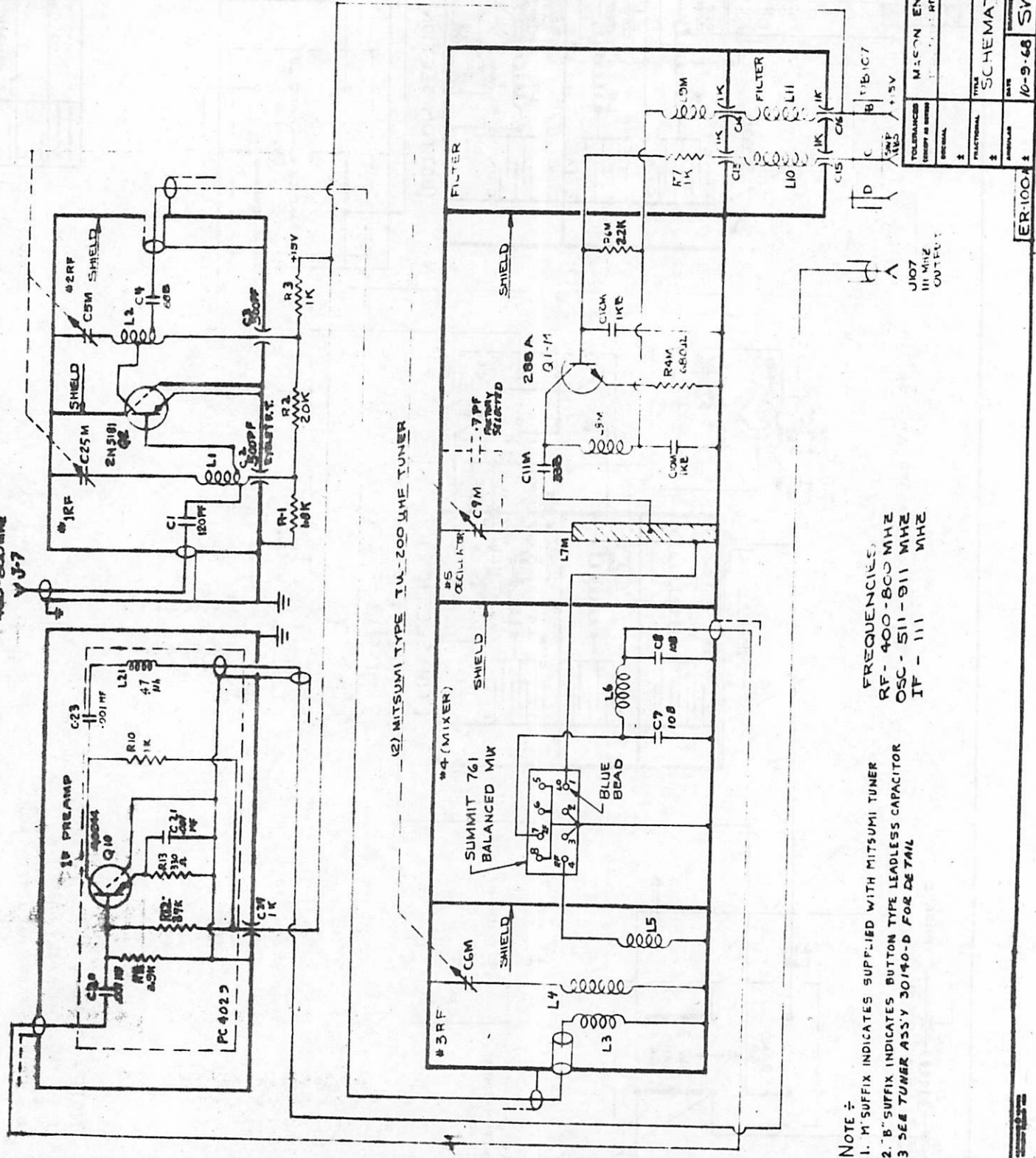

NOTE :-
 1. 'M' SUFFIX INDICATES SUPPLIED WITH MITSUMI TUNER
 2. 'B' SUFFIX INDICATES BUTTON TYPE LEADLESS CAPACITOR
 3. SEE TUNER ASSY 30140-D FOR DETAIL

FREQUENCIES
 RF - 400-800 MHZ
 OSC - 511-911 MHZ
 IF - 111

FIGURE 11.9

MIL-STD-883C	
TOLERANCES (EXCEPT AS NOTED)	RESISTORS: 1% (1%, 5%, 10%)
CONDENSATORS	10% (10%, 20%, 50%, 100%)
INDUCTORS	10% (10%, 20%, 50%, 100%)
TRANSISTORS	10% (10%, 20%, 50%, 100%)
DIODES	10% (10%, 20%, 50%, 100%)
VARIABLES	10% (10%, 20%, 50%, 100%)
RELAYS	10% (10%, 20%, 50%, 100%)
CONNECTORS	10% (10%, 20%, 50%, 100%)
WELDED JOINTS	10% (10%, 20%, 50%, 100%)
WELDING	10% (10%, 20%, 50%, 100%)
DRILLING	10% (10%, 20%, 50%, 100%)
MACHINING	10% (10%, 20%, 50%, 100%)
FINISHES	10% (10%, 20%, 50%, 100%)
PAINTS	10% (10%, 20%, 50%, 100%)
COATINGS	10% (10%, 20%, 50%, 100%)
ASSEMBLY	10% (10%, 20%, 50%, 100%)
TESTING	10% (10%, 20%, 50%, 100%)
REVISIONS	10% (10%, 20%, 50%, 100%)
DATE	10-9-68
REVISED	11/83
FIGURE NO.	11.9
PROJECT NO.	SWD-4046-C
REV.	8

ER1004

REV	DATE	BY	CHKD
1	10/10/54	WJ	WJ
2	11/11/54	WJ	WJ
3	11/11/54	WJ	WJ
4	11/11/54	WJ	WJ
5	11/11/54	WJ	WJ

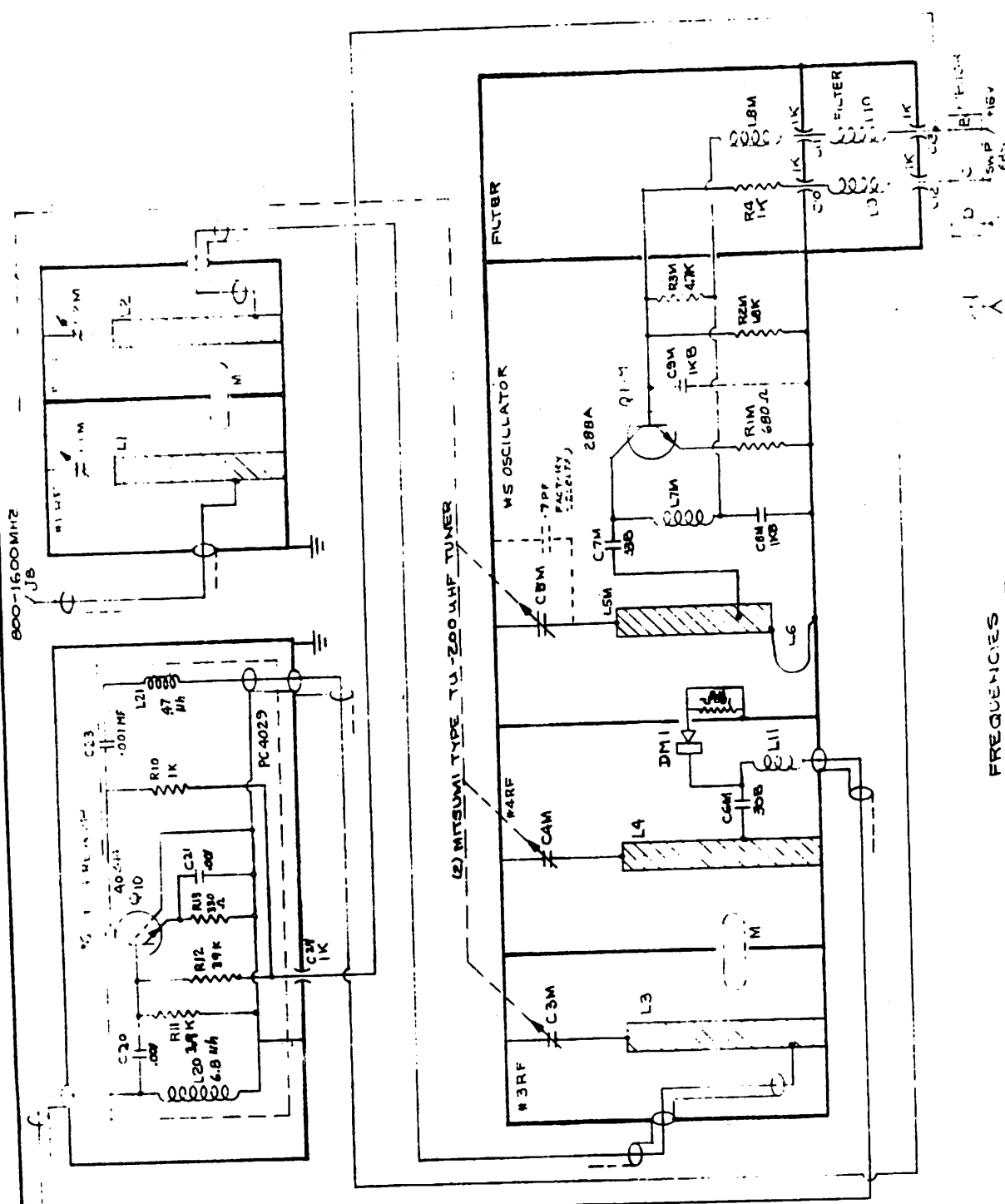

TOLERANCES UNLESS OTHERWISE SPECIFIED		SCALE	
RESISTORS	1%	RESISTORS	1%
CAPACITORS	5%	INDUCTORS	5%
DATE		DRAWING NUMBER	
11/11/54		100-11111-1	
DESIGNED BY		CHECKED BY	
WJ		WJ	
DRAWN BY		DATE	
WJ		11/11/54	
PROJECT		JOB NO.	
100-11111-1		100-11111-1	
SHEET NO.		OF SHEETS	
1		1	

FIGURE 11-10

MAS ENGINEERING INC.
1700 E. FAIRFIELD, COV.
SCALE 1:1

FREQUENCIES
RF - 800-1600 MHz
OSC B - 455-855 MHz
OSC F2 - 911-1711 MHz
IF - 111 MHz

NOTE -
1. MUFFIN INDICATED SUPPLIED WITH MITSUBISHI TUNER
2. B SUFFICI INDICATED BATTERY TYPE LEADS
3. SEE TUNER ASSY 30155-D FOR DETAIL

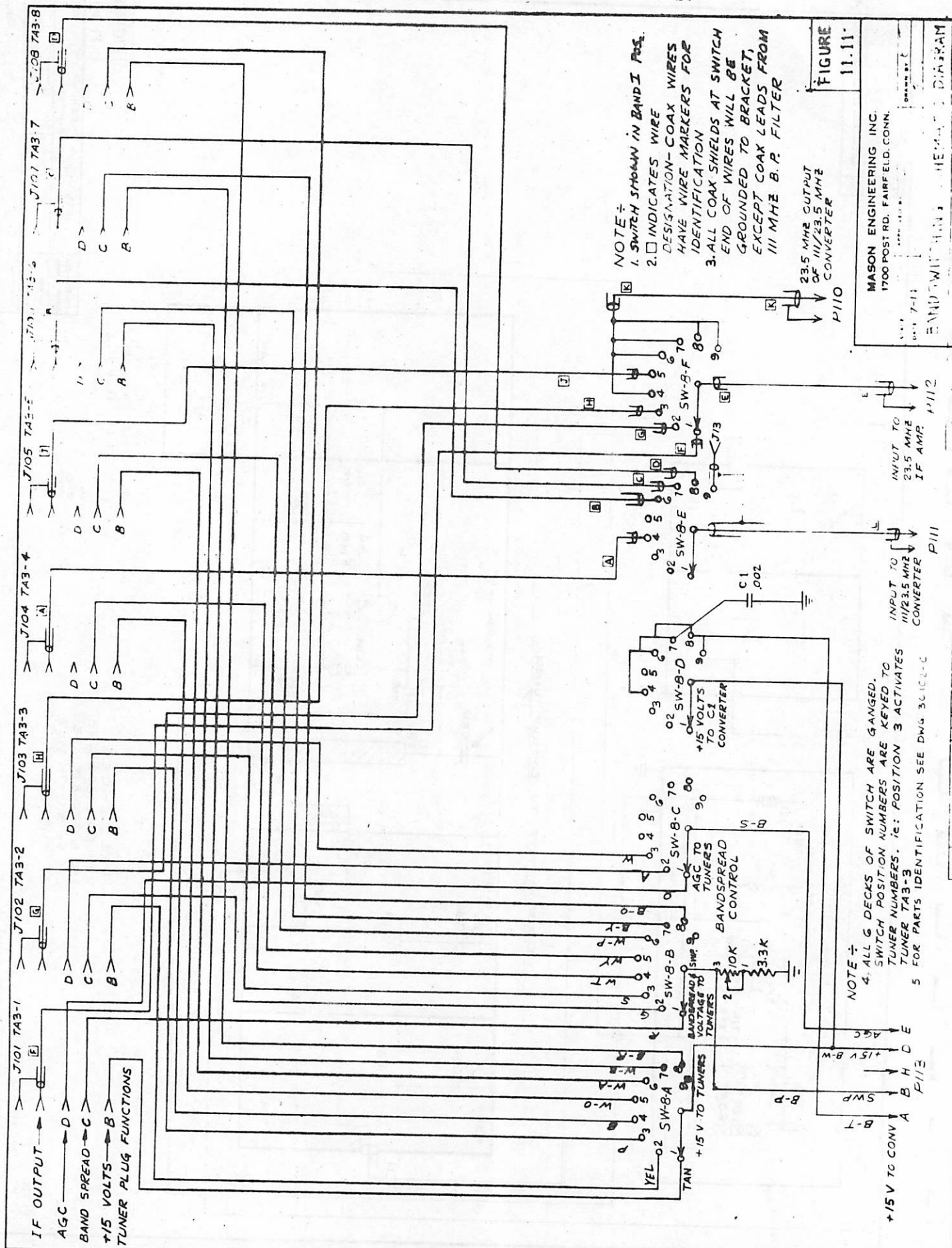

NOTE -
 1. SWITCH SHOWN IN BAND I POS.
 2. \square INDICATES WIRE DESIGNATION-COAX WIRES HAVE WIRE MARKERS FOR IDENTIFICATION
 3. ALL COAX SHIELDS AT SWITCH END OF WIRES WILL BE GROUNDED TO BRACKET, EXCEPT COAX LEADS FROM III Mhz B.P. FILTER

FIGURE 11.11

MASON ENGINEERING INC.
 1700 POST RD. FAIRFIELD, CONN.
 7-11

NOTE -
 4. ALL G. DECKS OF SWITCH ARE GANGED.
 5. SWITCH POSITION NUMBERS ARE KEYED TO TUNER NUMBERS. i.e. POSITION 3 ACTIVATES TUNER TAB-3
 5 FOR PARTS IDENTIFICATION SEE DWG 36102-C

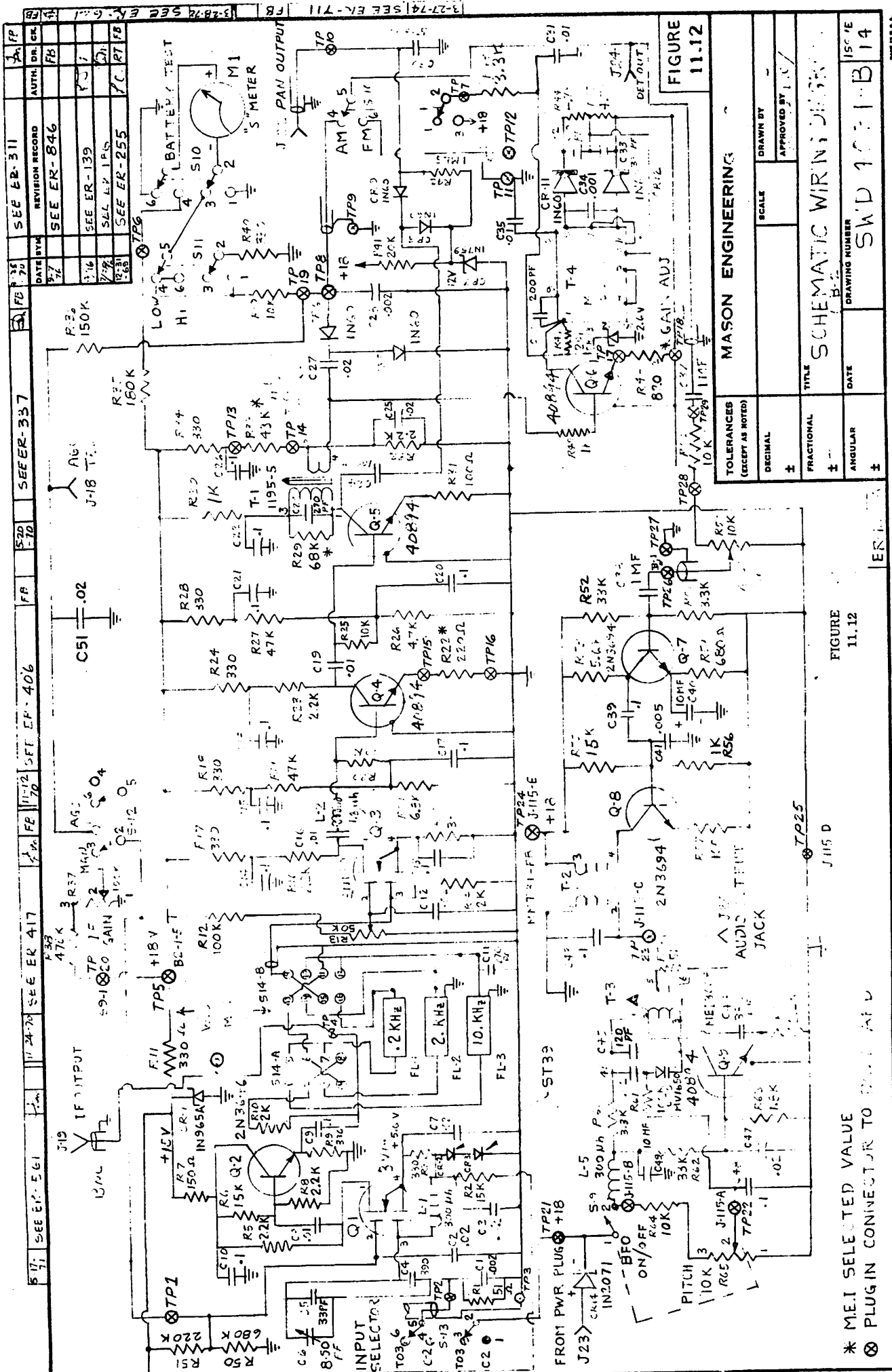

FIGURE 11.12

MASON ENGINEERING

TOLERANCES (EXCEPT AS NOTED)	SCALE	DRAWN BY
DECIMAL		APPROVED BY
FRACTIONAL		
ANGULAR		

TITLE SCHEMATIC WIRING DIAGRAM
 DRAWING NUMBER SWD 1001-B14
 DATE
 DATE

FIGURE 11.12

* M.E.I. SELECTED VALUE
 ⊗ PLUG IN CONNECTOR TO BOARD

DATE	BY	REVISION RECORD	AUTH	DE
11-17-53	W. H. W.	INITIAL DESIGN	W. H. W.	W. H. W.
11-18-53	W. H. W.	REVISED TO 11-18-53	W. H. W.	W. H. W.
11-19-53	W. H. W.	REVISED TO 11-19-53	W. H. W.	W. H. W.
11-20-53	W. H. W.	REVISED TO 11-20-53	W. H. W.	W. H. W.
11-21-53	W. H. W.	REVISED TO 11-21-53	W. H. W.	W. H. W.
11-22-53	W. H. W.	REVISED TO 11-22-53	W. H. W.	W. H. W.
11-23-53	W. H. W.	REVISED TO 11-23-53	W. H. W.	W. H. W.
11-24-53	W. H. W.	REVISED TO 11-24-53	W. H. W.	W. H. W.
11-25-53	W. H. W.	REVISED TO 11-25-53	W. H. W.	W. H. W.
11-26-53	W. H. W.	REVISED TO 11-26-53	W. H. W.	W. H. W.
11-27-53	W. H. W.	REVISED TO 11-27-53	W. H. W.	W. H. W.
11-28-53	W. H. W.	REVISED TO 11-28-53	W. H. W.	W. H. W.
11-29-53	W. H. W.	REVISED TO 11-29-53	W. H. W.	W. H. W.
11-30-53	W. H. W.	REVISED TO 11-30-53	W. H. W.	W. H. W.

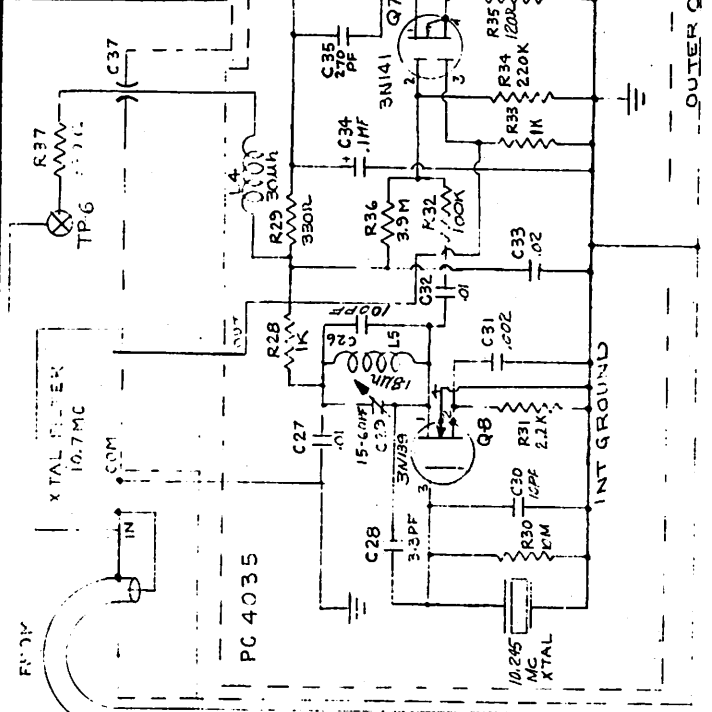

SWD 4035
C2-H

FT - FLEETING CAP 1000PF
SO - STABLE CAP 1000PF
ALL CAPS IN M UNLESS OTHERWISE NOTED
* CAP MUST BE SELECTED TO IN A HIGH K
MATERIAL TO BE USED ON SWD 4035

FIGURE 11.13

TOLERANCES EXCEPT AS NOTED	SCALE	DRAWN BY	APPROVED BY
DECIMAL			

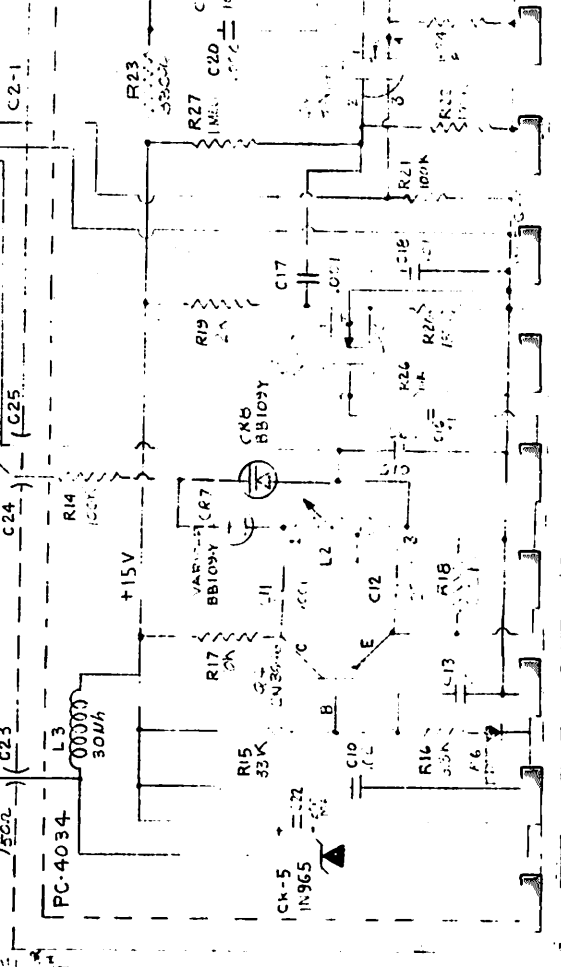
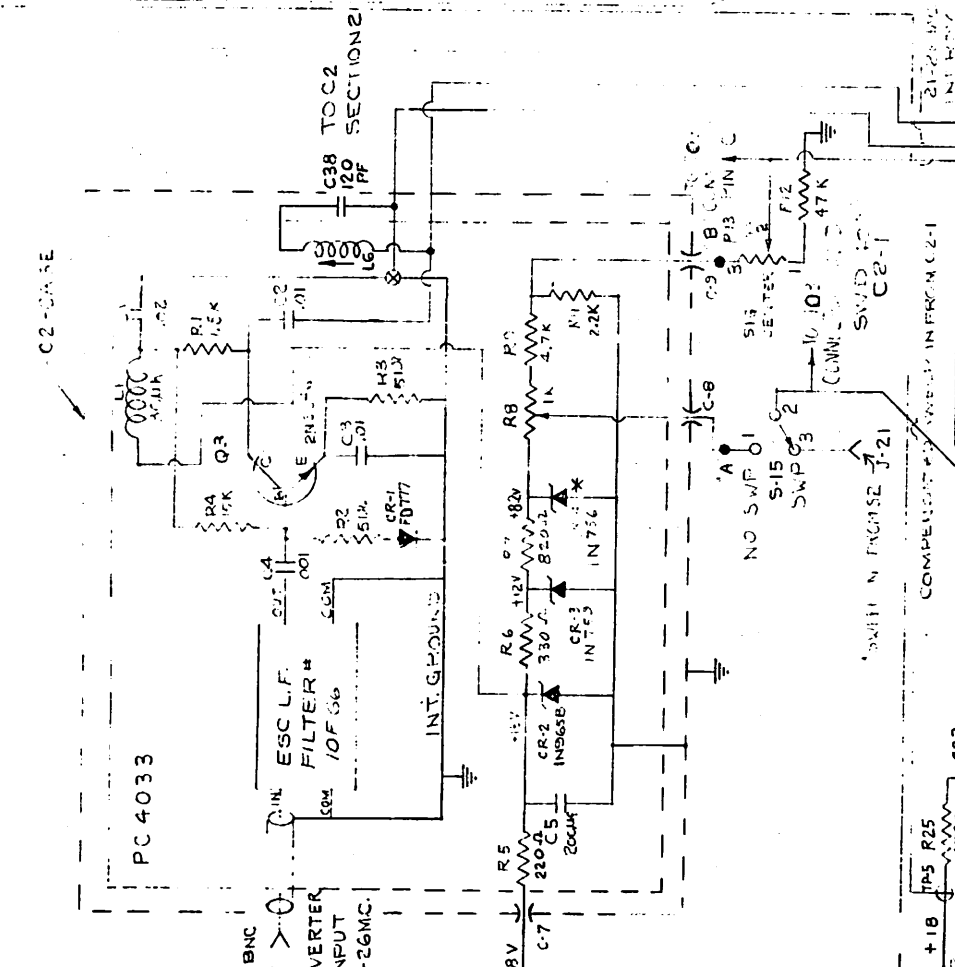

TOLERANCES EXCEPT AS NOTED	SCALE	DRAWN BY	APPROVED BY
DECIMAL			

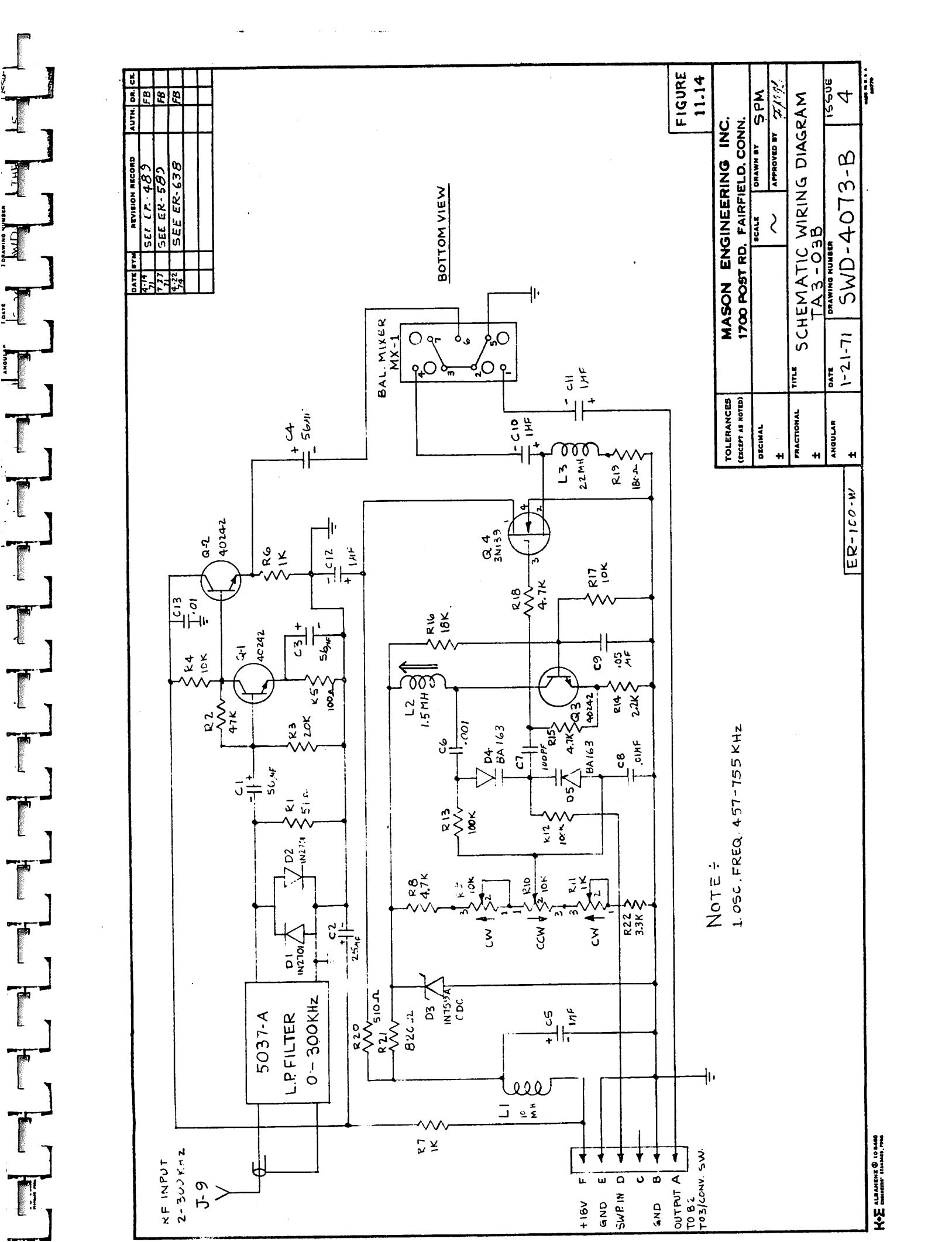

DATE	BY	REVISION RECORD	AUTH.	DR.	CL.
7/17		SEE L.P. 483			FB
7/17		SEE ER-583			FB
9/22		SEE ER-638			FB

BOTTOM VIEW

FIGURE 11.14

TOLERANCES (EXCEPT AS NOTED)	MASON ENGINEERING INC. 1700 POST RD., FAIRFIELD, CONN.	
DECIMAL	SCALE	DRAWN BY SPM
FRACTIONAL	APPROVED BY	
ANGULAR	TITLE	DATE
	SCHEMATIC WIRING DIAGRAM TA3-03B	1-21-71
	DRAWING NUMBER	ISSUE
	SWD-4073-B	4

NOTE: 1. OSC. FREQ. 457-755 KHZ

ER-100-W

REV	DESCRIPTION
1	REV. BR-26-
2	REV. C-41D
3	SEE ER-633
4	SEE ER-766

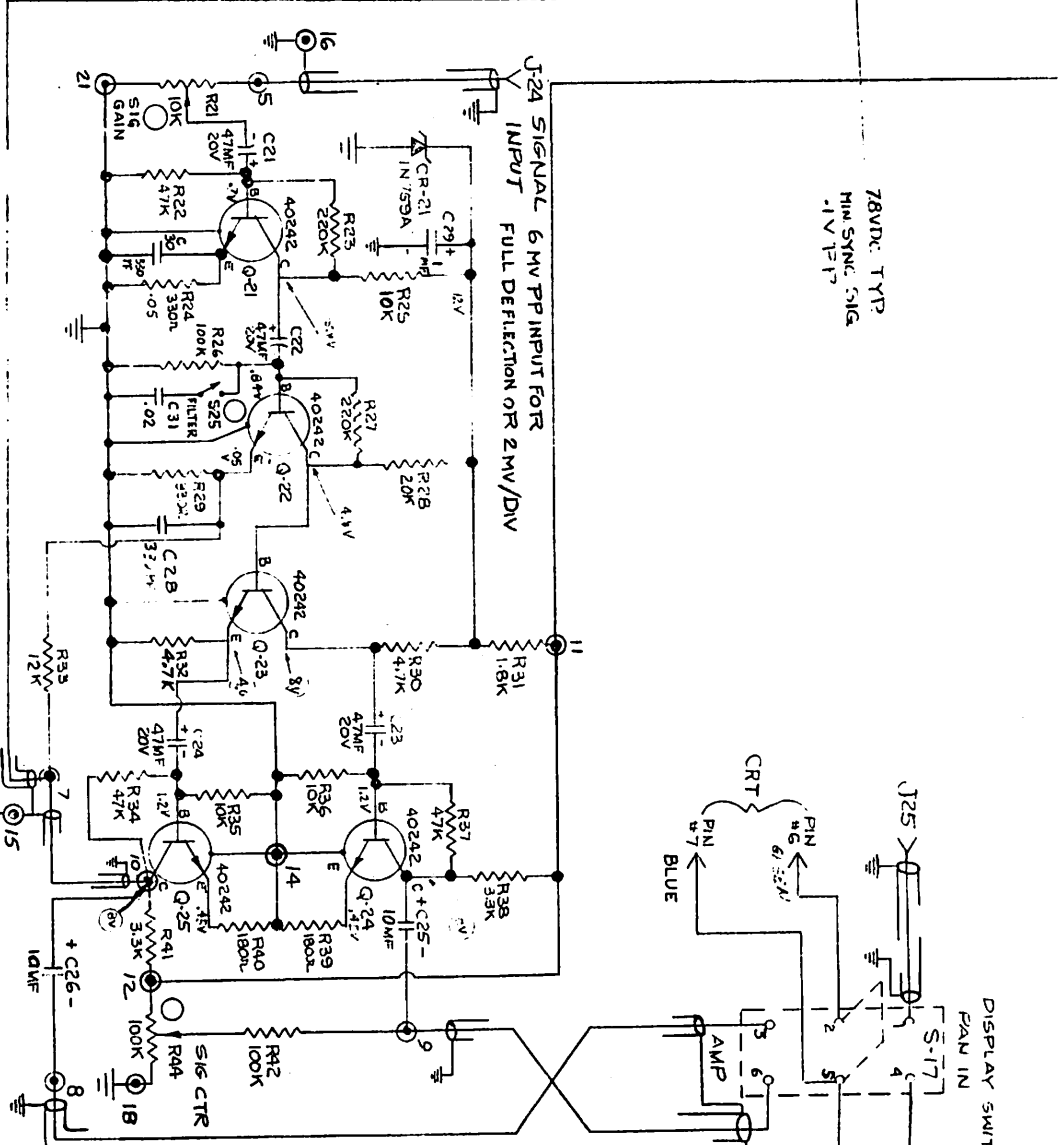
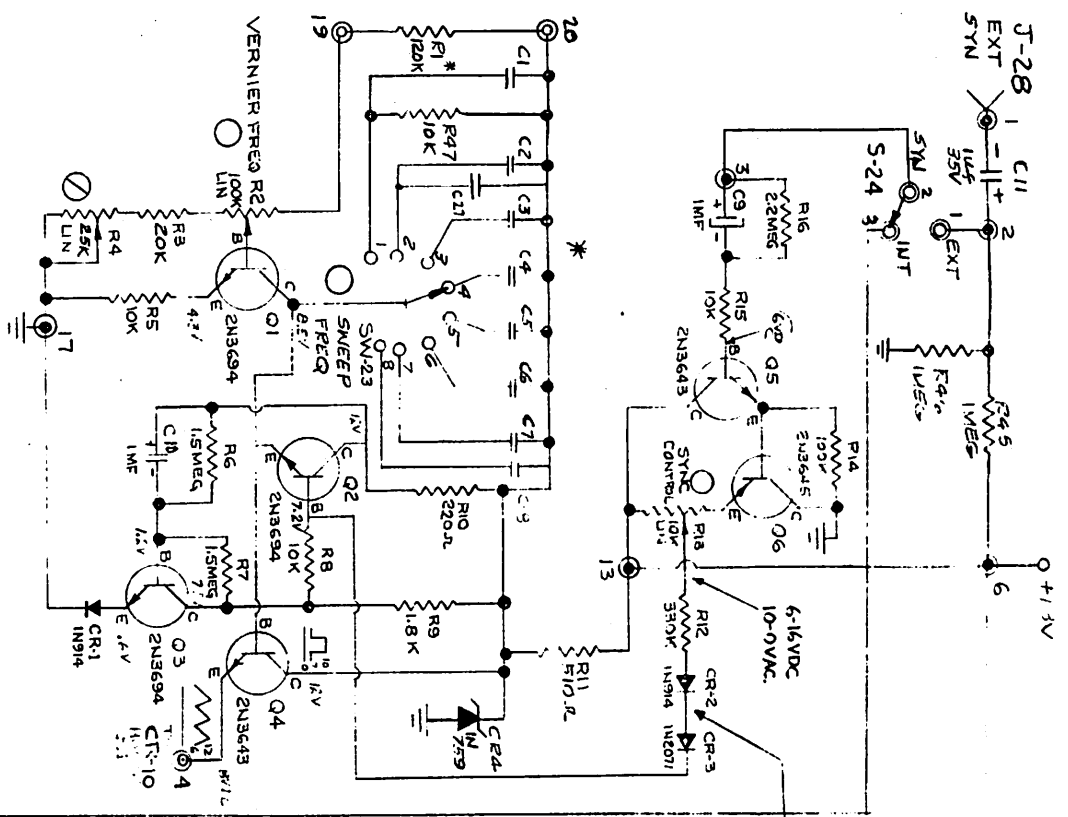

* C VALUES	PERIOD	SWEEP FREQ
C1 10MF	MANUAL	5 - 1 Hz
C27 10MF	} 20 - 100 MS	25 - 5 Hz
C2 10MF		
C3 3.3MF		
C4 .67MF	4 - 20MS	143 - 25 Hz
C5 .15MF	7 - 4 MS	740 - 143 Hz
C6 .022 MF	135 - 700 US	3.3 - 74 KHz
C7 4700 MMF	30 - 135 US	16.6 - 3.3 KHz
C8 1000 MMF	6 - 30 US	66 - 16.6 KHz

- ⊙ TERMINAL ON CIRCUIT BD. (COPPER SIDE)
- EXTERNAL COMPONENTS
- ⊖ SCHEMATIC SIDE OF BOARD
- ⊙ TERMINAL ON CIRCUIT BD. (COMPONENT SIDE)
- * FACTORY ADJUSTED, VALUE MAY BE DIFFERENT FOR EACH UNIT

ER-100-A	1
TOLERANCES (EXCEPT AS NOTED)	
FRACTIONAL	
DECIMAL	
SCHEMATIC WIRING DIAG VERTICAL AMP S-3	
DATE	11-12-68
DRAWING NUMBER	SWD 4038-C

DATE	BY	REVISION	RECORD	AUTH	CHK
10-22-68	ER	162			
		SEE ER-262			
		SEE ER-400			
		SEE ER-423			
		SEE ER-523			

S22 SWITCH POSITION	SWEEP WIDTH
1	5 MHz
2	12 MHz
3	300 KHz
4	60 KHz
5	10 KHz
6	3 KHz

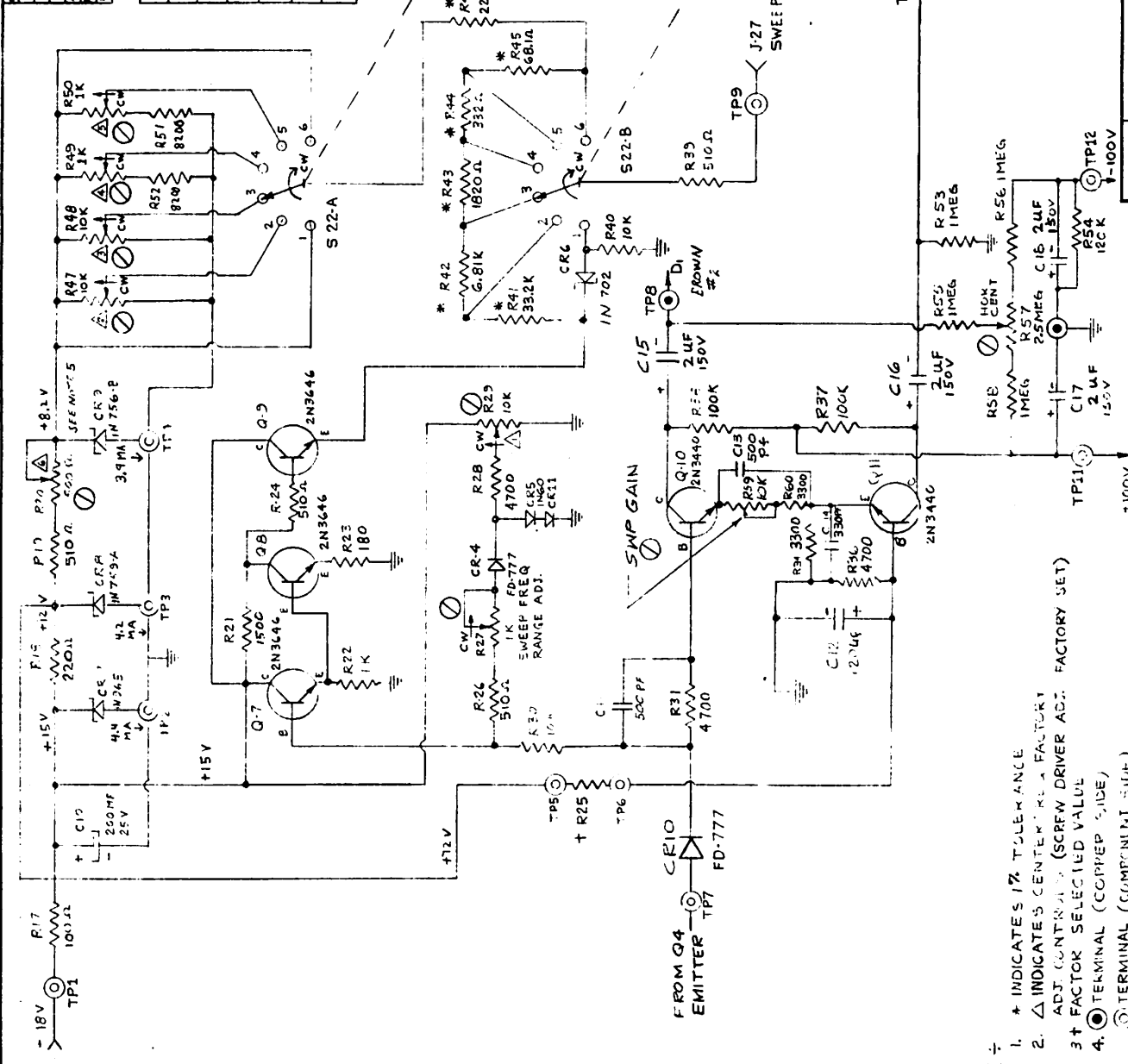

SWEEP WIDTH ALIGNMENT PROCEDURE	
1	ADJUST R47 FOR SWEEP WIDTH WITH CENTERING
2	ADJUST R49 FOR 3 MHz CENTERING
3	ADJUST R49 FOR 500 KHz CENTERING
4	ADJUST R49 FOR 60 KHz CENTERING
5	ADJUST R50 FOR 10 KHz CENTERING

- NOTE ÷
- * INDICATES 1% TOLERANCE
 - △ INDICATES CENTER RES. FACTORY ADJ. CONTROL (SCREW DRIVER ADJ. FACTORY SET)
 - † FACTOR SELECTED VALUE
 - ⊙ TERMINAL (COMPONENT SIDE)
 - ⊙ TERMINAL (COMPONENT SIDE)
 - ⊙ EXTERNAL CONTROL
 - ⊙ SCREW DRIVER ADJUSTED CONTROL
 - ⊙ CR3 MIN. MAX. ADJUSTABLE RANGE CONTROL

FIGURE 11.16

MASON ENGINEERING INC.
1700 POST RD. FAIRFIELD, CONN.

DESIGNED BY: [Signature]
CHECKED BY: [Signature]
APPROVED BY: [Signature]

TOLERANCES (EXCEPT AS NOTED)
RESISTORS: ±%
CAPACITORS: ±%
DIMENSIONS: ±

FUNCTIONAL: ±
MECHANICAL: ±
ELECTRICAL: ±

DATE: 10-22-68
DRAWING NUMBER: SWD-4039-C
SCALE: [Blank]

ER-100-A

DATE	SYM	REVISION RECORD	AUTH.	DR. CC.
11/1		SEE ER-120	KJ	
11/2		SEE ER-151	KL	
11/3		SEE ER-251	RT/PB	
11/4		SEE ER-262	RT/PB	
11/5		SEE ER-489	RT/PB	
11/6		SEE ER-726	RT/PB	

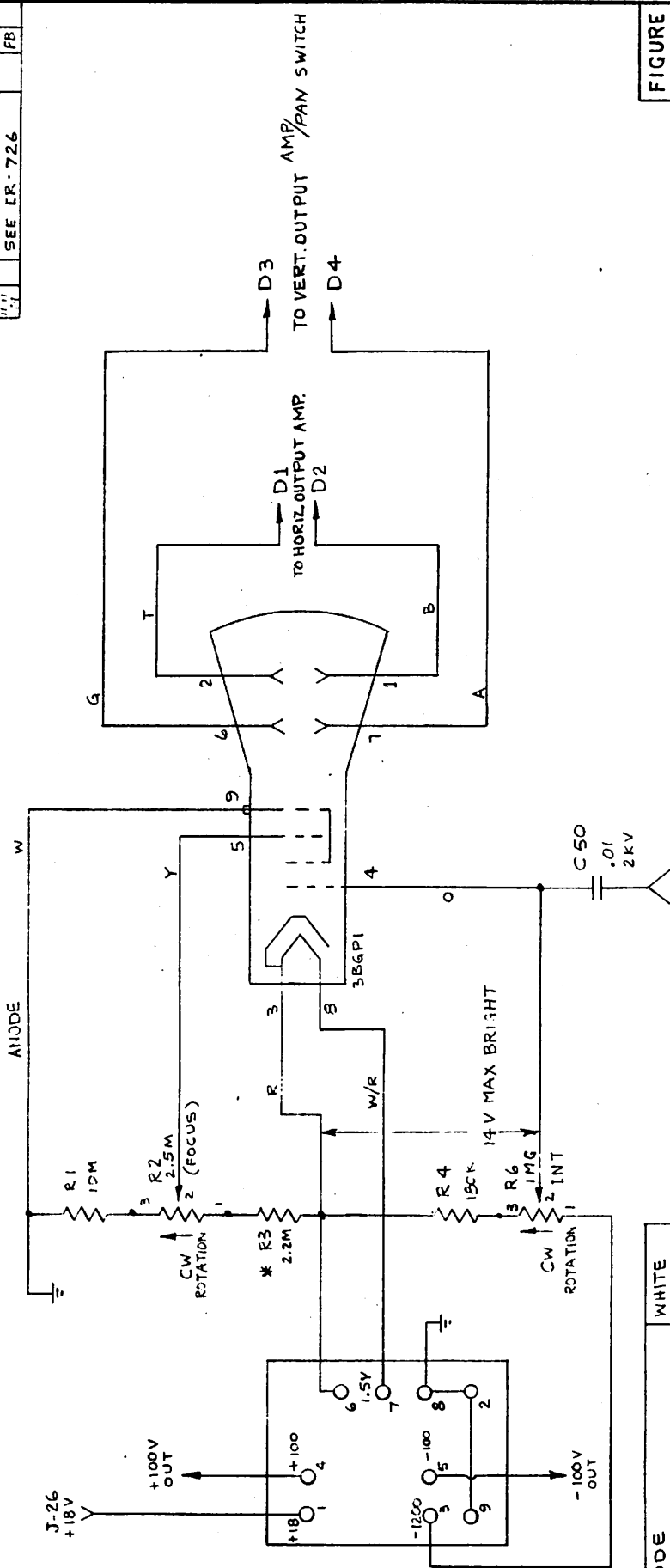

9	ANODE	WHITE
8	FILAMENT	WHITE/RED
7	VERTICAL PLATE	AZURE
6	VERTICAL PLATE	GREEN
5	GRID (FOCUS)	YELLOW
4	GRID (INTENSITY)	ORANGE
3	CATHODE & FILAMENT	RED
2	HORIZONTAL PLATE	TAN
1	HORIZONTAL PLATE	BLACK
NO.	FUNCTION (CRT)	COLOR

NOTE:
 1 FOR PARTS LIST SEE DWG. 30310-D
 2. * FACTOR ADJUST FOR FOCUS

J-29
 Z' AXIS INPUT

FIGURE
 11-17

TOLERANCES (EXCEPT AS NOTED)	SCALE	DRAWN BY	APPROVED BY
DECIMAL ± ~	~	S.P.M.	FLP
FRACTIONAL ± ~			
ANGULAR ± ~			
TITLE	DATE	DRAWING NUMBER	ISSUE
MASON ENGINEERING INC. 1700 POST RD, FAIRFIELD, CONN.	7-1-68	SWD-4042-B	7

ER-100-A

DATE	SYM	REVISION RECORD	AUTH.	DR.	CL.
12-29-71		SEE ER-771			R7

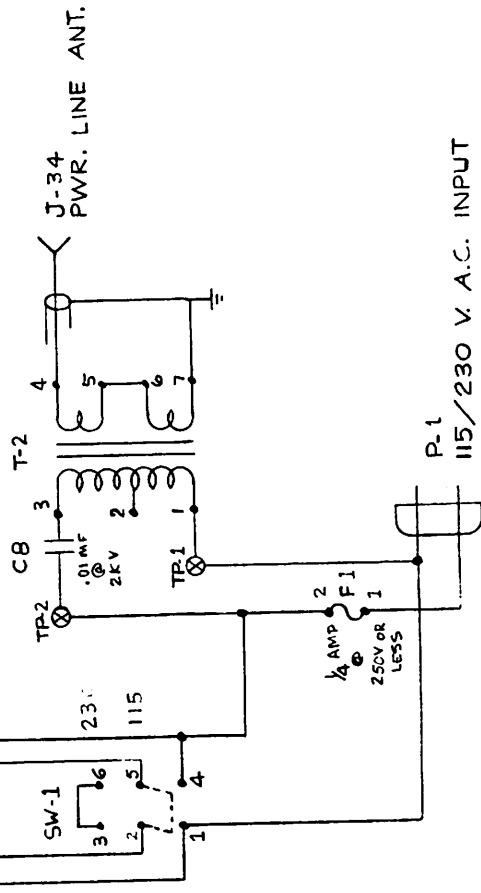
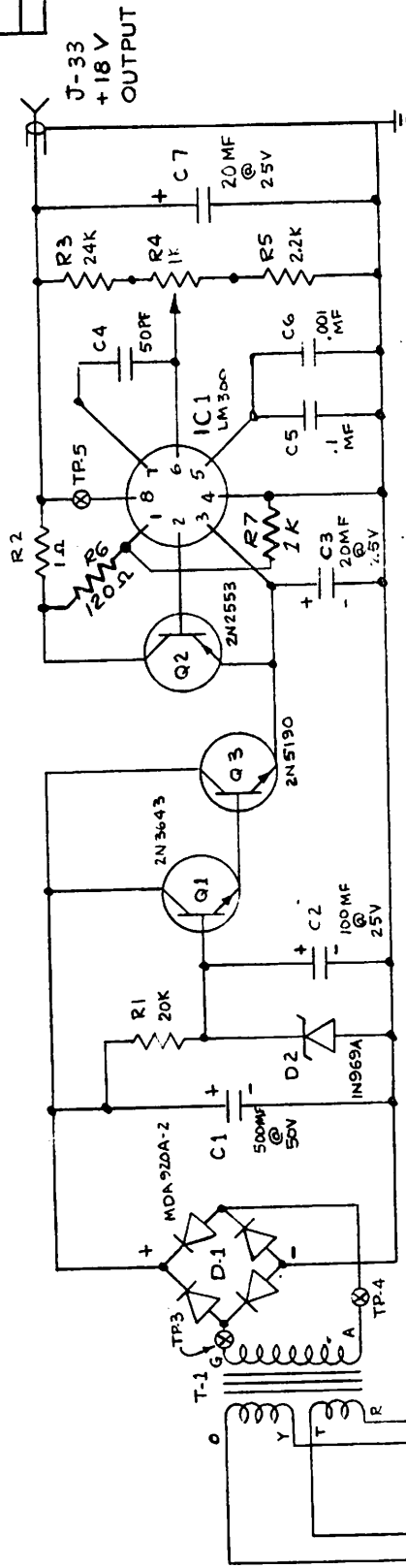

FIGURE 11.18

USED ON	TOLERANCES (EXCEPT AS NOTED)	SCALE	DRAWN BY
	DECIMAL		S.P.M.
	FRACTIONAL		APPROVED BY: <i>FF</i>
	ANGULAR		

MASON ENGINEERING INC. 1700 FOST RD. FAIRFIELD, CONN.	
TITLE	SCHEMATIC WIRING DIAG. PS-10
DATE	3-5-71
DRAWING NUMBER	SWD-4074-B
ISSUE	2

ER-100-X

DATE	SYMBOL	REVISION RECORD	AUTH.	DR.	CK.
11-17-70	44	SEE EK-726			FB
11-18-70	45	SEE ER-770			RT

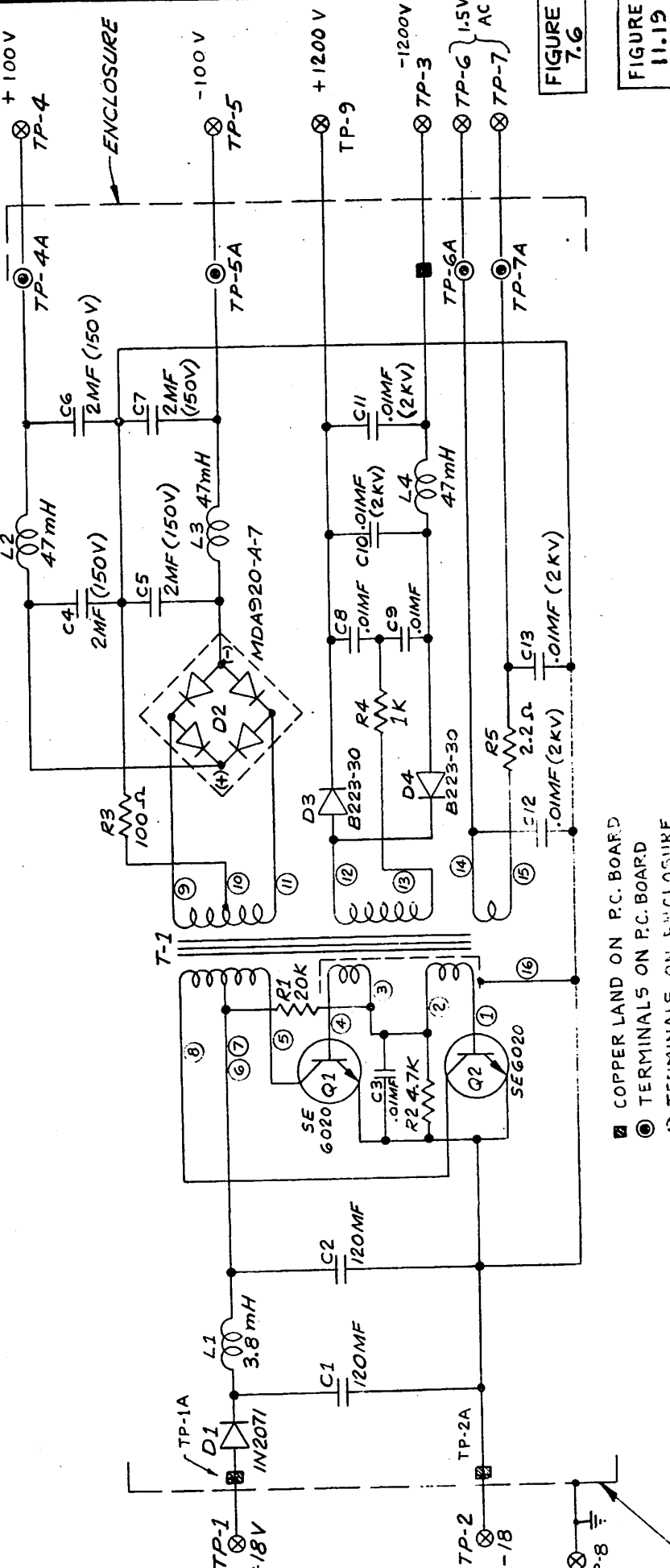

USED ON	TOLERANCES (EXCEPT AS NOTED)	SCALE	DRAWN BY
			PHF
	DECIMAL		APPROVED BY
	±		PHB
	FRACTIONAL		
	±		
	ANGULAR		
	±		

MASON ENGINEERING INC. 1700 POST RD. FAIRFIELD, CONN.	
TITLE	SCHEMATIC WIRING DIAG., H.V. CONVERTER
DATE	3-16-71
DRAWING NUMBER	SWD-4077-B
ISSUE	3

- ⊠ COPPER LAND ON P.C. BOARD
- ⊙ TERMINALS ON P.C. BOARD
- ⊗ TERMINALS ON ENCLOSURE

FIGURE 7.6

FIGURE 11.19

ER-100-Y

REV.	DATE	BY	CHKD.
1	5-3-71
2	5-3-71

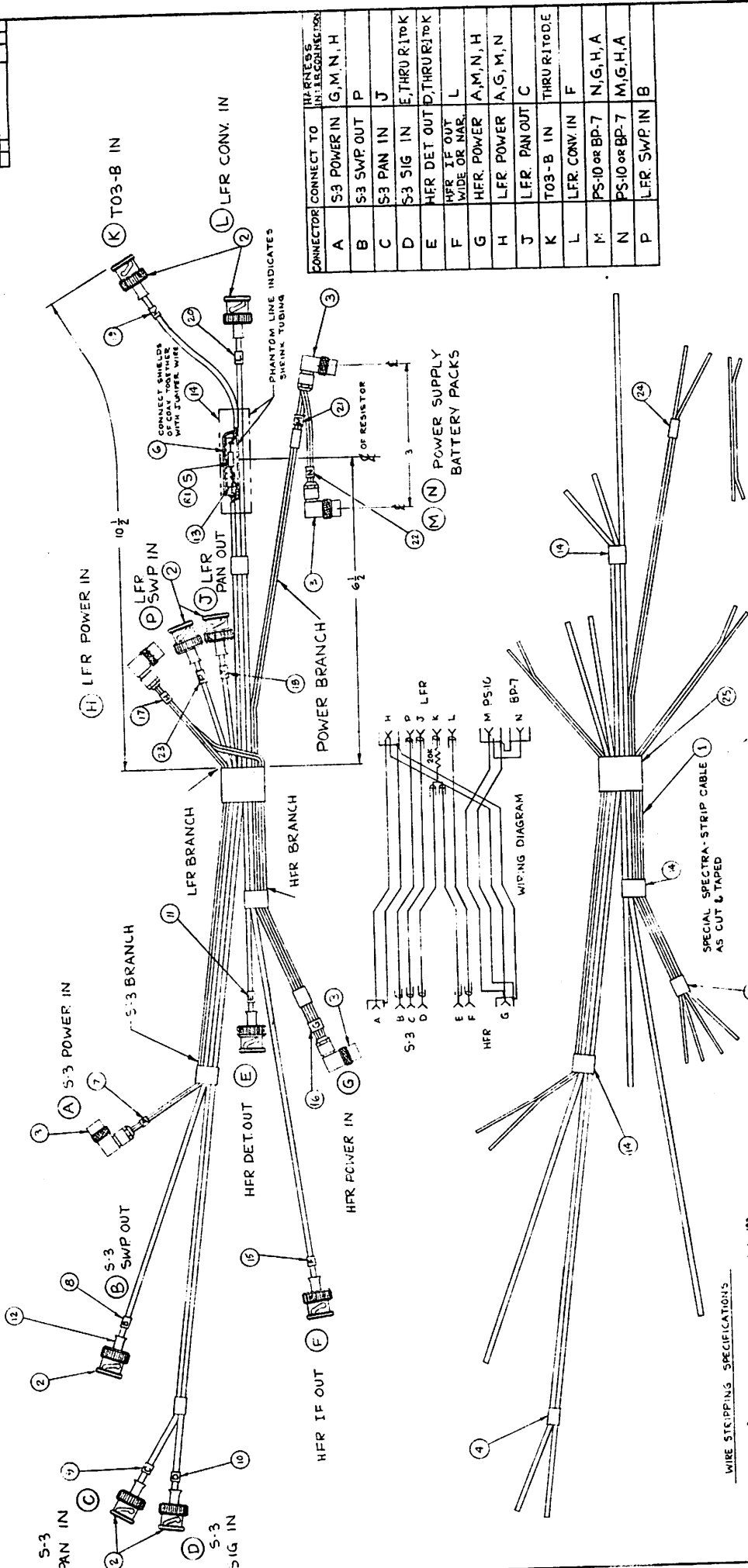

CONNECTOR	CONNECT TO	WIRE SIZE	INSULATION
A	S-3 POWER IN	G, M, N, H	
B	S-3 SWP OUT	P	
C	S-3 PAN IN	J	
D	S-3 SIG IN	E, THRU R, TP, K	
E	HFR DET OUT	D, THRU R, TP, K	
F	HFR IF OUT	L	
G	HFR POWER	A, M, N, H	
H	LFR POWER	A, G, M, N	
J	LFR PAN OUT	C	
K	T03-B IN	THRU R, TP, D, E	
L	LFR CONV IN	F	
M	PS-10 or BP-7	N, G, H, A	
N	PS-10 or BP-7	M, G, H, A	
P	LFR SWP IN	B	

NOTE -
1. USE THIS DRAWING AS A TEMPLATE FOR CUTTING WIRES
TO THEIR PROPER LENGTHS.

FIGURE 12.1

USED ON	1130730-A
REVISION	1.005
DATE	5-3-71
BY	6811-D
CHKD.	3

1	24137-A	TUBING, SHRINKABLE (S-14)	1/8"
2	24137-A	TUBING, SHRINKABLE (S-14)	1/8"
3	24137-A	WIRE MARKER (A)	
4	24137-A	WIRE MARKER (A)	
5	24137-A	WIRE MARKER (A)	
6	24137-A	WIRE MARKER (A)	
7	24137-A	WIRE MARKER (A)	
8	24137-A	WIRE MARKER (A)	
9	24137-A	WIRE MARKER (A)	
10	24137-A	WIRE MARKER (A)	
11	24137-A	WIRE MARKER (A)	
12	24137-A	WIRE MARKER (A)	
13	24137-A	WIRE MARKER (A)	
14	24137-A	WIRE MARKER (A)	
15	24137-A	WIRE MARKER (A)	
16	24137-A	WIRE MARKER (A)	
17	24137-A	WIRE MARKER (A)	
18	24137-A	WIRE MARKER (A)	
19	24137-A	WIRE MARKER (A)	
20	24137-A	WIRE MARKER (A)	
21	24137-A	WIRE MARKER (A)	
22	24137-A	WIRE MARKER (A)	
23	24137-A	WIRE MARKER (A)	
24	24137-A	WIRE MARKER (A)	
25	24137-A	WIRE MARKER (A)	
26	24137-A	WIRE MARKER (A)	
27	24137-A	WIRE MARKER (A)	
28	24137-A	WIRE MARKER (A)	
29	24137-A	WIRE MARKER (A)	
30	24137-A	WIRE MARKER (A)	
31	24137-A	WIRE MARKER (A)	
32	24137-A	WIRE MARKER (A)	
33	24137-A	WIRE MARKER (A)	
34	24137-A	WIRE MARKER (A)	
35	24137-A	WIRE MARKER (A)	
36	24137-A	WIRE MARKER (A)	
37	24137-A	WIRE MARKER (A)	
38	24137-A	WIRE MARKER (A)	
39	24137-A	WIRE MARKER (A)	
40	24137-A	WIRE MARKER (A)	
41	24137-A	WIRE MARKER (A)	
42	24137-A	WIRE MARKER (A)	
43	24137-A	WIRE MARKER (A)	
44	24137-A	WIRE MARKER (A)	
45	24137-A	WIRE MARKER (A)	
46	24137-A	WIRE MARKER (A)	
47	24137-A	WIRE MARKER (A)	
48	24137-A	WIRE MARKER (A)	
49	24137-A	WIRE MARKER (A)	
50	24137-A	WIRE MARKER (A)	

1	24137-A	TUBING, SHRINKABLE (S-14)	1/8"
2	24137-A	TUBING, SHRINKABLE (S-14)	1/8"
3	24137-A	WIRE MARKER (A)	
4	24137-A	WIRE MARKER (A)	
5	24137-A	WIRE MARKER (A)	
6	24137-A	WIRE MARKER (A)	
7	24137-A	WIRE MARKER (A)	
8	24137-A	WIRE MARKER (A)	
9	24137-A	WIRE MARKER (A)	
10	24137-A	WIRE MARKER (A)	
11	24137-A	WIRE MARKER (A)	
12	24137-A	WIRE MARKER (A)	
13	24137-A	WIRE MARKER (A)	
14	24137-A	WIRE MARKER (A)	
15	24137-A	WIRE MARKER (A)	
16	24137-A	WIRE MARKER (A)	
17	24137-A	WIRE MARKER (A)	
18	24137-A	WIRE MARKER (A)	
19	24137-A	WIRE MARKER (A)	
20	24137-A	WIRE MARKER (A)	
21	24137-A	WIRE MARKER (A)	
22	24137-A	WIRE MARKER (A)	
23	24137-A	WIRE MARKER (A)	
24	24137-A	WIRE MARKER (A)	
25	24137-A	WIRE MARKER (A)	
26	24137-A	WIRE MARKER (A)	
27	24137-A	WIRE MARKER (A)	
28	24137-A	WIRE MARKER (A)	
29	24137-A	WIRE MARKER (A)	
30	24137-A	WIRE MARKER (A)	
31	24137-A	WIRE MARKER (A)	
32	24137-A	WIRE MARKER (A)	
33	24137-A	WIRE MARKER (A)	
34	24137-A	WIRE MARKER (A)	
35	24137-A	WIRE MARKER (A)	
36	24137-A	WIRE MARKER (A)	
37	24137-A	WIRE MARKER (A)	
38	24137-A	WIRE MARKER (A)	
39	24137-A	WIRE MARKER (A)	
40	24137-A	WIRE MARKER (A)	
41	24137-A	WIRE MARKER (A)	
42	24137-A	WIRE MARKER (A)	
43	24137-A	WIRE MARKER (A)	
44	24137-A	WIRE MARKER (A)	
45	24137-A	WIRE MARKER (A)	
46	24137-A	WIRE MARKER (A)	
47	24137-A	WIRE MARKER (A)	
48	24137-A	WIRE MARKER (A)	
49	24137-A	WIRE MARKER (A)	
50	24137-A	WIRE MARKER (A)	

WIRE STRIPPING SPECIFICATIONS

FLAIR OUT SHIELD OF COAX FOR ACCESS TO CENTER CONDUCTOR

TIP STRIPPING FOR ALL 20 GAUGE WIRES

TOP MOUNTING SURFACE FOR TUNERS & B1 BASIC UNIT

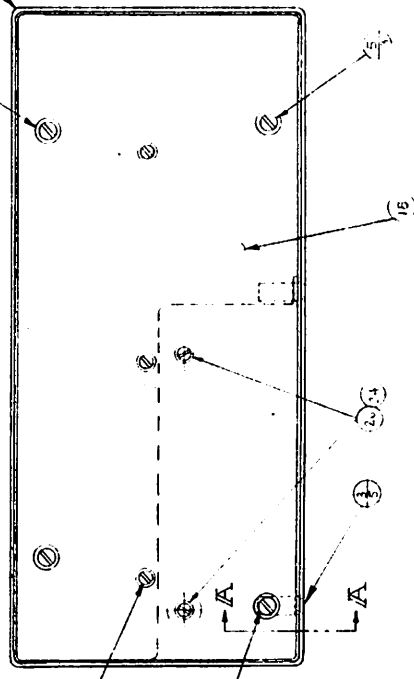
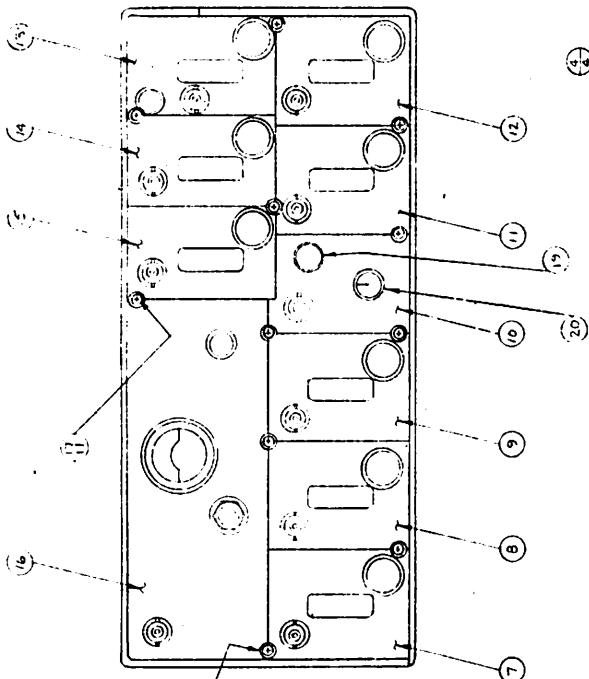
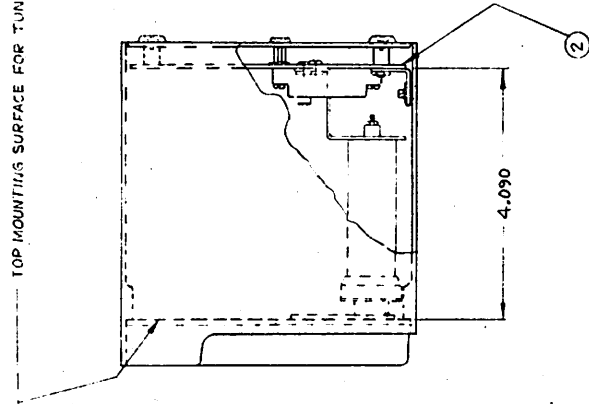

NOTE +
LONG END OF BRACKET (ITEM #21)
MOUNTS ON BOTTOM PLATE

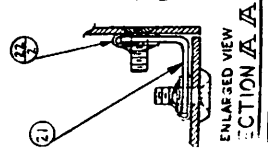

BOTTOM VIEW

QTY	PART NO.	PART NAME
1	19052-D	CASE - H.E.R. AS MACHINED
2	30102-C	SWITCH BOARD ASSY
3	632-12-18-98	SCREW, #6-32 x 3/8 FLAT HD.
4	17543-A	CUP WASHER # 6
5	632-10-18-98	SCREW, #6-32 x 1/2 FLAT HD.
6	440-6-6-58	SCREW, #4-40 x 1/2 PAN HD.
7	3010-D	TUNER ASSY - TA3-1
8	30115-C	TUNER ASSY - TA3-1
9	30120-C	TUNER ASSY - TA3-3
10	5874-B	PLATE, GRAPHIC BAND SWITCH
11	30125-C	TUNER ASSY TA3-4
12	30130-C	TUNER ASSY TA3-5
13	30135-D	TUNER ASSY TA3-6
14	30140-D	TUNER ASSY TA3-7
15	30150-D	TUNER ASSY TA3-8
16	17542-A	WASHER, PANEL
17	440-12-6-58	SCREW #4-40 x 3/8 PAN HD.
18	24086-C	PLATE, BOTTOM, H.F.R.
19	8004-A	KNOB, CONTROL
20	8015-A	KNOB, SELECTOR
21	21011-A	BRACKET, SWITCH BOARD MTS.
22	18021-A	NUT, SPEED
23		
24	17542-A	WASHER, PANEL
25	632-10-18-98	SCREW #6-32 x 1/2 FLAT HD.
26	440-6-6-58	SCREW #4-40 x 1/2 PAN HD.

FIGURE 12.2

USED ON	17542-A	17543-A	17544-A	17545-A	17546-A	17547-A	17548-A	17549-A	17550-A
17542-A	17543-A	17544-A	17545-A	17546-A	17547-A	17548-A	17549-A	17550-A	
17542-A	17543-A	17544-A	17545-A	17546-A	17547-A	17548-A	17549-A	17550-A	
17542-A	17543-A	17544-A	17545-A	17546-A	17547-A	17548-A	17549-A	17550-A	
17542-A	17543-A	17544-A	17545-A	17546-A	17547-A	17548-A	17549-A	17550-A	
17542-A	17543-A	17544-A	17545-A	17546-A	17547-A	17548-A	17549-A	17550-A	
17542-A	17543-A	17544-A	17545-A	17546-A	17547-A	17548-A	17549-A	17550-A	
17542-A	17543-A	17544-A	17545-A	17546-A	17547-A	17548-A	17549-A	17550-A	
17542-A	17543-A	17544-A	17545-A	17546-A	17547-A	17548-A	17549-A	17550-A	
17542-A	17543-A	17544-A	17545-A	17546-A	17547-A	17548-A	17549-A	17550-A	

EP-100-U

ENLARGED VIEW SECTION A-A

SOLDER ONE END OF 3.3K RESISTOR TO PINS 1 & 2, THE OTHER END TO GROUNDING LUG.

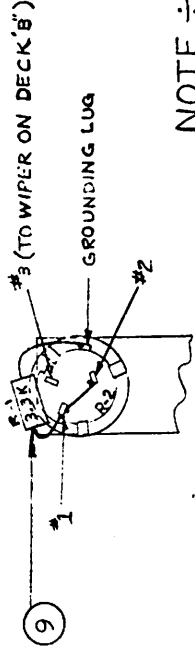

SECTION C C

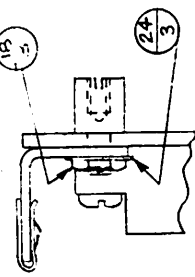

SECTION B B

CENTER CONDUCTOR OF COAX CONNECTS TO PIN 'F', SHIELD OF COAX CONNECTS TO PIN 'E' ON ALL CONNECTORS MOUNTED ON P.C. BOARD.

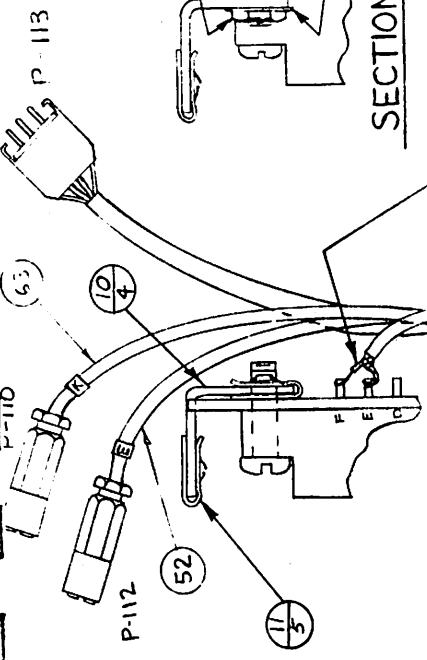

SECTION A A

TYP. INSTALLATION AT POINTS MARKED 'G'

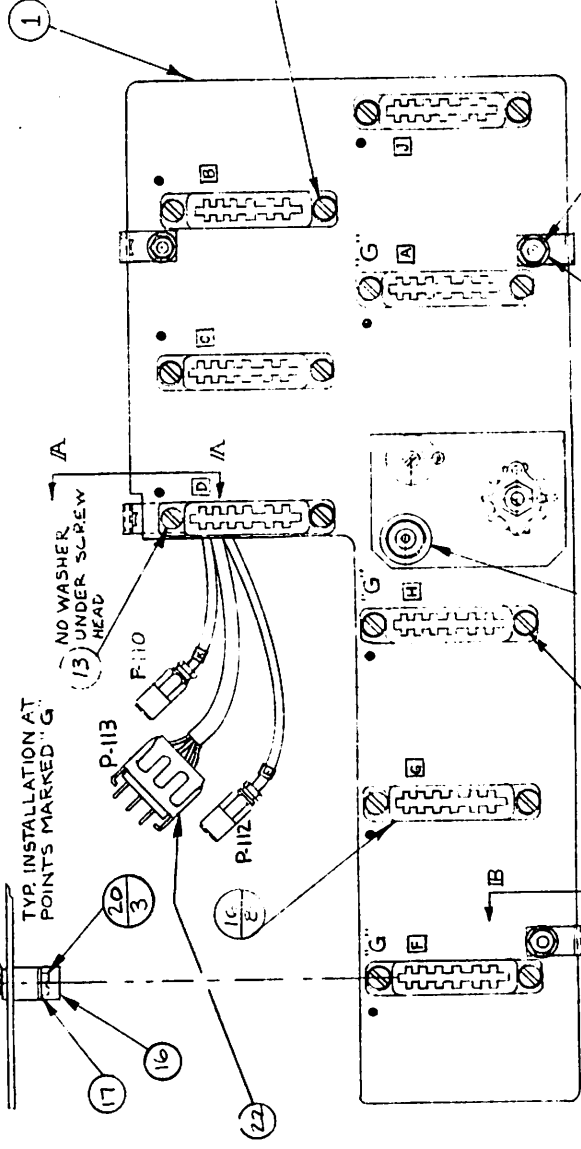

NOTE ÷

- 1) ALL MOUNTING HARDWARE FOR ITEMS 4 & 8 SUPPLIED WITH PURCHASED PARTS.
- 2) ② INDICATES MOUNTING HOLES FOR ROTARY SWITCH
- 3) □ INDICATES WIRE DESIGNATION COAX WIRES MUST HAVE WIRE MARKER'S ONE EACH FOR IDENTIFICATION.
- 4) ALL COAX SHIELDS TO BE GROUND TO BRACKET (ITEM 2) EXCEPT COAX LEAD ①
- 5) USE EXISTING NUT ON SWITCH FOR FASTENING
- 6) SEE SHEET 3 OF 3 FOR M.E.I. NUMBERS FOR WIRE MARKER'S.
- 7) LONG END OF BRACKET ITEM N° 10 MOUNTS ON BOARD.
- 8) USE LOCTITE ON ALL SCREWS. REFER TO M.E.I. LOCTITE STD - 5
- 9) FOR SCHEMATIC INFORMATION SEE SWD 4056-C

AFTER WIPING SWITCH ADJUSTMENT OF CABLE-TIE AS NEED

FIGURE 12.3A
GROUND SHIELD PORTION OF COAX TO PIN 9 & CENTER LEAD TO WIPER ON DECK "E"

USEL ON	TOLERANCES (UNLESS NOTED)	SCALE	DRAWN BY
1. 30100-D	DECIMAL	FULL	S.P.
	FRACTIONAL		APPROVED BY
	ANGULAR		
			TITLE
			SWITCHBOARD ASSY
			DATE
			6-11-65
			DRAWING NUMBER
			30102-C

REV.	DATE	BY	CHKD.	DESCRIPTION	REVISION RECORD	AUTH.	CHKD.
1	1/20	W.A.	W.A.	REVISED			
2	1/24	W.A.	W.A.	REVISED			
3	1/24	W.A.	W.A.	REVISED			
4	1/24	W.A.	W.A.	REVISED			
5	1/24	W.A.	W.A.	REVISED			
6	1/24	W.A.	W.A.	REVISED			
7	1/24	W.A.	W.A.	REVISED			
8	1/24	W.A.	W.A.	REVISED			
9	1/24	W.A.	W.A.	REVISED			
10	1/24	W.A.	W.A.	REVISED			

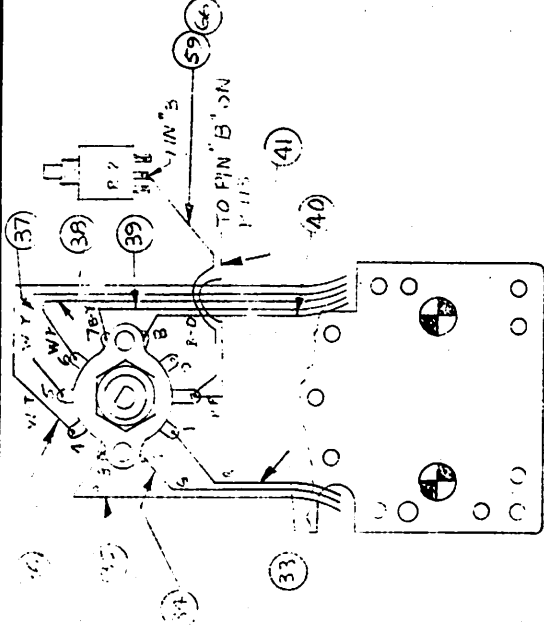

DECK "A"

DECK "B"

DECK "C"

DECK "E"

DECK "D"

DECK "F"

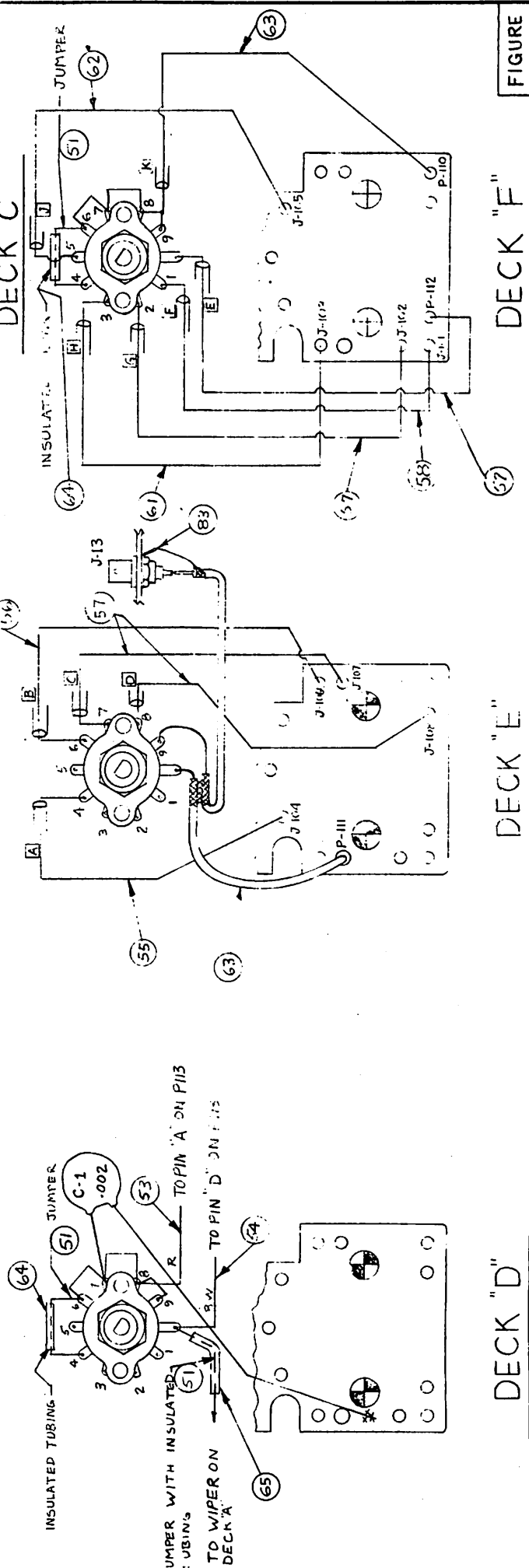
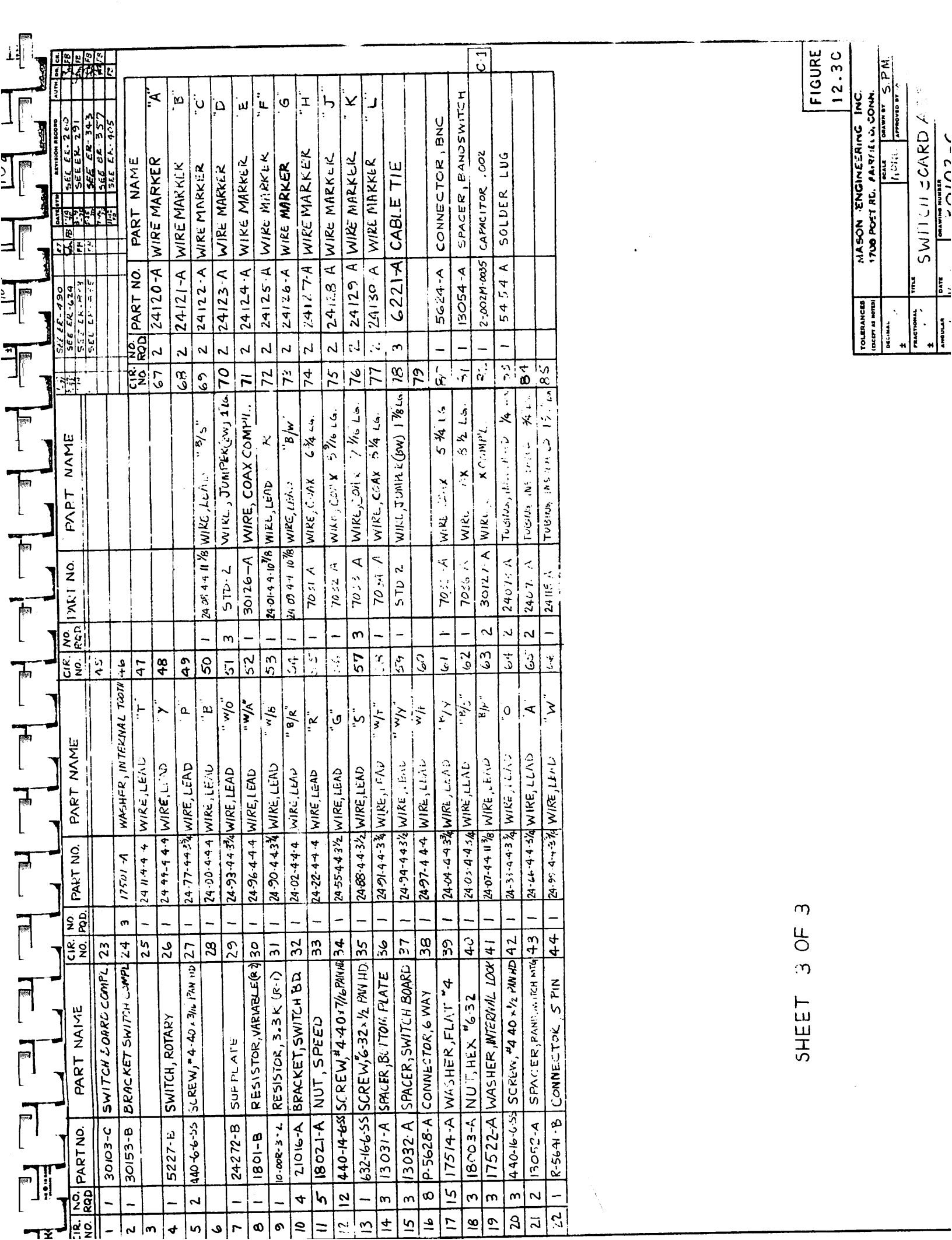

FIGURE 12.3 B

TOLERANCES (EXCEPT AS NOTED)	MASON ENGINEERING INC.
DIGITAL	1700 POST RD. FAIRFIELD, CONN.
FRACTIONAL	SCALE
ANGULAR	DRAWN BY
	NONET
	APPROVED BY
	DATE
	ISSUE NUMBER
	SWITCH BOARD AS'Y.
	ISSUE



CIR. NO.	PART NO.	PART NAME	CIR. NO. QTY.	PART NO.	PART NAME	CIR. NO. RSD	PART NO.	PART NAME	CIR. NO. RSD	PART NO.	PART NAME	CIR. NO. RSD	PART NO.	PART NAME	REV. RECORD	DATE
1	30103-C	SWITCH BOARD COMPL	23			45									SEE ER-490	12/18
2	30153-B	BRACKET SWITCH COMPL	24	17501-A	WASHER, INTERNAL TOOTH	46									SEE ER-629	12/18
3			25	24114-4-4	WIRE, LEAD "T"	47									SEE ER-291	12/18
4	5227-B	SWITCH, ROTARY	26	2444-4-4-4	WIRE, LEAD "Y"	48									SEE ER-343	12/18
5	440-6-6-55	SCREW, #4-40x3/16 PAN HD	27	2477-4-4-3/4	WIRE, LEAD "P"	49									SEE ER-343	12/18
6			28	2400-4-4-4	WIRE, LEAD "B"	50	2408-4-4-11/8	WIRE, LEAD "B/S"							SEE ER-357	12/18
7	24272-B	SUP PLATE	29	2493-4-4-3/4	WIRE, LEAD "W/O"	51	STD-2	WIRE, LEAD "B/S"							SEE ER-405	12/18
8	1801-B	RESISTOR, VARIABLE (R)	30	2496-4-4-4	WIRE, LEAD "W/A"	52	30126-A	WIRE, COAX COMPL.								
9	10-008-3-2	RESISTOR, 3.3K (R-D)	31	2490-4-4-3/4	WIRE, LEAD "W/B"	53	2409-4-4-10/16	WIRE, LEAD "K"								
10	21016-A	BRACKET, SWITCH BD	32	2402-4-4-4	WIRE, LEAD "B/R"	54	2409-4-4-10/16	WIRE, LEAD "B/W"								
11	18021-A	NUT, SPEED	33	2422-4-4-4	WIRE, LEAD "R"	55	7031 A	WIRE, COAX 5/16 LG.								
12	440-14-655	SCREW, #4-40x7/16 PAN HD	34	2455-4-4-3/2	WIRE, LEAD "G"	56	7032 A	WIRE, COAX 5/16 LG.								
13	632-16-6-55	SCREW, #6-32x1/2 PAN HD	35	2488-4-4-3/2	WIRE, LEAD "S"	57	7033 A	WIRE, COAX 7/16 LG.								
14	13031-A	SPACER, BOTTOM PLATE	36	2491-4-4-3/4	WIRE, LEAD "W/T"	58	7034 A	WIRE, COAX 5/4 LG.								
15	13032-A	SPACER, SWITCH BOARD	37	2494-4-4-3/4	WIRE, LEAD "W/Y"	59	STD 2	WIRE, JUMPER (P/W) 17/8 LG.								
16	P-5628-A	CONNECTOR, 6 WAY	38	2497-4-4-4	WIRE, LEAD "W/F"	60										
17	17514-A	WASHER, FLAT #4	39	2404-4-4-3/4	WIRE, LEAD "P/Y"	61	7035 A	WIRE, COAX 5 3/4 LG.								
18	18003-A	NUT, HEX #6-32	40	2405-4-4-3/4	WIRE, LEAD "B/S"	62	7036 A	WIRE, COAX 5 1/2 LG.								
19	17522-A	WASHER, INTERNAL LOCK	41	2407-4-4-11/8	WIRE, LEAD "B/H"	63	30127-A	WIRE, COAX COMPL.								
20	440-16-6-55	SCREW, #4-40x1/2 PAN HD	42	2433-4-4-3/4	WIRE, LEAD "O"	64	24075 A	TUBING, INTERNAL 1/4 LG.								
21	13052-A	SPACER, PANEL RICH MFG	43	2464-4-4-5/8	WIRE, LEAD "A"	65	24077 A	TUBING, INTERNAL 3/4 LG.								
22	R-5641-B	CONNECTOR, 5 PIN	44	2495-4-4-3/4	WIRE, LEAD "W"	66	24115 A	TUBING, INTERNAL 1 1/2 LG.								

TOLERANCES (EXCEPT AS NOTED)	MASON ENGINEERING INC. 1700 POST RD. FAIRFIELD, CONN.	
DECIMAL ±	SCALE 1:1000	DRAWN BY S.P.M.
FRACTIONAL ±	DATE	APPROVED BY
ANGULAR ±	TITLE SWITCH CARD A	FIGURE 12.3C

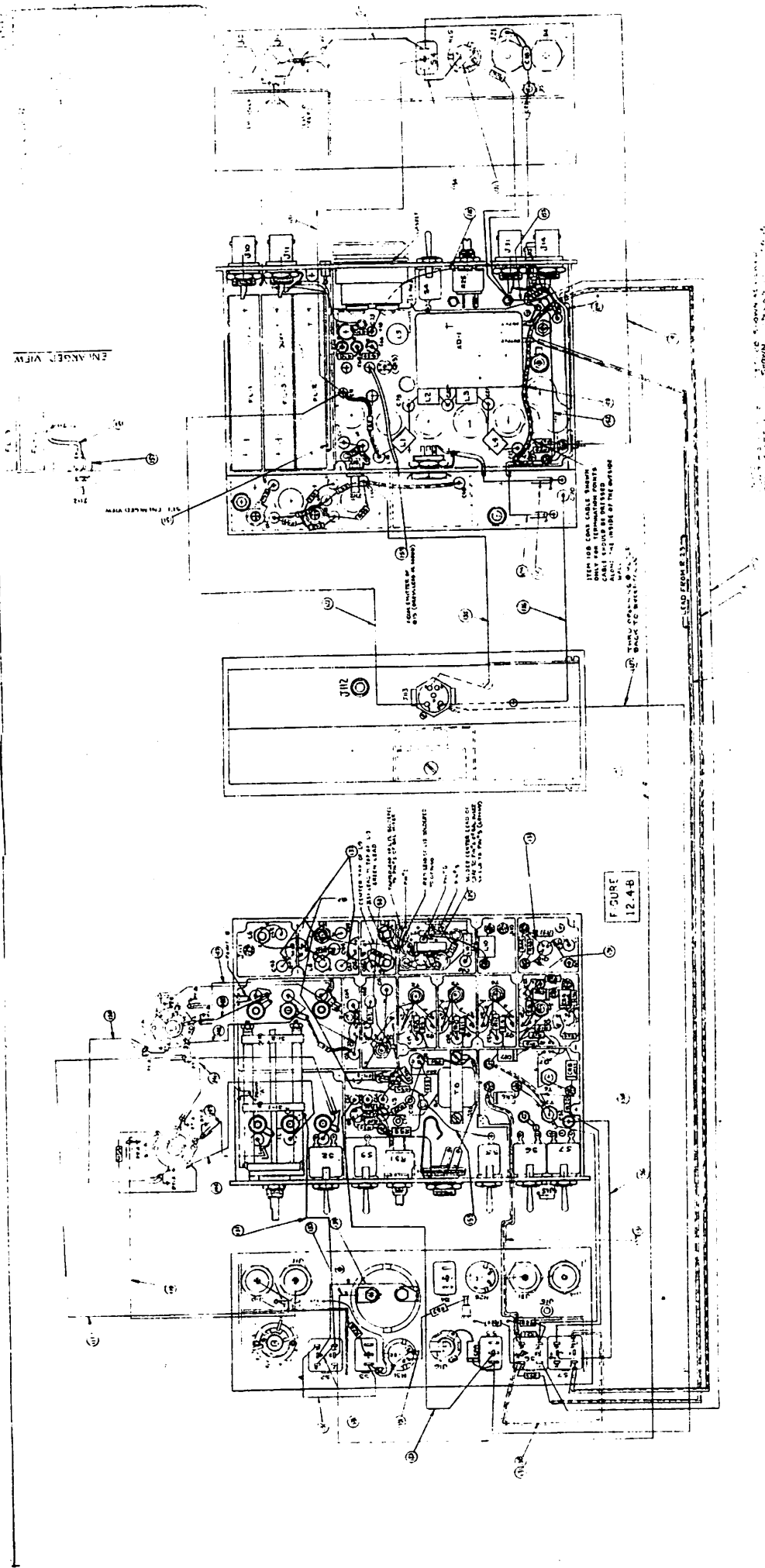

FIG. 12.

REV.	
NO.	DESCRIPTION
1	ISSUED FOR
2	REVISION
3	ISSUED FOR
4	REVISION
5	ISSUED FOR
6	REVISION
7	ISSUED FOR
8	REVISION
9	ISSUED FOR
10	REVISION

SCALE 1/2" = 1"

FIGURE 12.4B

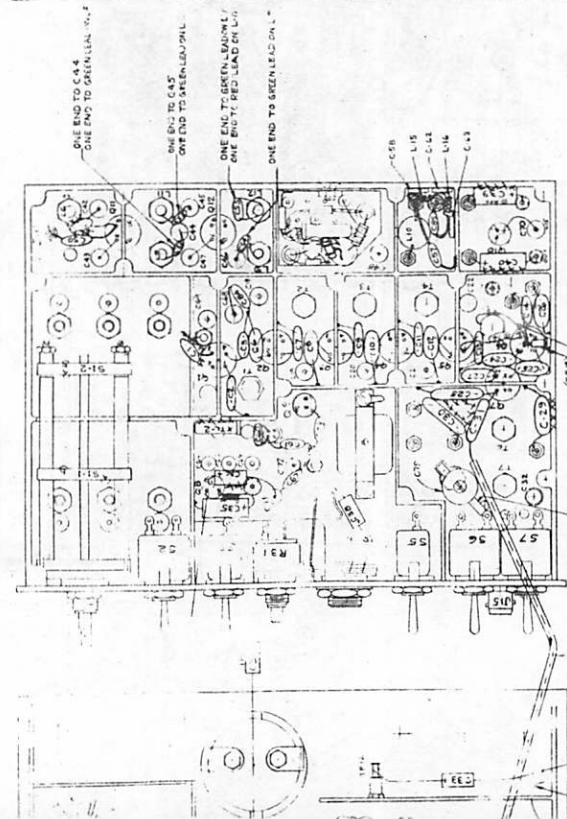
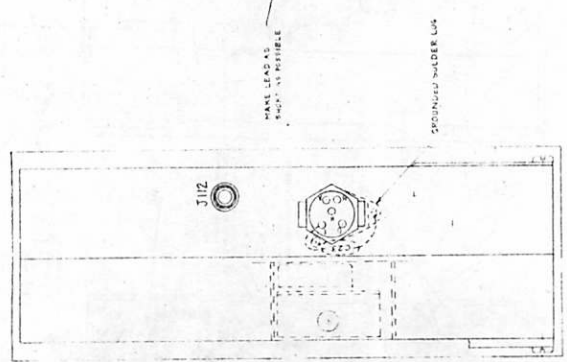
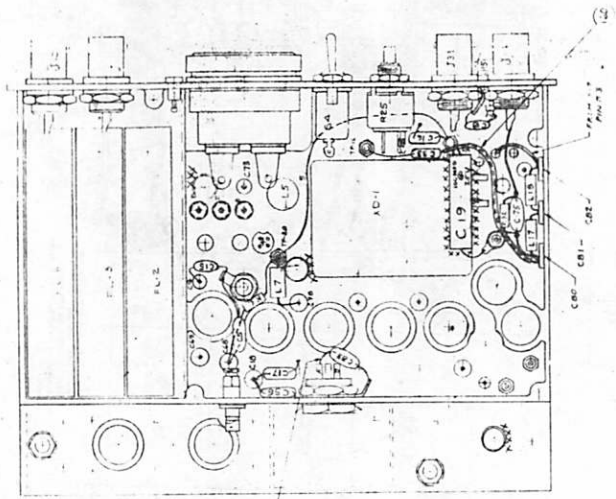

FIGURE 12.4C

NOTE ÷
 1. 'X' DENOTES APPLICATION OF RTV (ITEM #41) ON COMPONENTS FOR SHOCK ABSORPTION.

SHEET 3 OF 5

FIGURE 12.4A

DATE	12/15/50
BY	W. J. ...
CHECKED BY	...
APPROVED BY	...
DESIGNED BY	...
TESTED BY	...
REVISIONS	...

NOTE # 1
 GET TORQUES
 TO EXCEED
 INCH-OZ

1	SEE ER-216	RT
2	SEE ER-234	RT
3	SEE ER-254	RT
4	SEE ER-263	RT
5	SEE ER-271	RT
6	SEE ER-331	RT
7	SEE ER-288	RT
8	SEE ER-350	RT
9	SEE ER-352	RT
10	SEE ER-363	RT
11	SEE ER-374	RT
12	SEE ER-383	RT
13	SEE ER-421	RT
14	SEE ER-452	RT
15	SEE ER-459	RT
16	SEE ER-494	RT
17	SEE ER-549	RT
18	SEE ER-700	RT

COAX CABLE FROM
 P.C. BOARD ASSY. 4023
 SEE PWD-4023

NOTE #
 VIEW WITHOUT RF OSC CASES

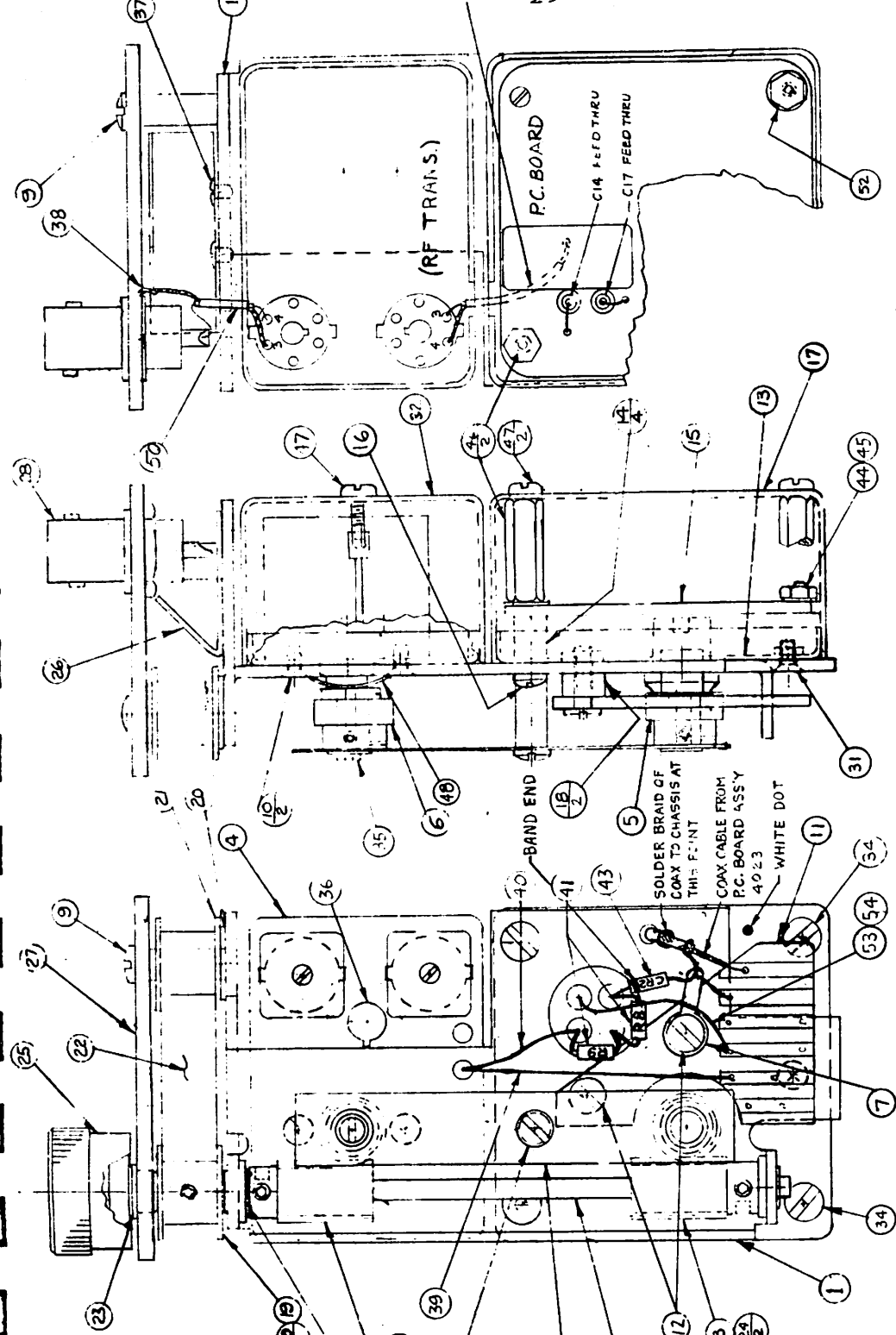

QTY	PART NO.	PART NAME	CIR NO.	NO. REQ.	PART NO.	PART NAME	CR NO.	NO. REQ.	PART NO.	PART NAME	CR NO.	NO. REQ.	PART NAME
1	3011-B	BRACKET COMPL. MFG	20	1	1764-A	WASHER, TEFLO	39	1	24-33-00	WIRE			
1	1500-A	SHAFT	21	1	1600-A	SPOOL, IDLER	40	1	24-33-00	WIRE			
2	902A	WORM	22	1	2300A	TAPE, DIAL	41	2	10-007-32	RESISTOR 330 Ω	R8	R9	
1	30116-B	COVER COMPL. R.F.	23	1	10000-A	BUZZING	42		4509-A	ZENER DIODE IN 1759A			
1	30191-A	DRIVE GEAR ASSY	24	4	256 3-358	2 7/32 SCREW	43		18001	NUT, HEX, 4-40			
1	30190A	DRIVE GEAR ASSY	25	1	8014-A	KNOB	44		17514	WASHER # 4 FLAT			
1	24007-A	SOLDER LUG #4	26	1	3013-A	PLATE WINDOW	46	2	13042-A	SPACER - ER			
1	44084-58	SCREW #4-40 x 1/4 BLACK	28	1	5663-A	CONNECTOR BNC	47	4	410-E-2-33	SCREW # 40-2 1/2 PAN HD			
2	3566-1A55	SCREW 3-56 x 1/4 FLT HD	29	1	17500-A	WASHER BOWED	48	1	24 257A	WIPER			
1	4022-A	BOARD CONNECTOR	30	2	440-4-555	SCREW SET	50	1	7001A	COAX 1/2 x 5/8			
1	44010-65	COVER #4 4016	31	1	256-4MSS	SCREW #2-56 FLAT HD	51		1722A	WASHER, SPACIAL LOCK			
1	30114A	COVER, OSC. COMPL	32	1	18004	CASE P.F.	52	1	STD. 2	WIRE JUMPER (BW)			
4	13-04-A	SPACER, P. V.F.	33	2	256-4MSS	SCREW #2-56 FLAT HD	53	1	34213A	INSULATING TUBING			
5	PWD4023D	P.C. BOARD ASSY	34	2	256-4MSS	SCREW #2-56 FLAT HD	54	1					
1	440-2MSS	SCREW #4-40 x 5/2 L3	35	1	354-164-3	SCREW #2-56 FLAT HD							
7	R-1206E8	CASE OSC	36	1	4749-A	TRANSISTOR 4C819							
6	13306A	SPACER, BOARD	37	2	256-4MSS	SCREW #2-56 FLAT HD							

FIGURE 12.5
 ER-100-P

MASON ENGINEERING INC.
 1700 POST RD. FAIRFIELD, CONN.

SCALE: 2:1
 DRAWN BY: A.L.S.
 APPROVED BY: J.P.B.

TOLERANCES (EXCEPT AS NOTED):
 DIMENSIONAL: ± .005
 ANGULAR: ± 1/4°
 SURFACE: ± 1°

USED ON: 1 30110C

DATE: 6-10-68
 DRAWING NUMBER: 30110-C

TUNER ASSY TA?

DATE	BY	REVISION RECORD	AUTH.	DR.	CK.
11/15		SEE ER-115			
5/72		SEE ER-350			FB
5/71		SEE ER-560			FR
5/71		SEE ER-640			FB

CIR. NO.	NO. REQ.	PART NO.	PART NAME
1	1	3012-B	COVER, COMPL. F.
2	5	STD	JUMPER WIRE
3	1	5432-A	SOCKET, TRANSFORMER
4	2	2011-A	TRANSFORMER R.F.
5	1	2514-B	VARIABLE CAPACITOR
6	5	24213A	INSULATING THERM
7	2	201M-0050	CAPACITOR .01
8	1	2-5001-01	CAPACITOR PEP DISC
9	1	10-5TB-2	RESISTOR 470K 1/4 W.
10	1	10-5TB-2	RESISTOR 1MEG 1/4 W.
11	1	10-5TB-2	RESISTOR 330K 1/4 W.
12	1	10-5TB-2	RESISTOR 33K 1/4 W.
13	1	7000-A	RG 186/COAX 2 1/8
14	1	2-68P-005B	CAPACITOR 68PF DISC.
15	2	10-5TB-3-2	RESISTOR 510 1/4 W.

TOP CENTER LUG SOLDERED TO CENTER SHIELD.
BOTTOM CENTER LUG SOLDERED TO COVER.

TOP & BOTTOM LUGS JOINED TOGETHER.

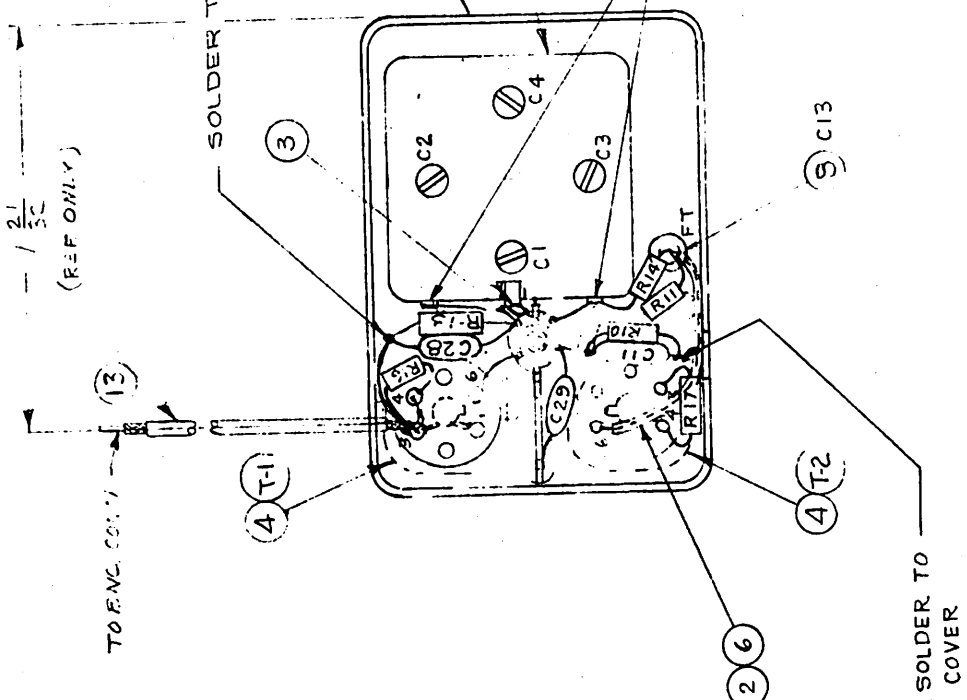

NOTES
FOR SCHEMATIC WIRING DIAGRAM SEE SWD 4023-B
FIGURE 12.6

TOLERANCES (EXCEPT AS NOTED)	SCALE	DRAWN BY	APPROVED BY
DECIMAL	2:1	ALS	KJ
FRACTIONAL			
ANGULAR			
TITLE	COVER ASSY R.F. TAB-1		
DATE	DRAWING NUMBER	ISSUE	
9-5-68	30116-B	5	

USED ON
1 30116-B

ER-100-D

REV	DATE	BY	CHK
1	10-1-54	W. J. B.	W. J. B.
2	10-1-54	W. J. B.	W. J. B.
3	10-1-54	W. J. B.	W. J. B.
4	10-1-54	W. J. B.	W. J. B.
5	10-1-54	W. J. B.	W. J. B.
6	10-1-54	W. J. B.	W. J. B.
7	10-1-54	W. J. B.	W. J. B.
8	10-1-54	W. J. B.	W. J. B.
9	10-1-54	W. J. B.	W. J. B.
10	10-1-54	W. J. B.	W. J. B.
11	10-1-54	W. J. B.	W. J. B.
12	10-1-54	W. J. B.	W. J. B.

QTY	PART NO	PART NAME
1	4026-C	PC BOARD AS MACHINED
2	5	WIRE JUMPER (8W)
3	1	5425-A SOCKET TRANSISTOR
4	1	474B-A TRANSISTOR 40894
5	5	2-215-A TUBING, INSULATED
6	1	19083-A COVER, COIL FORM
7		
8	1	10-40-32 RESISTOR 2.4K 1/4W 5%
9	2	10-76R-32 RESISTOR 1.5K 1/4W 5%
10	1	10-00T-32 RESISTOR 550Ω 1/4W 5%
11	1	10-1P4-32 RESISTOR 4.7K 1/4W 5%
12		
13		
14	2	100K-400 CAPACITOR .001MED OUTP
15	2	15P-500 CAPACITOR .015P
16	1	2-215-M35 TUBING
17	1	2-215-M35 TUBING
18	1	2-215-M35 TUBING
19	1	2-215-M35 TUBING
20	1	2507-A CAPACITOR POLY VARIAB
21	1	2-215-M35 TUBING
22	1	30L-9-A COL. OSC TABS
23	1	5034-B MIXER, DUBLY BALANCE
24	1	4508-A DIODE, FD-717
25		
26	1	100L-A WIRE, COAX 2.75
27	1	100L-A WIRE, COAX 2.75
28	1	5042-A SOLDER LUG
29	1	5042-A SOLDER LUG
30	1	5042-A SOLDER LUG

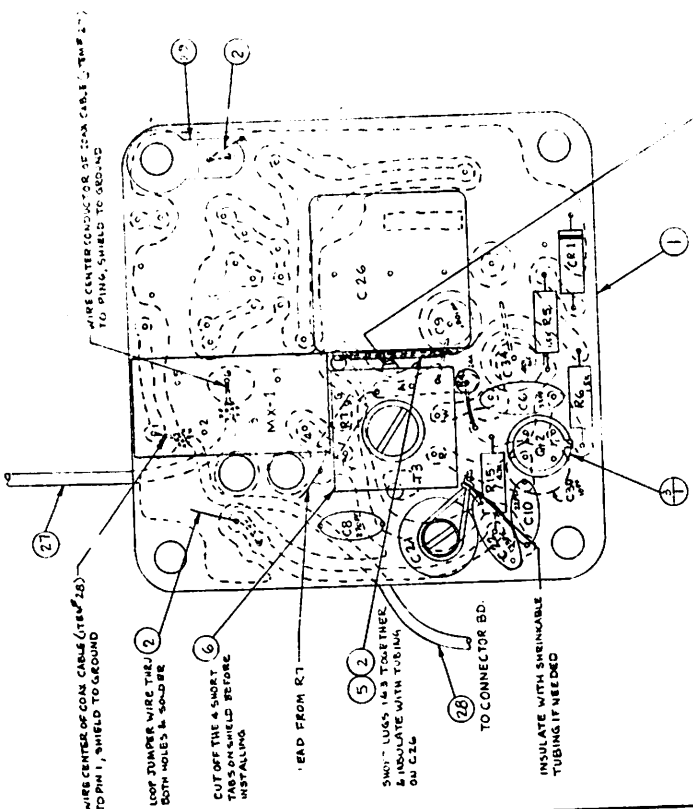
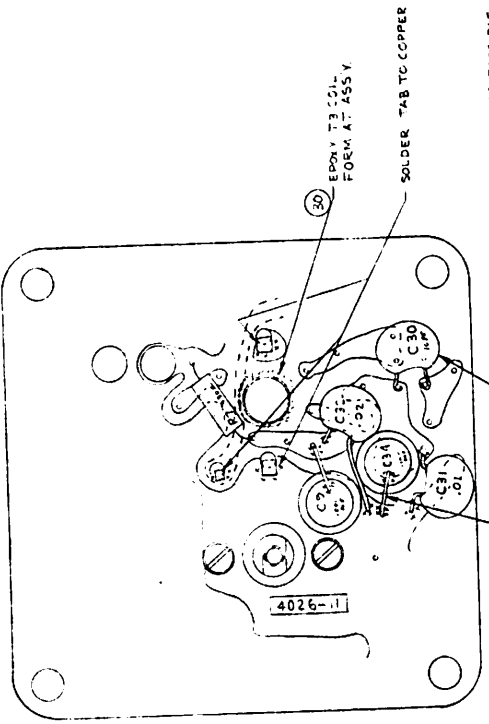

FIG: 12

USED ON	QUANTITY	REVISION
1 3010-C	1	1

MAGSON ENGINEERING INC
1000 POST RD. FAIRFIELD, CONN.

DATE: 10-1-54
BY: W. J. B.
CHK: W. J. B.

2-16-71 PWD-4023-D

REV	DESCRIPTION	DATE	BY
1	SEE ER-216		
2	SEE ER-216		
3	SEE ER-216		
4	SEE ER-216		
5	SEE ER-216		
6	SEE ER-216		
7	SEE ER-216		
8	SEE ER-216		
9	SEE ER-216		
10	SEE ER-216		
11	SEE ER-216		
12	SEE ER-216		
13	SEE ER-216		
14	SEE ER-216		
15	SEE ER-216		
16	SEE ER-216		
17	SEE ER-216		
18	SEE ER-216		
19	SEE ER-216		
20	SEE ER-216		
21	SEE ER-216		
22	SEE ER-216		
23	SEE ER-216		
24	SEE ER-216		
25	SEE ER-216		
26	SEE ER-216		
27	SEE ER-216		
28	SEE ER-216		
29	SEE ER-216		
30	SEE ER-216		
31	SEE ER-216		
32	SEE ER-216		
33	SEE ER-216		
34	SEE ER-216		
35	SEE ER-216		
36	SEE ER-216		
37	SEE ER-216		
38	SEE ER-216		
39	SEE ER-216		
40	SEE ER-216		
41	SEE ER-216		
42	SEE ER-216		
43	SEE ER-216		
44	SEE ER-216		
45	SEE ER-216		
46	SEE ER-216		
47	SEE ER-216		
48	SEE ER-216		
49	SEE ER-216		
50	SEE ER-216		
51	SEE ER-216		
52	SEE ER-216		
53	SEE ER-216		
54	SEE ER-216		
55	SEE ER-216		
56	SEE ER-216		
57	SEE ER-216		
58	SEE ER-216		
59	SEE ER-216		
60	SEE ER-216		
61	SEE ER-216		

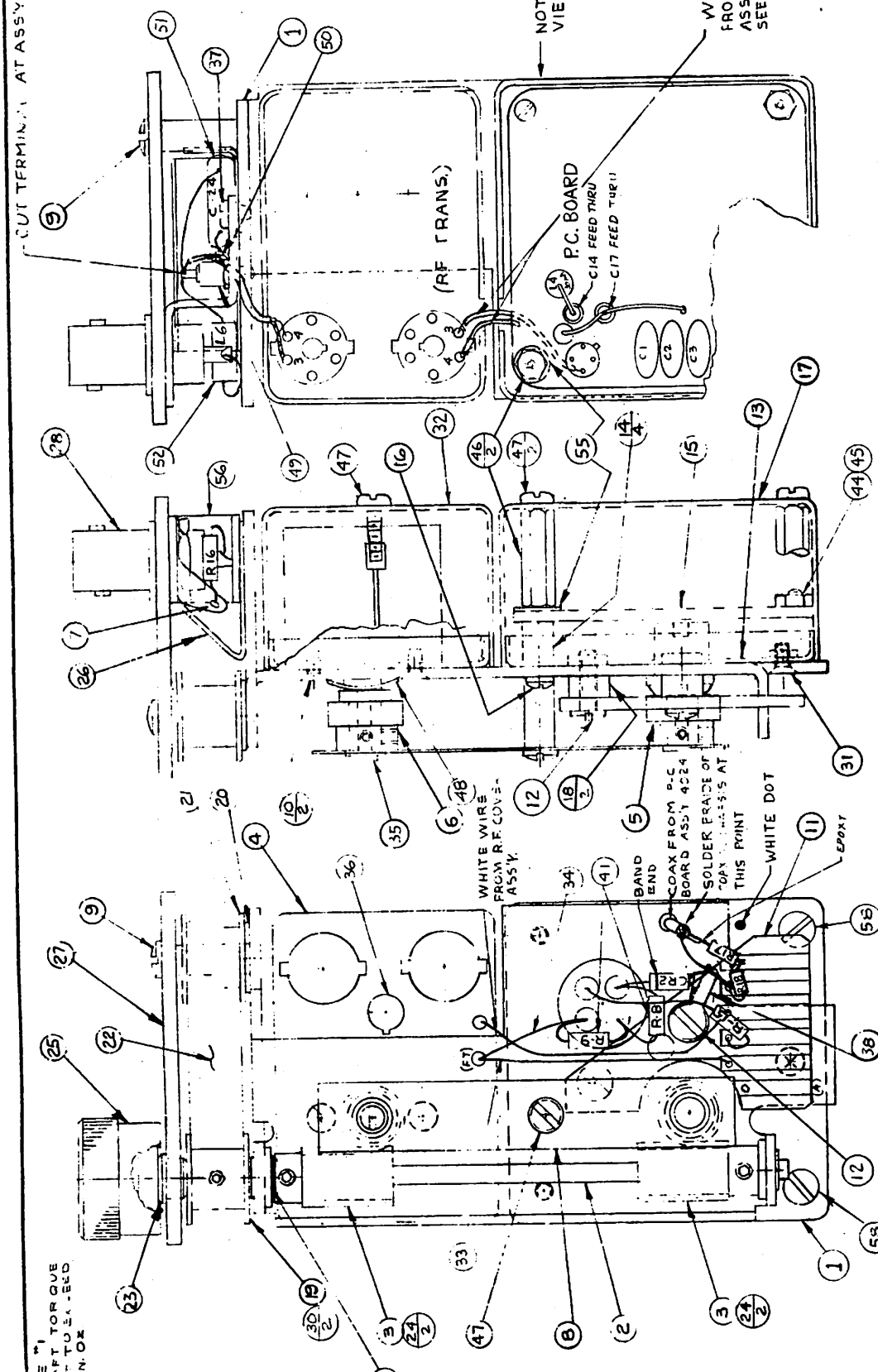

NO. REQ.	PART NO.	PART NAME	CIR. NO. REQ.	PART NO.	PART NAME	QTY. REQ.	PART NO.	PART NAME	R17
1	30111-B	BRACKET COMPL. KIT	20	1754-A	WASHER, TYPICAL	39	10-TB-2	RESISTOR 100Ω	R17
1	15001-A	SHAFT	21	16000-A	SPOOL IDLER	40	10-KRB-2	RESISTOR 22 Ω	R18
2	9002-A	WORM	22	23008-A	TAPE DIAL	41	10-DOT-3-2	RESISTOR 330Ω	R19
1	30117-B	COVER COMPL. R.F.	23	10000-A	BUSHING	42	10-YPK-3-2	RESISTOR 1.7 Ω	R15
1	30191-A	DRIVE GEAR ASSY	24	256-3-528	BUSHING 2.56 X 3.5	43	45-3-A	ZENER DIODE 1N 3.9A	CR4
1	30190-A	DRIVE GEAR ASSY	25	3014-A	KNOB	44	18001	NUT, HEX, 4-40	CIR. NO. 200
1	5454-A	SOLDER LUG	26	24052-B	M.I.	45	17514	WASHER 4-40 FLAT	58
1	24007-A	PLATE 2, BEAR	27	30123-B	PLATE WINDOW COMPL.	46	13042-A	SPACER, HEX	55
2	4086-55	SCREW 3-56 X 1/4 FLT HD (BLACK)	28	17500-A	CONNECTOR BNC.	47	440-B-6-55	SCREW, 4-40 X 1/4 PHD.	60
2	3616-1A55	SCREW 3-56 X 1/4 FLT HD	29	17500-A	WASHER BOWED	48	24257-A	WIPER	61
2	4022-A	BOARD CONNECTOR	30	440-4-5-55	SCREW SET	49	5440-A	TERMINAL INSULATED	
2	44016-55	SCREW 4-40 X 1/4	31	256-4-1A55	SCREW 2-56 FLAT HD	50	5455-A	SOLDER LUG	
4	30114	COVER 0.5\"/>							

FIGURE 12.8

ER-100-P

MASON ENGINEERING INC.
1700 POST RD. FAIRFIELD, CONN.

SCALE: 2:1
DRAWN BY: A.L.S.
CHECKED BY: J.C.B.

TOLERANCES (UNLESS OTHERWISE SPECIFIED):
ORIGINAL ± .005
REPRODUCTION ± .010

TUNER ASSY TA3-2
G-10-68 30115-C

2 13006-A SPACE L...
 54 SOL...
 57

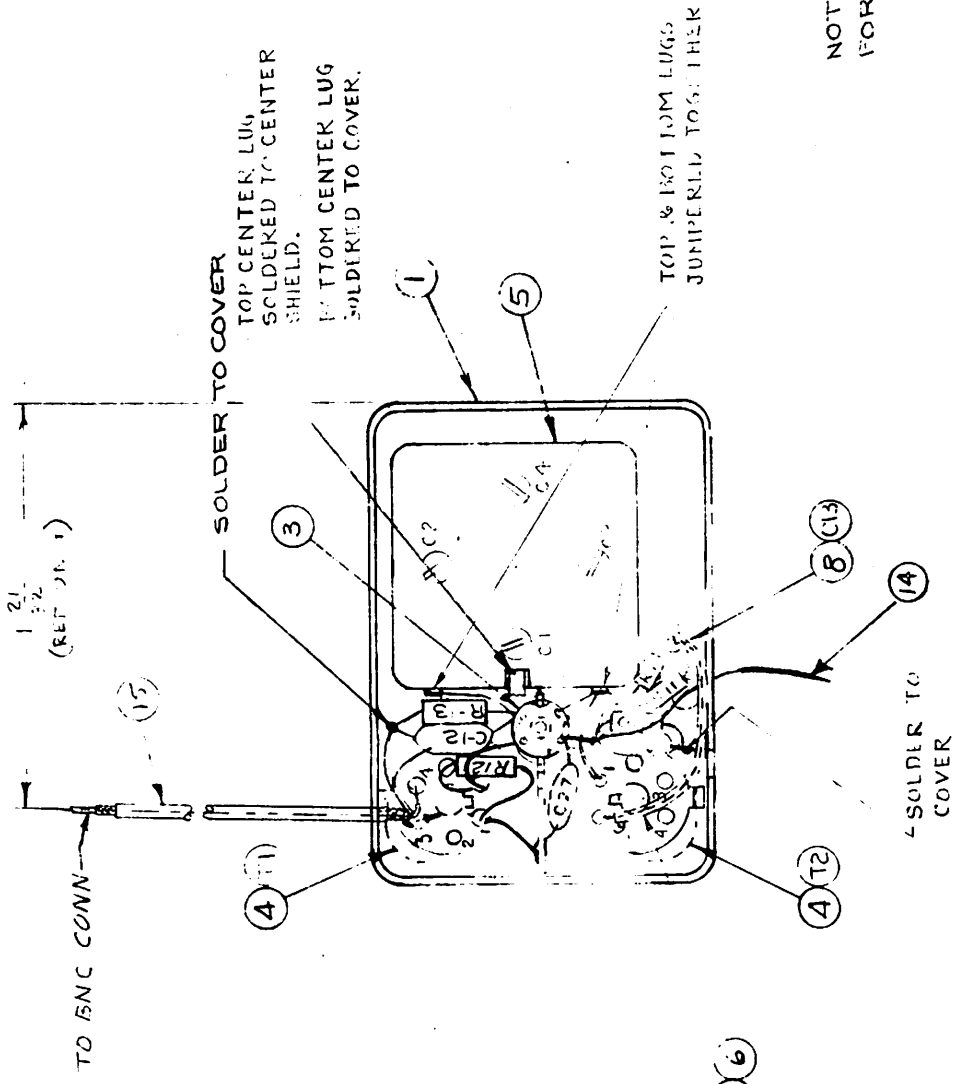

DATE	BY	REVISION RECORD	AUTH.	DR.	CR.
7-1-68	SEE ER-172				7/2
6-22-68	SEE ER-354				FB
7-6-68	SEE ER-842				FB

CR. NO.	QTY.	PART NO.	PART NAME
1	1	30121-B	COVER ASS'Y R.F.
2	5	STD.	JUMPER WIRE
3	1	5422-A	SOCKET, TRANSISTOR
4	2	3012-A	TRANSFORMER R.F.
5	1	2516-B	VARIABLE CAPACITOR
6	1	24213A	INSULATING WIRE
7	2	201M-0090	CAPACITOR .01
8	1	2-1500P-0032	CAPACITOR FEED THRU 1500PF
9	1	10-YPY-3-2	RESISTOR 470K 1/4W
10	1	10-TB6-3-2	RESISTOR 1MEG. 1/4W
11	1	10-YPO-3-2	RESISTOR 47K 1/4W
12	1	10-00T-3-2	RESISTOR 330Ω 1/4W
13	1	10-TB0-3-2	RESISTOR 10K 1/4W
14	1	24-9-6-6-22	WIRE
15	1	7000-A	RG 196/L COAX
16	1	2-68P-0058	CAPACITOR 68PF

NOTE 4
 FOR SCHEMATIC WIRING DIAGRAM SEE SWD 4024-B

FIGURE 12.9

TOLERANCES (EXCEPT AS NOTED)	DECIMAL	FRACTIONAL	ANGULAR
	± .005	± .005	± .005

USED ON	1	30115-C

MASON ENGINEERING INC. 1700 POST RD. FAIRFIELD, CONN.		SCALE	2:1	DRAWN BY	ALS
		APPROVED BY			
TITLE		COVER ASS'Y R.F.			
		TAG-2			
DATE	9-5-68	DRAWING NUMBER	30117-B		
ISSUE	4				

ER-100-D

REV	DATE	BY	REVISION RECORD	AUTH	DR	LA
1	12-12-57	W	INITIAL DESIGN			
2	1-15-58	W	REVISED TO 15P-150			
3	2-11-58	W	REVISED TO DIM-150			
4	3-11-58	W	REVISED TO CAP-150			
5	4-11-58	W	REVISED TO TRANSFORMER			
6	5-11-58	W	REVISED TO WIRE			
7	6-11-58	W	REVISED TO WIRE			
8	7-11-58	W	REVISED TO WIRE			
9	8-11-58	W	REVISED TO WIRE			
10	9-11-58	W	REVISED TO WIRE			
11	10-11-58	W	REVISED TO WIRE			
12	11-11-58	W	REVISED TO WIRE			
13	12-11-58	W	REVISED TO WIRE			
14	1-11-59	W	REVISED TO WIRE			
15	2-11-59	W	REVISED TO WIRE			
16	3-11-59	W	REVISED TO WIRE			
17	4-11-59	W	REVISED TO WIRE			
18	5-11-59	W	REVISED TO WIRE			
19	6-11-59	W	REVISED TO WIRE			
20	7-11-59	W	REVISED TO WIRE			
21	8-11-59	W	REVISED TO WIRE			
22	9-11-59	W	REVISED TO WIRE			
23	10-11-59	W	REVISED TO WIRE			
24	11-11-59	W	REVISED TO WIRE			
25	12-11-59	W	REVISED TO WIRE			
26	1-11-60	W	REVISED TO WIRE			
27	2-11-60	W	REVISED TO WIRE			
28	3-11-60	W	REVISED TO WIRE			
29	4-11-60	W	REVISED TO WIRE			
30	5-11-60	W	REVISED TO WIRE			

QIP NO. PART NO. (REV.)	PART NAME
1-3	2-0003 CAP 100 0.02-150
1-2	15P-0062 CAP 150 15P-150
1-2	01M-150 DIM-150
1-2	2-35P-0714 CAPACITOR 33P-150
1-2	2-507-A CAPACITOR
1-2	2-517-A CAPACITOR B-55PF
1-2	1-10TGP 3 RESISTOR 15K 1/4W 5%
1-2	1-10TGP 3 RESISTOR 15K 1/4W 5%
1-2	1-10TGP 3 RESISTOR 1900 1/4W 5%
1-2	1-10TGP 3 RESISTOR 330 1/4W 5%
1-2	1-10TGP 3 RESISTOR 33K 1/4W 5%
1-2	3-016-A TRANSFORMER
1-2	3-611-A OSC COIL
1-2	4-508 DIODE FU 777
1-2	4-749-A XISTOR 40B19
1-2	4-748-A XISTOR 40B94
1-2	5-425-A XISTOR SOCKET
1-2	5-483-A SOLDER LUG
1-2	2-10P-0011 CAPACITOR 10P -150
1-2	4-024-C P.C. BOARD
1-2	7-001 RG 146/U COAX 2'
1-2	8-1 STR-2 WIRE, JUMPER (BW)
1-2	9-1 WIRE
1-2	10-1 WIRE
1-2	11-1 WIRE
1-2	12-1 WIRE
1-2	13-1 WIRE
1-2	14-1 WIRE
1-2	15-1 WIRE
1-2	16-1 WIRE
1-2	17-1 WIRE
1-2	18-1 WIRE
1-2	19-1 WIRE
1-2	20-1 WIRE
1-2	21-1 WIRE
1-2	22-1 WIRE
1-2	23-1 WIRE
1-2	24-1 WIRE
1-2	25-1 WIRE
1-2	26-1 WIRE
1-2	27-1 WIRE
1-2	28-1 WIRE
1-2	29-1 WIRE
1-2	30-1 WIRE

-MOUNTING SCREWS SUPPLIED WITH CAP.

PISTON TRIMMER SCREWDRIVER SLOT ON TOP

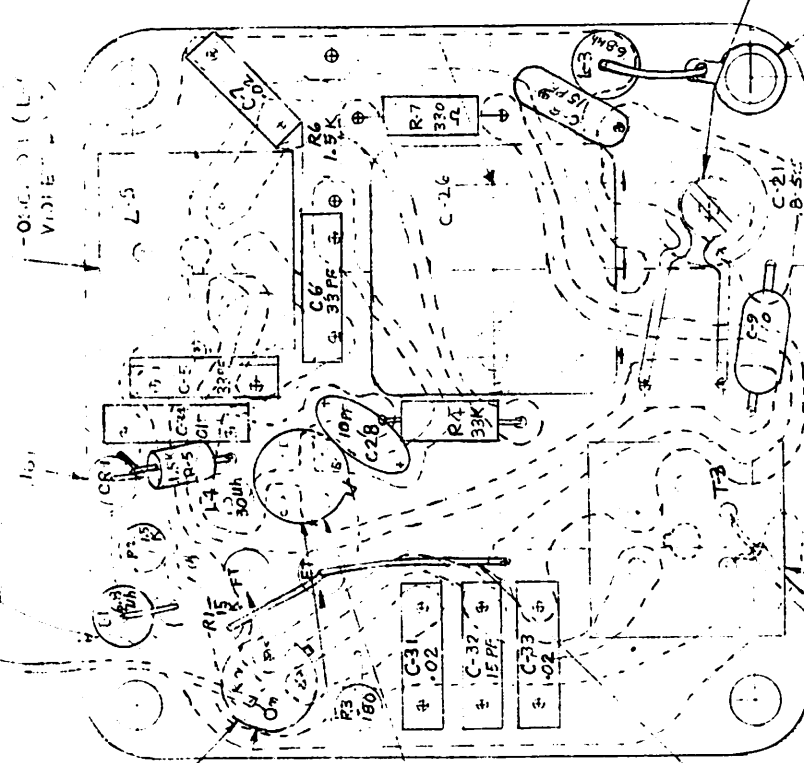

TR-1 40894 (Q-3)

19 -> TRANSISTOR SOCKET

C-14 (RE ONLY)

C-17 (RE ONLY)

TRANSISTOR 40B19 (Q-2)

I.F. COIL (GREEN DOT) T-3

TO I.F. COIL (GREEN DOT) T-3

FIGURE 12.10

TOLERANCES (UNLESS AS NOTED)	RESISTORS	1% 5% 10% 20%
DECIMAL	4.1	2.2
FRACTIONAL	1/2	1/4
ANGULAR		
USED ON	1 30115	
DATE	12-11-59	
TITLE	PICTORIAL WIRING DIAGRAM	
TAB	TA3-2	
DESIGNED BY	WJ	
APPROVED BY	WJ	
DATE	12-11-59	
SCALE	4:1	
DRAWN BY	WJ	
CHECKED BY	WJ	
DATE	12-11-59	

REV	DATE	BY	DESCRIPTION
1			ASSEMBLY
2			ASSEMBLY
3			ASSEMBLY
4			ASSEMBLY
5			ASSEMBLY
6			ASSEMBLY
7			ASSEMBLY
8			ASSEMBLY
9			ASSEMBLY
10			ASSEMBLY
11			ASSEMBLY
12			ASSEMBLY
13			ASSEMBLY
14			ASSEMBLY
15			ASSEMBLY
16			ASSEMBLY
17			ASSEMBLY
18			ASSEMBLY
19			ASSEMBLY
20			ASSEMBLY
21			ASSEMBLY
22			ASSEMBLY
23			ASSEMBLY
24			ASSEMBLY
25			ASSEMBLY
26			ASSEMBLY
27			ASSEMBLY
28			ASSEMBLY
29			ASSEMBLY
30			ASSEMBLY
31			ASSEMBLY
32			ASSEMBLY
33			ASSEMBLY
34			ASSEMBLY
35			ASSEMBLY
36			ASSEMBLY
37			ASSEMBLY
38			ASSEMBLY
39			ASSEMBLY
40			ASSEMBLY
41			ASSEMBLY
42			ASSEMBLY
43			ASSEMBLY
44			ASSEMBLY
45			ASSEMBLY
46			ASSEMBLY
47			ASSEMBLY
48			ASSEMBLY
49			ASSEMBLY
50			ASSEMBLY
51			ASSEMBLY
52			ASSEMBLY
53			ASSEMBLY
54			ASSEMBLY
55			ASSEMBLY
56			ASSEMBLY
57			ASSEMBLY
58			ASSEMBLY
59			ASSEMBLY
60			ASSEMBLY
61			ASSEMBLY
62			ASSEMBLY
63			ASSEMBLY
64			ASSEMBLY
65			ASSEMBLY
66			ASSEMBLY
67			ASSEMBLY
68			ASSEMBLY
69			ASSEMBLY
70			ASSEMBLY
71			ASSEMBLY
72			ASSEMBLY
73			ASSEMBLY
74			ASSEMBLY
75			ASSEMBLY
76			ASSEMBLY
77			ASSEMBLY
78			ASSEMBLY
79			ASSEMBLY
80			ASSEMBLY
81			ASSEMBLY
82			ASSEMBLY
83			ASSEMBLY
84			ASSEMBLY
85			ASSEMBLY
86			ASSEMBLY
87			ASSEMBLY
88			ASSEMBLY
89			ASSEMBLY
90			ASSEMBLY
91			ASSEMBLY
92			ASSEMBLY
93			ASSEMBLY
94			ASSEMBLY
95			ASSEMBLY
96			ASSEMBLY
97			ASSEMBLY
98			ASSEMBLY
99			ASSEMBLY
100			ASSEMBLY

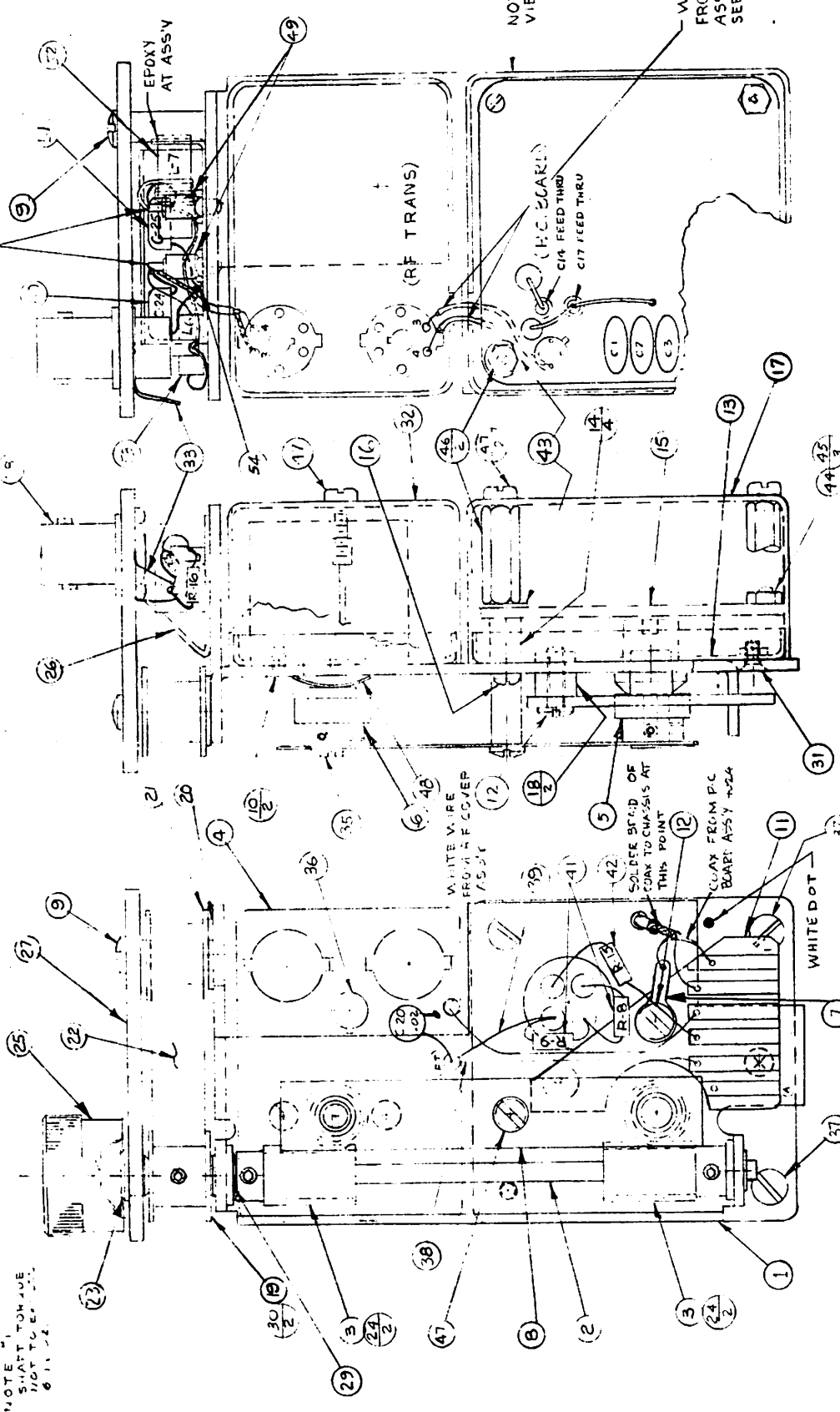

NOTE 7
VIEW WITHOUT RF OSC CASES

Wires
FROM PC BOARD
ASSY 4025
SEE PWD 4025

FIGURE
12.11

TOLERANCES (EXCEPT AS NOTED)	ASSEMBLY
ORIGINAL	SCALE 2:1
FUNCTIONAL	APPROVED BY ALS
MASON ENGINEERING INC. 1700 POST RD. FAIRFIELD, CONN.	
ER-100-P	
TUNER ASSY TA3-3	

CR NO.	REC NO.	PART NAME	CR NO.	REC NO.	PART NAME	CR NO.	REC NO.	PART NAME	CR NO.	REC NO.	PART NAME
1	1	5011-B BRACKET COMP. M16	20	1	1754-A WASHER, TEF-ON	39	1	2433-641 WIRE			
2	1	5001-A SHAFT	21	1	1600-A SPOOL, IDLER	40	1	IF GT 32 RESISTOR 570Ω	R16		
3	2	5002-A WORM	22	1	23008-A TAPE, DIAL	41	2	4007-2 RES. 330Ω	R149		
4	1	30118-B COVER, CRIP. S.F.	23	1	10000-A BUSHING	42	1	1000-2 RES. 33K	R15		
5	1	30191-A DRIVE GEAR, ASSY	24	4	625-2 2.5X 1/4 SET SCREW	43	1	1752-2-A WASHER, INTERNAL LOCK			
6	1	30190-A DRIVE GEAR, ASSY	25	1	8014-7 KNOB	44	1	18001 NUTS, HEX. 4-40			
7	1	5449-A SOLDER BRIDGE	26	1	240538-PIRZ	45	2	17514 WASHER, 4-FLAT			
8	1	24007-A PLATE, GEAR	27	1	17514 WASHER, 4-FLAT	46	1	17514 WASHER, 4-FLAT			
9	2	44084-388 SCREW #4-40 x 1/8	28	1	5663-A CONNECTOR, BNC.	47	1	2545-3-40 1/4 PAN HD. WIRE			
10	2	356-14-55 SCREW 3-56 x 1/4 x 1/8	29	1	17500-A WASHER BOWED	48	1	2545-3-40 1/4 PAN HD. WIRE			
11	2	4022-A BOARD, CONNECTOR	30	1	440-4-35 SCREW SET	49	2	5-4-A TERMINAL INSULATED			
12	2	440-4-35 SCREW #4-40 x 1/8	31	1	266-41851 SCREW #2-56 FLAT HD	50	1	17500-A WASHER BOWED			
13	1	30114-A COVER, 250	32	1	1835-4-A CASE P.F.	51	1	266-41851 SCREW #2-56 FLAT HD			
14	4	13004-A SPACER, BOARD	33	1	545-4-A S	52	1	3872-A COIL, 50-4H			
15	1	440-261 SCREW #4-40 x 1/8	34	1	36114-3 SCREW 3-56, FLAT HD, 1/2 L.	53	1	3619-A COIL, 50-4H			
16	1	440-261 SCREW #4-40 x 1/8	35	1	36114-3 SCREW 3-56, FLAT HD, 1/2 L.	54	1	3619-A COIL, 50-4H			

DATE	BY	REVISION RECORD	AUTH.	DR.	CL.
12/24/58	AL				
1/15/59	AL	SEE ER-353			
2/10/59	AL	SEE ER-312			

CR. NO.	QTY.	PART NO.	PART NAME
1	1		COVER, COMPL R.F.
2	1		WIRE
3	1	5422-A	SOCKET, TRANSISTOR
4	2	5015-A	TRANSFORMER R.F.
5	1	2516-R	VARIABLE CAPACITOR
6	1		INSULATING TUBING
7	1		CONDUCTIVE TAPE
8	1	202M-0313	CAPACITOR .02
9	1	2-500-0032	CAPACITOR 500PF
10	1	10YP-3-2	RESISTOR 470K 1/4W
11	1	10-186-3-2	RESISTOR 1MEG 1/4W
12	1	10-00T-3-2	RESISTOR 330Ω 1/4W
13	1	10-180-3-2	RESISTOR 10K 1/4W
14	1	24-9-66-2 1/2	WIRE
15	1	7000A	RG 196/U COAX .2"
16	1	2-68P-0058	CAPACITOR, DISC 68PF

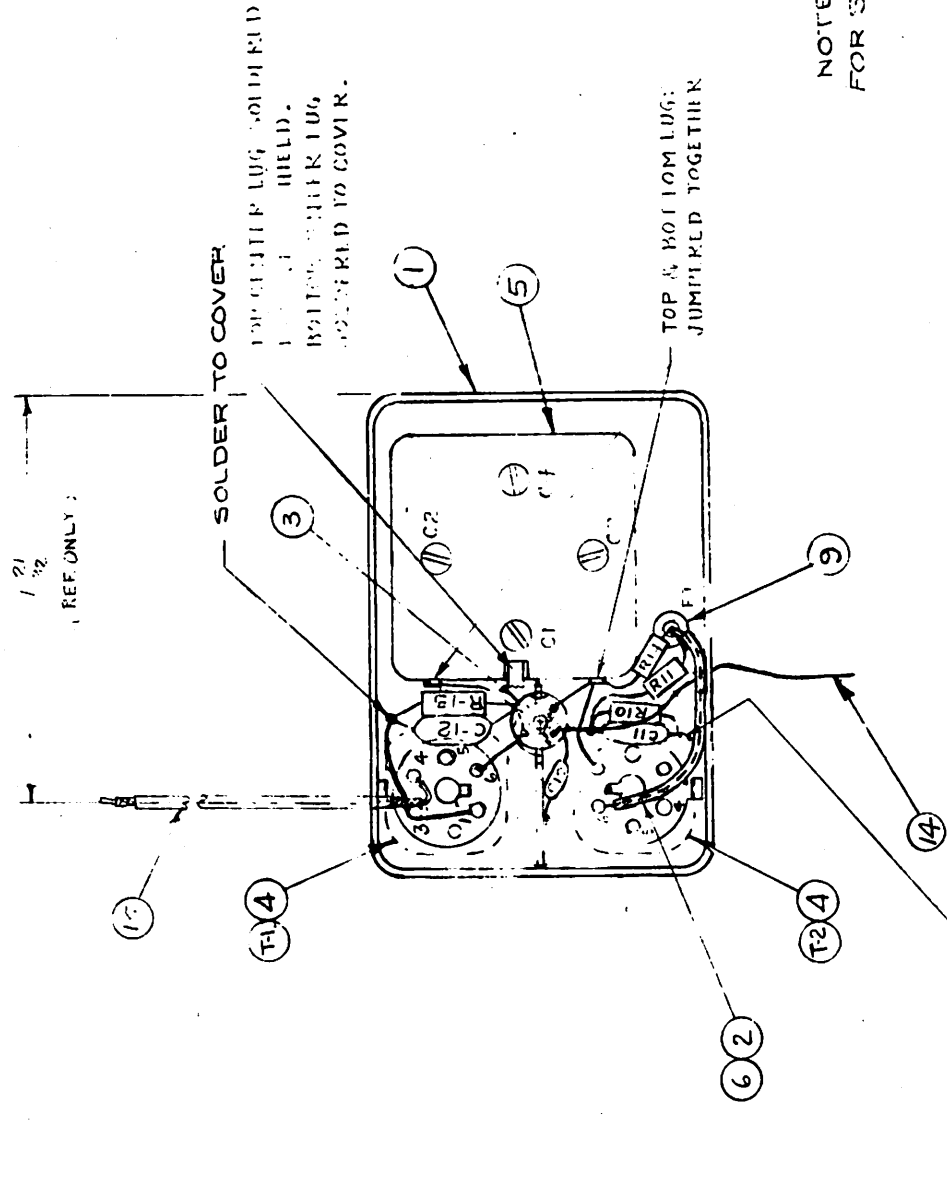

NOTE:
FOR SCHEMATIC WIRING DIAGRAM SEE SWD 4025-B

FIGURE
12.12

TOLERANCES (EXCEPT AS NOTED)		MASON ENGINEERING INC. 1700 POST RD. FAIRFIELD, CONN.	
DECIMAL	±	SCALE	2:1
FRACTIONAL	±	DRAWN BY	ALS
ANGULAR	±	APPROVED BY	KJ
USED ON	1 30120-C	TITLE	COVER ASSY R.F. TA3-3
DATE	9-5-68	DRAWING NUMBER	30118-B
ISSUE	4		

ER-100-D

1	SEE ER-353
2	SEE ER-422
3	SEE ER-500
4	SEE ER-700
5	SEE ER-823
6	SEE ER-842
7	SEE ER-842
8	SEE ER-842
9	SEE ER-842
10	SEE ER-842
11	SEE ER-842
12	SEE ER-842
13	SEE ER-842
14	SEE ER-842
15	SEE ER-842
16	SEE ER-842
17	SEE ER-842
18	SEE ER-842
19	SEE ER-842
20	SEE ER-842
21	SEE ER-842
22	SEE ER-842
23	SEE ER-842
24	SEE ER-842
25	SEE ER-842
26	SEE ER-842
27	SEE ER-842
28	SEE ER-842
29	SEE ER-842
30	SEE ER-842
31	SEE ER-842
32	SEE ER-842
33	SEE ER-842
34	SEE ER-842
35	SEE ER-842
36	SEE ER-842
37	SEE ER-842
38	SEE ER-842
39	SEE ER-842

CIRNO INORCO	PART NO	PART NAME
1	4024-C	PC BOARD
R1	10T60-3-2	RESISTOR 15K1/4W
R2	10T34-3-2	RESISTOR 15K1/4W
R3	10T5-3-2	RESISTOR 1801/4W
R4	10T000-3-2	RESISTOR 33K1/4W
R5	10T80-3-2	RESISTOR 10K1/4W
R7	10T00T-3-2	RESISTOR 3501/4W
8		
C743341	2-02M-0043	CAPACITOR .02-150
C2910	2-15P-0065	CAPACITOR .15P-150
C24	2-01M-0040	CAPACITOR .01M-150
C6	2-33P-0014	CAPACITOR 33P-150
C9	2-50P-0016	CAPACITOR 50P-150
C21	2-511-A	PISTON TRIMMER
C27	2-507-A	PISTON TRIMMER
16		
17		
18		
L1	3602-A	CHOKER 6.8uH
L2	3604-A	CHOKER 30uH
L5	3614-A	OSC COIL
22		
T3	3016-A	TRANSFORMER
24		
Q3	4749-A	TRANSISTOR 40B19
Q2	4748-A	TRANSISTOR 40B94
27		
28	24261-A	TUBING INSULATING (YELLOW)
29	24260-A	TUBING INSULATING (RED)
30	5425-A	SOCKET, TRANSISTOR
31	5483-A	SOLDER JG
32	7001	RG196U COAX
33	57D-2	WIRE, JUMPER (BW)
34		
35	2433-4-4	ORANGE
36	2444-4-4	YELLOW
C8	2-22P-0012	CAPACITOR 22 PF NPO
C2	2-10P-0011	CAPACITOR 10 PF NPO
39		

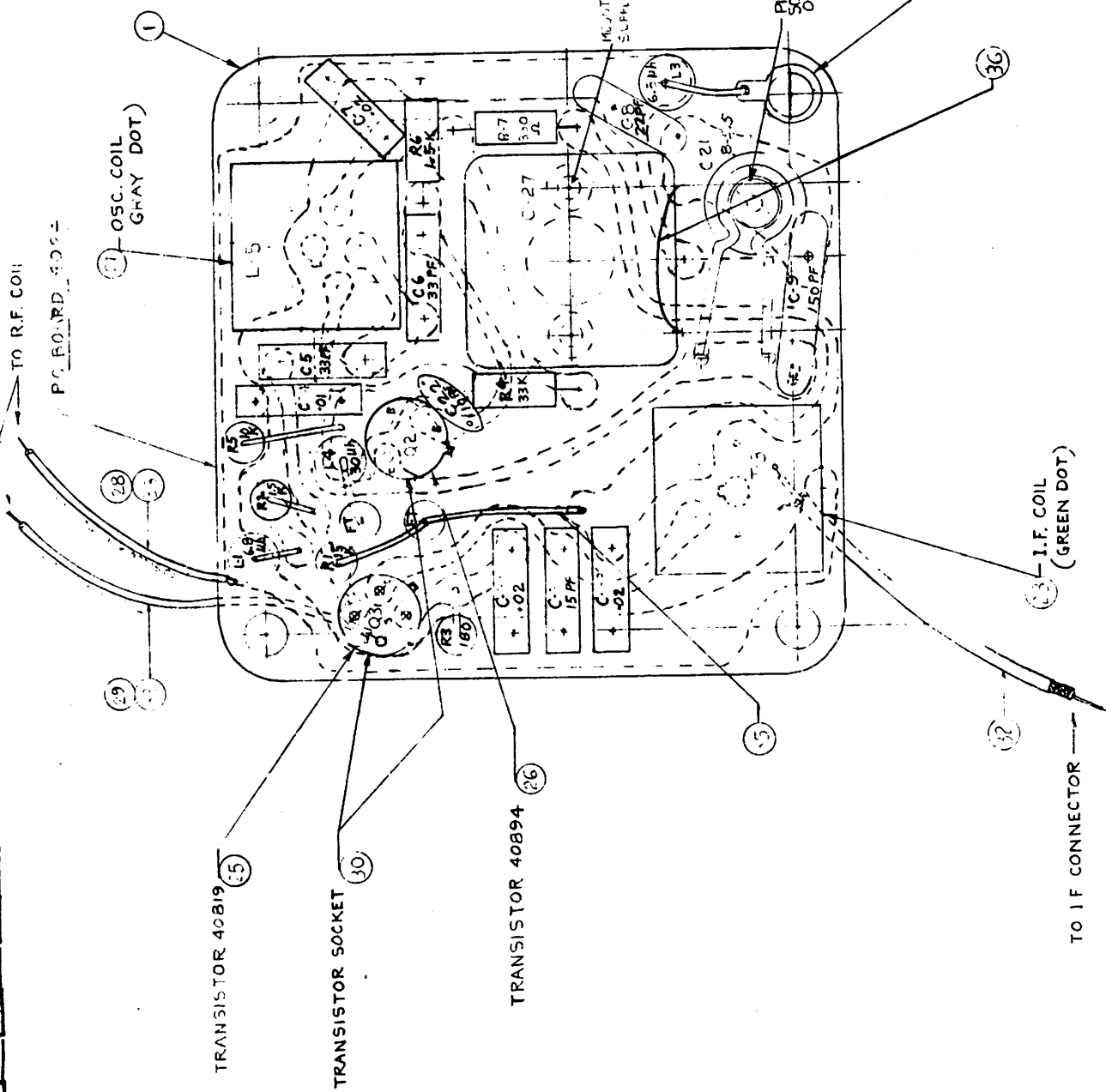
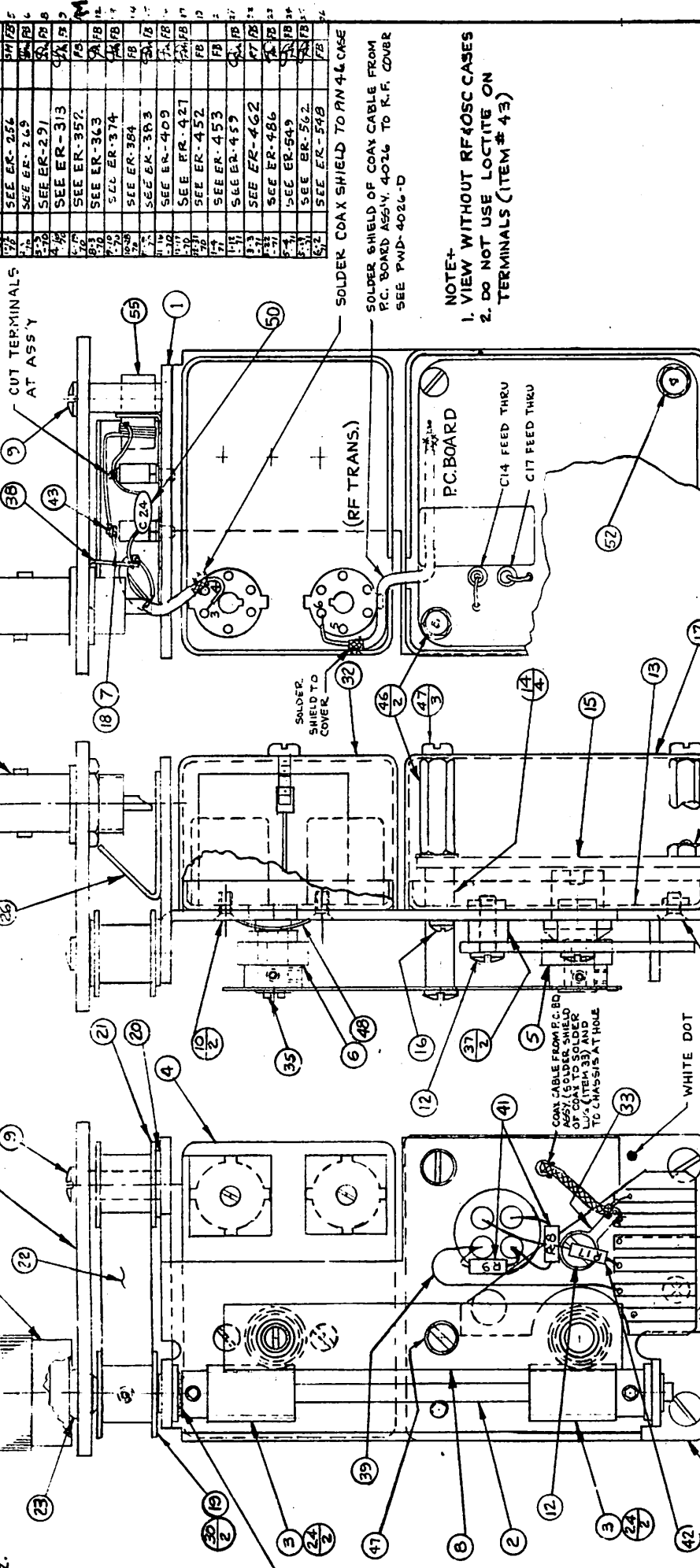

FIGURE 12.13

TOLERANCES (EXCEPT AS NOTED)	MASON ENGINEERING INC. 1700 POST RD. FAIRFIELD, CONN.
ORIGINAL	SCALE 4:1
REPRODUCTION	DATE 2/1/72
AMPLIFIED	BY 2/1/72
DATE	TITLE PICTORIAL WIRING DIAGRAM TA3-3
DATE	PWD 402

USED ON	
1 30120	

REV	DATE	DESCRIPTION	BY	CHK
1	7/10/54	SEE ER-381
2	7/10/54	SEE ER-203
3	7/10/54	SEE ER-451
4	7/10/54	SEE ER-216
5	7/10/54	SEE ER-234
6	7/10/54	SEE ER-252
7	7/10/54	SEE ER-256
8	7/10/54	SEE ER-269
9	7/10/54	SEE ER-313
10	7/10/54	SEE ER-357
11	7/10/54	SEE ER-363
12	7/10/54	SEE ER-374
13	7/10/54	SEE ER-384
14	7/10/54	SEE ER-383
15	7/10/54	SEE ER-409
16	7/10/54	SEE ER-421
17	7/10/54	SEE ER-452
18	7/10/54	SEE ER-453
19	7/10/54	SEE ER-457
20	7/10/54	SEE ER-462
21	7/10/54	SEE ER-486
22	7/10/54	SEE ER-549
23	7/10/54	SEE ER-562
24	7/10/54	SEE ER-548



NOTE: 1. LOCATE ITEM 34 OVER SCREW HEAD ITEM 16 & SOLDER ITEM 34 TO ITEM 1. 2. AFTER COMPLETION OF WIRING ITEM 34, TACK SOLDER CASE ITEM 57 TO ASSY.

NO	REV	DATE	DESCRIPTION	BY	CHK
58					
59					
60					
61					
62					
63					
64					
65					
66					
67					
68					

CIR NO	PART NO	PART NAME	CIR NO	PART NO	PART NAME
20	1754A	WASHER 1/16" DIA	29	2435-662	WIRE
21	1600A	SPECIAL WASH	40		
22	2300A	TAPE, DIAL CUT TO LENGTH	41	1001-32	RESISTOR 3200 1/4W 5%
23	1000A	BUSHING	42	10-YP32	RESISTOR 4.7K 1/4W 5%
24	2563-355	2-56X 1/8 SET SCREW	43	5440-A	TRIMMER
25	8014-A	KNURLED	44	18-21	NUT, HEX 1/4-40
26	24053-B	MILNUT	45	17514	WASHER 5/4 FLAT
27	30155A	PLAST WINDOW COMPL	46	13099A	SPACER
28	5603-A	CONNECTION BNC	47	44-8-66	SCREW 1/4-40X 1/2 PAN HD
29	17500A	WASHER BOWED	48	24-257A	WIPER
30	41048	SCREW SET	49	2-10P-0011	CAPACITOR 10 PF
31	2564-155	SCREW 1/8-32	50		
32	119-104	WASHER 1/8-32	51	17522-A	WASHER INTERNAL LOCK
33	5449-A	SOLDER LUG #4	52		
34			53		
35			54		
36			55		
37	13000A	SPACER 1/8"	56		

TE: TORQUE WRENCH TO EXCEED 1/2 OZ.

NOTE: 1. VIEW WITHOUT RF40SC CASES 2. DO NOT USE LOCTITE ON TERMINALS (ITEM # 43)

FIGURE 12.14

ER-100-P

MASON ENGINEERING INC. 1700 POST RD. FAIRFIELD, CONN. DRAWN BY ALS APPROVED BY PJB

NO	REV	DATE	DESCRIPTION	BY	CHK
1					
2					
3					
4					
5					
6					
7					
8					
9					
10					
11					
12					
13					
14					
15					
16					
17					
18					
19					
20					
21					
22					
23					
24					
25					
26					
27					
28					
29					
30					
31					
32					
33					
34					
35					
36					
37					
38					
39					
40					
41					
42					
43					
44					
45					
46					
47					
48					
49					
50					
51					
52					
53					
54					
55					
56					

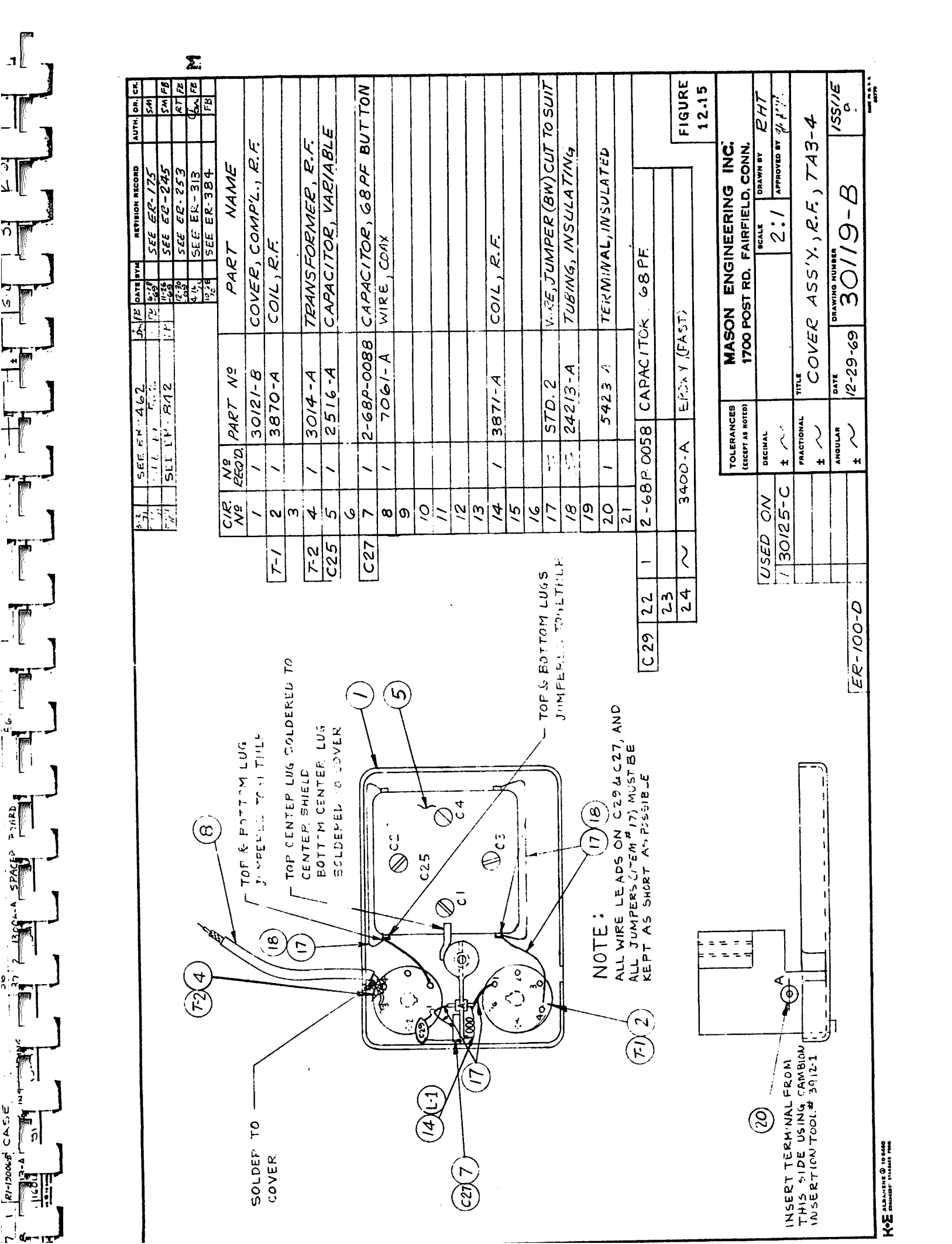

SOLDER TO COVER

TOP & BOTTOM LUG JUMPER TO SHIELD

TOP CENTER LUG SOLDERED TO COVER

CENTER SHIELD

BOTTOM CENTER LUG SOLDERED TO COVER

TOP & BOTTOM LUGS JUMPER TO SHIELD

NOTE:
ALL WIRE LEADS ON C29 & C27, AND ALL JUMPERS (ITEM # 17) MUST BE KEPT AS SHORT AS POSSIBLE

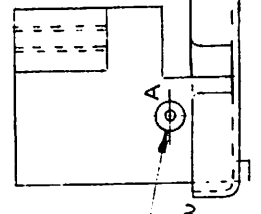

CIR. NO.	REV'D.	DATE	BY	REVISION RECORD	AUTH.	DR.	CR.
1	1	10-26-68	SM	SEE ER-175	SM		SM
2	1	11-26-68	SM	SEE EG-245	SM		SM
3	1	12-29-68	SM	SEE EG-253	SM		SM
4	1	1-11-69	SM	SEE ER-313	SM		SM
5	1	1-29-69	SM	SEE ER-384	SM		SM

CIR. NO.	REV'D.	PART NO.	PART NAME
1	1	30121-B	COVER, COMPL., R.F.
2	1	3870-A	COIL, R.F.
3			
4	1	3014-A	TRANSFORMER, R.F.
5	1	2516-A	CAPACITOR, VARIABLE
6			
7	1	2-68P-0088	CAPACITOR, 68PF BUTT ON
8	1	7061-A	WIRE, COAX
9			
10			
11			
12			
13			
14	1	3871-A	COIL, R.F.
15			
16			
17	1	STD. 2	WIRE, JUMPER (BW) CUT TO SUIT
18	1	24213-A	TUBING, INSULATING
19			
20	1	5423-A	TERMINAL, INSULATED
21			
C29	22	1	2-68P-0058 CAPACITOR 68PF.
	23		
	24	~	3400-A EMPTY (FAST)

FIGURE 12.15

TOLERANCES (EXCEPT AS NOTED)	SCALE	DRAWN BY	APPROVED BY
DECIMAL ± ~	2:1	RHT	RHT
FRACTIONAL ± ~			
ANGULAR ± ~			
USED ON	TITLE	DATE	DRAWING NUMBER
1 30125-C	COVER ASS'Y., R.F., TAB-4	12-29-69	30119-B
			ISSUE

MASON ENGINEERING INC. 1700 POST RD. FAIRFIELD, CONN.			
ER-100-D			

QTY	PART NO.	PART NAME
1	4026-C	P.C. BOARD AS MACHINED
2	5TD-2	WIRE JUMPER (6W)
3	5425-A	SOCKET TRANSISTOR
4	4723-A	TRANSISTOR 2N5181
5	4748-A	TRANSISTOR 40819-4
6	19085-A	COVER, COIL FORM
7	24215-A	TUBING, INSULATED
8	10-T50-32	RES-5TOR 18 K 1/4W 5/2
9	10-T80-51	RES-5TOR 10 K 1/4W 5/2
10	10-T68-51	RES-5TOR 15K 1/4W 5/2
11	10-T80-52	RES-5TOR 10K 1/4W 5/2
12	10-T80-52	RES-5TOR 10K 1/4W 5/2
13	10-T80-52	RES-5TOR 10K 1/4W 5/2
14	10-T80-52	RES-5TOR 10K 1/4W 5/2
15	10-T80-52	RES-5TOR 10K 1/4W 5/2
16		
17		
18	2-33R-004	RES-5TOR 33 PF
19	2-10R-001	RES-5TOR 10 PF
20	2-10R-001	RES-5TOR 10 PF
21	2-15P-005	RES-5TOR 15 PF
22	2-01M-00407	RES-5TOR 0.1M
23	2-100R-005	RES-5TOR 100 OHMS
24	2-01M-00407	RES-5TOR 0.1M
25	2-507A	CAPACITOR POLY-VARIABLE
26		
27		
28	3017-A	COIL, DSC. T43-4
29	5936-B	WIRE, DOUBLE BALANCED
30	5489-A	SOLDER LUG
31	7002-A	WIRE, COAX 24.14
32	7001-A	WIRE, COAX 2.14
33	3400-A	EPoxy (FAST)

TO R.F. AMPLIFIER (7-10-53)

WIRE CENTER CONDUCTOR OF COAXIAL CABLE TO C-19, SHIELD TO GROUND

LEAF FROM WLD

JUMPER WIRE THRU HOLES & SOLDER

DEF THE 4-SHORT ON SHIELD BEFORE FALLING

TO CONNECTOR BD

ISOLATE WITH SHRINKABLE TUBING LEADS SO THAT THEY NOT TOUCH SHIELD OF T-3

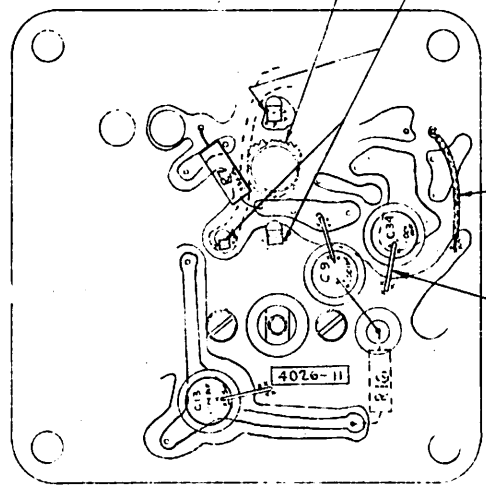

30 EPOXY T3 COIL FORM AT ASSY.

31 SOLDER TAB TO COPPER

32 MAKE JUMPER AS SHORT AS POSSIBLE

33 SPLICE WIRE TO GROUND TABS OF VARIABLE CAPACITOR (THIS IN C26 MAKE TOO SHORT TO MAKE SOLDER CONNECTION ON COPPER)

FIGURE 12.16

USED ON	QUANTITY	REVISION	DATE	BY	APPROVED BY
1	1	3-0125-C			

DESIGNED BY	DRAWN BY	CHECKED BY	DATE

PROJECT	DESCRIPTION	DATE
ES-100-C	PICTORIAL WIRING DIAGRAM T43-4	2-17-71

WAGON ENGINEERING INC.
1700 PORT RD. FAIRFIELD, CONN.

SCALE: 4:1

DATE: 5/1/75

BY: J.P.P.



7/1	SEE ER. 209
7/2	SEE ER. 216
7/3	SEE ER. 234
7/4	SEE ER. 248
7/5	SEE ER. 254
7/6	SEE ER. 291
7/7	SEE ER. 317
7/8	SEE ER. 328
7/9	SEE ER. 352
7/10	SEE ER. 358
7/11	SEE ER. 374
7/12	SEE ER. 412
7/13	SEE ER. 427
7/14	SEE ER. 451
7/15	SEE ER. 452
7/16	SEE ER. 486
7/17	SEE ER. 494
7/18	SEE ER. 549
7/19	SEE ER. 546
7/20	SEE ER. 548
7/21	SEE ER. 554
7/22	SEE ER. 700
7/23	SEE ER. 775
7/24	SEE ER. 776

THESE WIRES MUST BE DRESSED TO FIT THROUGH CASES R-19010 AND R-19008

FIGURE 12.17

A	T-2 ADJ
B	L-5 ADJ
C	L-4 ADJ
D	L-3 ADJ
E	C-170 ADJ
F	C-17A ADJ
G	C-16D ADJ
H	C-16A ADJ
J	L-1 ADJ
K	T-1 ADJ
L	C-3A ADJ
M	C-3D ADJ

FIGURE 12.17

TOLERANCES UNLESS OTHERWISE SPECIFIED	±.005
FRACTIONAL	2/64
ANGLES	2°
FINISH	2:1
PROCESSED BY	ALB
DATE	6-29-68
REV	27

MASON ENGINEERING INC.
1700 POST RD. FAIRFIELD, CONN.
DESIGNED BY
CHECKED BY

TUNER ASSY, TA3-5

30130-C

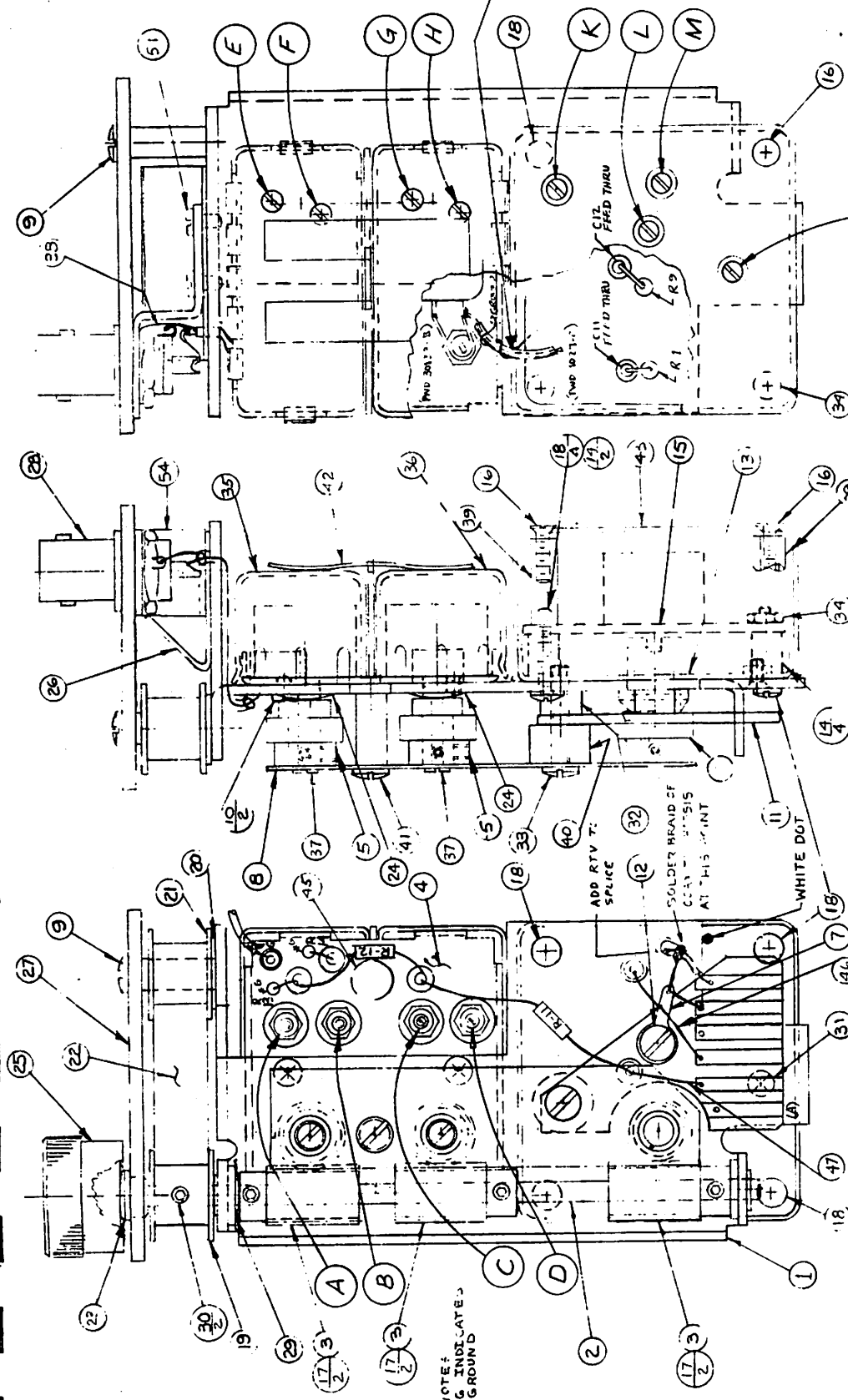

CIR. NO.	PART NO.	PART NAME	QTY	REF. NO.	DESCRIPTION
1	30131-A	BRACKET COMPL. MNG	20	1754/A	WASHER
2	1501-A	SHAFT, MAIN	21	1600-A	SPOOL IDLER
3	9002-A	WORM	22	2300-A	TAME DIAL
4	100133-B	COVER ASSY R.F.	23	10000-A	BUSHING
5	10192-A	DRIVE GEAR ASSY	24	14257A	WIPER
6	30193-A	DRIVE GEAR ASSY	25	8014-A	KNOB
7	15423-A	PLATE, GEAR	26	24032-A	PLATE
8	24011A	PLATE, GEAR	27	1011-A	PLATE WINDOW COIL
9	14018-A	SCREW #4-40 x 1/8 (CRUM)	28	15663-A	CONNECTOR BNC
10	254-4-65	SCREW #2-56 PAN HD	29	17500-A	WASHER, BOUYED
11	4022-A	BOARD, CONNECTOR	30	14049-35	SCREW, BUSH
12	40126-B	SCREW #4-40 x 3/8 PH	31	25647-MS	SCREW #2-56 FLT HD
13	32177-A	CLIP, OSC	32	13006-A	SPACER, BOARD
14	13002A	SPACER	33	14011-A	SCREW, 4-40 x 5/8
15	13002A	SPACER	34	18000	NUT
16	25410-MS	SCREW #2-56 x 3/16 FH	35	19009-B	CASE, R.F. (TOP)
17	25410-MS	SCREW #2-56 x 3/16 FH	36	19010-B	CASE, R.F. (BOTTOM)
18	25410-MS	SCREW #2-56 x 3/16 FH	37	19011-B	CASE, R.F. (BOTTOM)
19	14001-A	SPOOL, DRIVE	38	14001-A	SPOOL, DRIVE

4718-A J RANGE DIAL 40894 Q3
24-33-4-3/4 WIRE #24 3/4 LG
24-33-4-3/4 WIRE #24 1/2 LG
10-001-3 RESISTOR 32 1/2 W 1/4 A R-11 R-14
10-001-3 RESISTOR 39 1/2 W 1/4 A R-12
10-001-3 RESISTOR 39 1/2 W 1/4 A R-12
28-56-50 SCREW 2-56 PAN HD 3/16 LG

USED ON
1 30100

DATE	BY	REVISION	RECORD	AUTH.	DR.	CR.
12/16/69	SEE ER-248	SEE ER-248			AT/FB	
1/2/70	SEE ER-318	SEE ER-318			SH/FB	
7/70	SEE ER-348	SEE ER-348			SH/FB	
7/74	SEE ER-408	SEE ER-408			SH/FB	
9/71	SEE ER-508	SEE ER-508			SH/FB	

CIR.	REQ.	PART NO.	PART NAME
1	1	3024-B	COVER R.F. COMPL.
2	2	2521-A	MITSUMI PVC-2Z
3	1	7002-A	MINIATURE COAX, 2/4"
4	1	5423-A	TERMINAL INSULATED
5	3	300 P. 0029	CAP. FEEDTHRU 1000 P.F.
6	1	5422-A	SOCKET, TRANSISTOR
7	1	10-300-2	RESISTOR 39 K Ω 1/4W
8	1	10-300-2	RESISTOR 330 Ω 1/4W
9	1	10-300-2	RESISTOR 3.9 K Ω 1/4W
10	1	TRANSFORMER	SP/45 W24
11	1	3837-A	LIMC COIL #2 IT #26
12	1	3834-A	COIL, 47 # 26 CW
13	1	3832-A	COIL, 47 # 26 CCW
14	1	STD-2	JUMPER (BWN) 1/2 L9
15	1	3206-A	CORE, COIL (GREEN)
16	1	3223-A	CORE, COIL (WHITE)
17	1		
18	1		
19	1		
20	1		

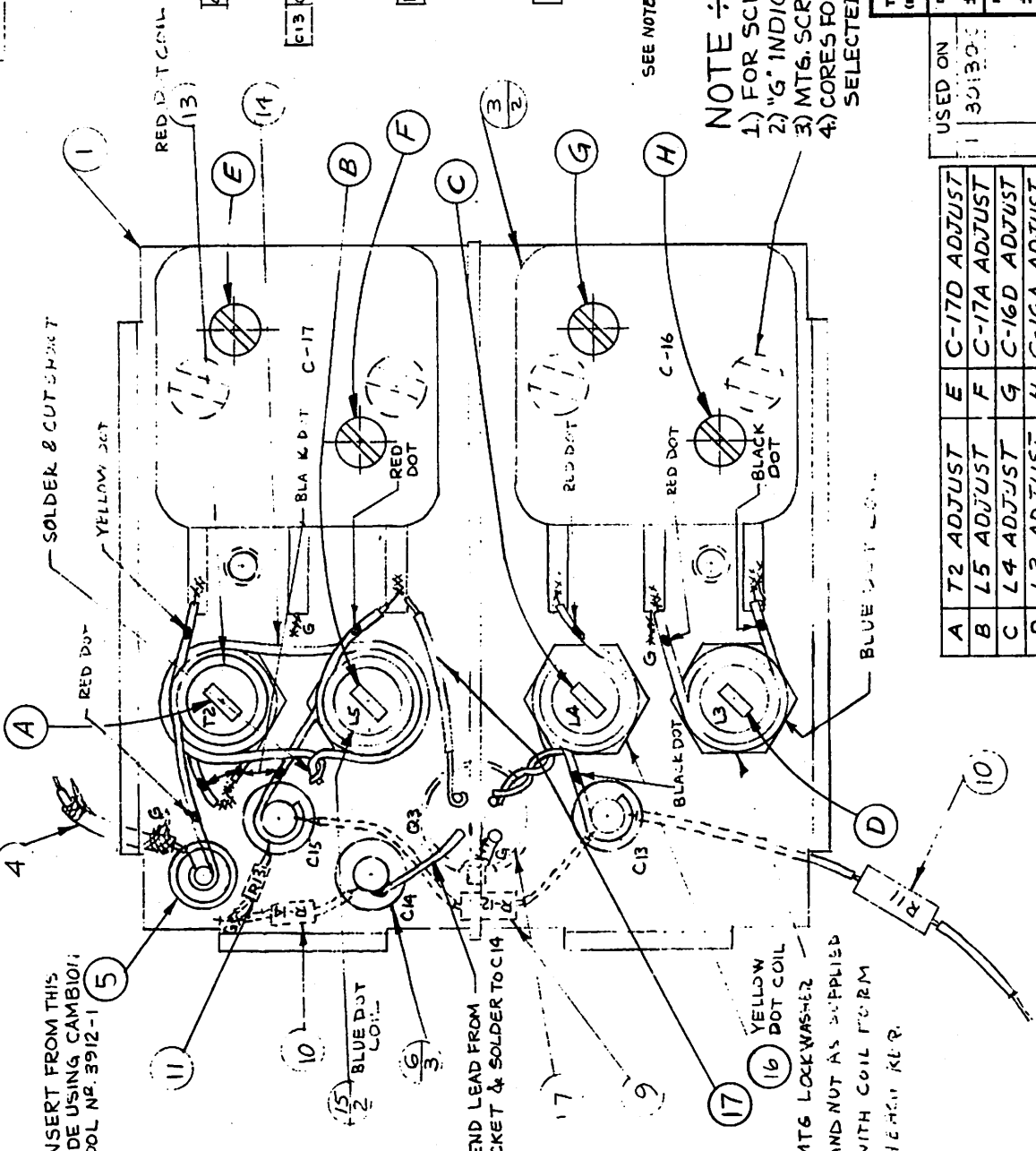

NOTE 4

- NOTE 1) FOR SCHEMATIC SEE SWD-4017-B
 2) "G" INDICATES CHASSIS GROUND CONNECTION
 3) MTG. SCREWS AS SUPPLIED WITH PART 3 (4RD.)
 4) CORES FOR L3, L4, L5 & L2 ARE FACTORY SELECTED (GREEN MEI 3206-A OR WHITE MEI 3223-A)

TOLERANCES (EXCEPT AS NOTED)	ORIGINAL	SCALE	DRAWN BY
	±	4:1	SPM.
FRACTIONAL	±	TITLE	COVER ASSY R.F. TAB-5
ANGULAR	±	DATE	9-30-68
		DRAWING NUMBER	PWD-30133-B
		ISSUE	7

USED ON	ORIGINAL	SCALE	DRAWN BY
1	30130-B	4:1	SPM.

ADJUST	ADJUST	ADJUST	ADJUST
A T2 ADJUST	E C-17D ADJUST	F C-17A ADJUST	G C-16D ADJUST
B L5 ADJUST	F C-17A ADJUST	G C-16D ADJUST	H C-16A ADJUST
C L4 ADJUST	G C-16D ADJUST	H C-16A ADJUST	
D L3 ADJUST	H C-16A ADJUST		

1	SEE ER-159
2	SEE ER-166
3	SEE ER-176
4	SEE ER-209
5	SEE ER-248
6	SEE ER-700
7	SEE ER-700
8	SEE ER-700
9	SEE ER-700
10	SEE ER-700
11	SEE ER-700
12	SEE ER-700
13	SEE ER-700
14	SEE ER-700
15	SEE ER-700
16	SEE ER-700
17	SEE ER-700
18	SEE ER-700
19	SEE ER-700
20	SEE ER-700
21	SEE ER-700
22	SEE ER-700
23	SEE ER-700
24	SEE ER-700
25	SEE ER-700
26	SEE ER-700
27	SEE ER-700
28	SEE ER-700
29	SEE ER-700
30	SEE ER-700

CIR. NO.	REF. NO.	PART NO.	PART NAME
R-1	1	10-00R-3-2	RESISTOR 3.3K 1/4W
R-2	2	10-R80-3-2	RESISTOR 20K 1/4W
R-3	3	10-T80-3-2	RESISTOR 10K 1/4W
R-4	4	10-T6R-3-2	RESISTOR 1.5K 1/4W
R-5	5	10-T60-3-2	RESISTOR 15K 1/4W
R-6	6	10-T5T-3-2	RESISTOR 180 1/4W
R-7	7	10-00T-3-2	RESISTOR 330 1/4W
R-8	8	10-00M-0040	CAPACITOR .01M
C-1	1	2-33 P-0014	CAPACITOR 33P
C-2	2	2-507-A	CAPACITOR, MITSUBI MC-32
C-3	3	2-120P-0092	CAPACITOR 120 P
C-4	4	2-02M-0043	CAPACITOR .02M
C-5	5	2-50P-0133	CAPACITOR 50P
C-6	6	2-23P-0012	CAPACITOR 23P
C-7	7	3019-A	TRANSFORMER, I F
L-1	1	3839	COIL, OSC
L-2	2	3602	CHOKE, 6.8 MH.
Q-1	1	4748-A	TRANSISTOR, 40894
Q-2	2	4749-A	TRANSISTOR, 40819
Q-3	3	5425-A	SOCKETS, Q1, Q2
Q-4	4	5487-A	SOLDER LUG
J-1	1	STD-2	JUMPER (BW) 7/8x1/4
J-2	2	7004	COAX, RG 196(1/4, 3")
J-3	3	4027-B	PC BOARD AS MACH T3-5
J-4	4	STD-2	JUMPER (BW) 1" LG
J-5	5	STD-2	JUMPER (BW) 2" LG
J-6	6	STD-2	JUMPER (BW) 2" LG
J-7	7	24075-A	TUBING, INSULATED 1/2"
J-8	8	24054-A	TUBING, INSULATED 3/8"
J-9	9	24070-A	TUBING, INSULATED 3/4"

NOTE -
 1 ADD COATING OF BETA-COTE CLEAR #91-18 TO BOTH SIDES OF P-CBOARD AT ASSEMBLY (ESSEX CHEMICAL, NEW JERSEY)

FIGURE 12.19

TOLERANCES (EXCEPT AS NOTED)	MASON ENGINEERING INC. 1700 POST RD. FAIRFIELD, CONN.
DRAWING	SCALE 4:1 DRAWN BY SPM APPROVED BY [Signature]
TITLE	PICTORIAL WIRING DIAGRAM T3-5
DATE	S-23-69
ISSUE	PWD 4027-C 8

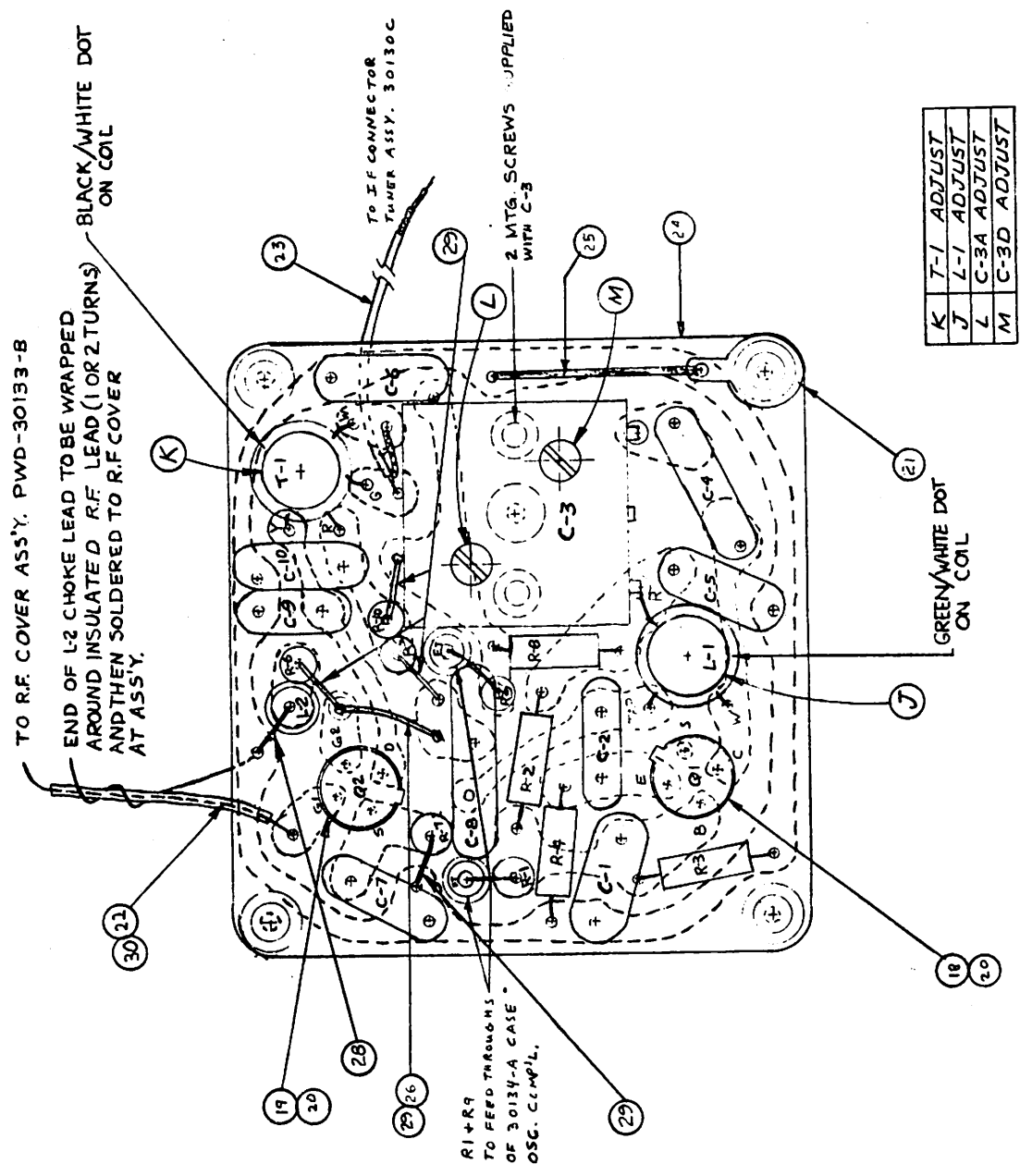

K	T-1 ADJUST
J	L-1 ADJUST
L	C-3A ADJUST
M	C-3D ADJUST

1	30156-D	CHASSIS COMPT'L
2	30156-B	BROCKET COMPT' NYS
3	400-P-18-S	SCREW # 4-40 X 1/4" HD
4	30143-A	DRIVE GEAR COMPT'L
5	18071-A	SPROCKET DRIVE
6	440-4-5-S	SCREW SET
7	23008-A	TAPE DIA
8	16000-A	SPOON ADJER
9	440-P-18-S	SCREW # 4-40 PH RD
10	255-4-4-S	SCREW # 2-56 PH RD
11	400-4-4-S	SCREW # 3-48 PH RD
12	24056-B	MIRROCK

13	5423-A	TERMINAL INSULATED
14	10030-A	BUSHINGS
15	8016-A	KNOB
16	5439-A	SOLDER LUS
17	5513-A	CONNECTOR, DMC
18	2005-A	KNOB, BALL
19	256-4-4-S	SCREW # 2-56 PH RD
20	30175-A	SWITCH ARM COMPT'L
21	17005-A	RETAINING RING
22	255-4-4-S	SCREW # 2-56 PH RD
23	4005-B	CONNECTOR BR
24	2423A	TUBINS INSULATED
25	5035-B	BALANCED WHEEL
26	2423A	TUBINS INSULATED
27	5035-B	BALANCED WHEEL
28	2423A	TUBINS INSULATED
29	5035-B	BALANCED WHEEL
30	5018-A	PLATE WINDOW COMD
31	7021-A	COIL 250 UH
32	7021-A	COIL 476 UH
33	5450A	TERMINAL INSULATED
34	255-4-4-S	SCREW # 2-56 PH RD
35	4005-B	CONNECTOR BR
36	255-4-4-S	SCREW # 2-56 PH RD
37	255-4-4-S	SCREW # 2-56 PH RD
38	255-4-4-S	SCREW # 2-56 PH RD
39	2423A	TUBINS INSULATED
40	2423A	TUBINS INSULATED
41	2423A	TUBINS INSULATED
42	2423A	TUBINS INSULATED
43	2423A	TUBINS INSULATED
44	2423A	TUBINS INSULATED
45	2423A	TUBINS INSULATED
46	2423A	TUBINS INSULATED
47	2423A	TUBINS INSULATED
48	2423A	TUBINS INSULATED
49	2423A	TUBINS INSULATED
50	2423A	TUBINS INSULATED

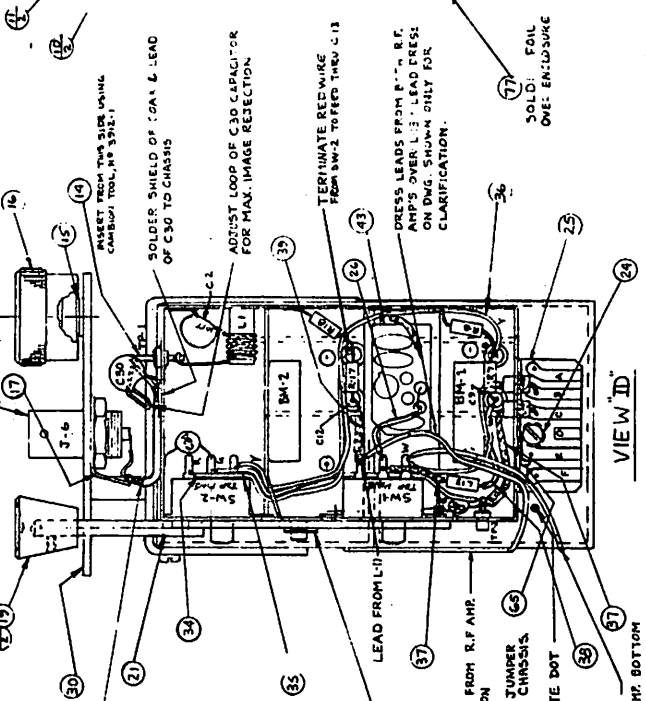
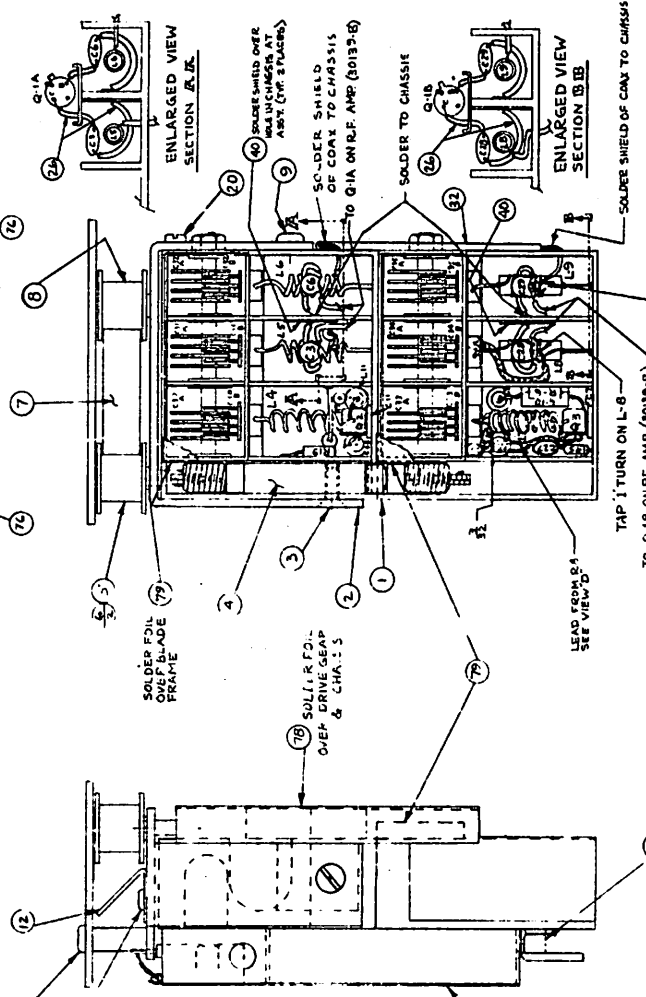
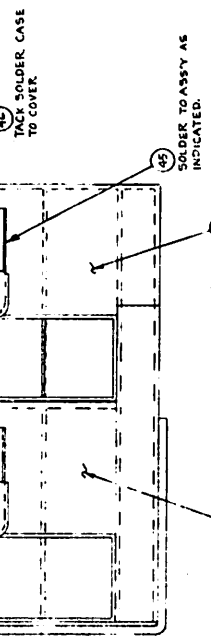
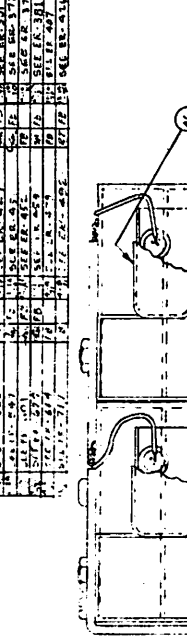

NOTE #

- FOR SCHEMATIC WIRING DIAGRAM, SEE SWD-4018-B
- ALL WIRES TO P-1 SHOULD BE LOOPED FOR SLACK BEFORE SOLDERING

NOTE #

3) # INDICATES FACTORY SELECTED VALUE

C14	CO	1	P-47	100	0.001	0.5	5			
C30	C27	57	2	2	0.001	0.5	5			
C30	C6	C3	5P	4	2-200-002	CAPACITOR	120 PF			
C30	C28	C7	5P	4	2-200-002	CAPACITOR	120 PF			
C24	C22	C13	C12	C9	C8	5P	4	2-200-002	CAPACITOR	120 PF
C25	C24	C11	C7	5P	4	2-200-002	CAPACITOR	120 PF		
C25	C24	C11	C7	5P	4	2-200-002	CAPACITOR	120 PF		
C25	C24	C11	C7	5P	4	2-200-002	CAPACITOR	120 PF		
C25	C24	C11	C7	5P	4	2-200-002	CAPACITOR	120 PF		

L1	L12	L11	L10	L9	L8	L7	L6	L5	L4	L3	L2	L1
61	1	1	1	1	1	1	1	1	1	1	1	1
1	1	1	1	1	1	1	1	1	1	1	1	1

SHOWN TO UPPER SECTION & CONTACTS OF 2 SLIDE SWITCHES

FIGURE 12.20

TUNER 10-11-48 30

ER-100-R

DATE	BY	REVISION	RECORDED	AUTH.	OR	CEL
12/1		SEE ER-509				1/78
12/1		SEE ER-700				12/78

CIR NO	REQ	PART NO	PART NAME			
1	1	4068-A	P.C. BOARD (AS MACH)			
R-11	2	10-0WR-2-2	RESISTOR 39K			
R-12	3	10-0W0-2-2	RESISTOR 39K			
R-13	4	10-00T-2-2	RESISTOR 330Ω			
	5					
	6					
Q-10	7	4748-A	TRANSISTOR 40894			
	8					
	9	24213-A	INSULATING SLEEVE			
G-23	G-21	G-20	10	3	2-1000P-0003	CAPACITOR .001 MF
			11			
L-21	12	1	3607-A	CHOKE		
	13	1	STD-2	WIRE JUMPER (BW)		
R-10	14	10-TBR-2	RESISTOR 1K			

FIGURE 12.21

NOTE :-

- INSULATING SLEEVE ON LEAD OF TRANSISTOR $\frac{1}{8}$ LG. TERMINATE TO COPPER LAND OF R11
- MOUNT TRANSISTOR LAST ON ASSY.

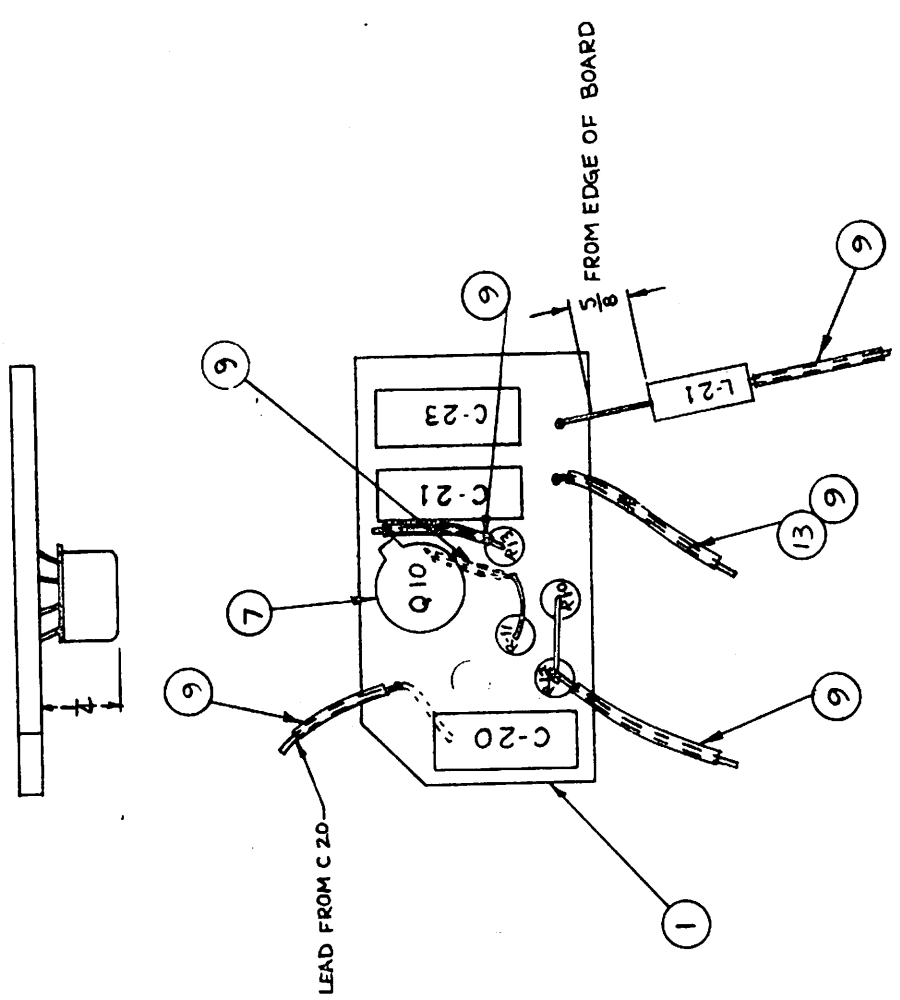

USED ON	TOLERANCES (EXCEPT AS NOTED)	MASON ENGINEERING INC.
1 30135-D	DECIMAL ±	1700 FAIRFIELD, CONN.
	FRACTIONAL ±	SCALE 4:1
	ANGULAR ±	DRAWN BY 3/1/78
		APPROVED BY
		TITLE I.F. PREAMP ASSY TA3-6
		DRAWING NUMBER PWD-4068-B
		ISSUE 3

ER-381

THIS JOINT IS NOT SOLDERED TO BUTTON CAPACITOR

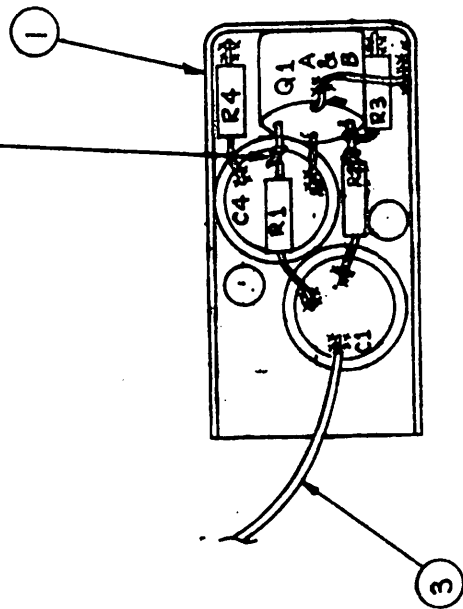

DATE	REVISION RECORD	AUTH	OR
12-10-50	SEE ER-381		FD
12-10-50	SEE ER-476		
12-10-50	SEE ER-151		

CIR. NO.	NO. REQD.	PART NO.	PART NAME
1	1	R-19078-A	COVER, R.F. AMP.
2			
3	1	24-22-4-4-5	WIRE, LEAD (R) 5" LG.
4	1	4723-A	TRANSISTOR 2N5101
5			
6	2	2-1000R-0001	CAPACITOR .001
7			
8			
9			
10	1	10-TBR-2-2	RESISTOR 1K 1/8W
11	1	10-R80-2-2	RESISTOR 20K
12	1	10-00R-2-2	RESISTOR 3.3K
13	1	10-00T-2-2	RESISTOR 330Ω 1/8W
14			

Q-18	C-1A
C-4	C-1
R-1	R-1
R-2	R-2
R-3	R-3
R-4	R-4

12.22

NOTE: FOR SCHEMATIC INFORMATION SEE SWD-4028-C

FIGURE 12.22

USED ON	TOLERANCES (EXCEPT AS NOTED)	MASON ENGINEERING INC. 1700 POST RD. FAIRFIELD, CALIF.
2 30135-D	DECIMAL ± .005	SCALE 4:1
	FRACTIONAL ± 1/64	DRAWN BY SPM.
	ANGULAR ± 1°	APPROVED BY
	TITLE	R.F. AMP. COMP'L.
	DATE	10-30-70
	DRAWING NUMBER	30139-B
	ISSUES	5

ER-381

RIVET OVER AT ASS'Y.
 USE CAMBION TOOLS
 ANVIL N^o PSA-29 (G429)
 ROLLING PUNCH N^o PSP-29 (G629)

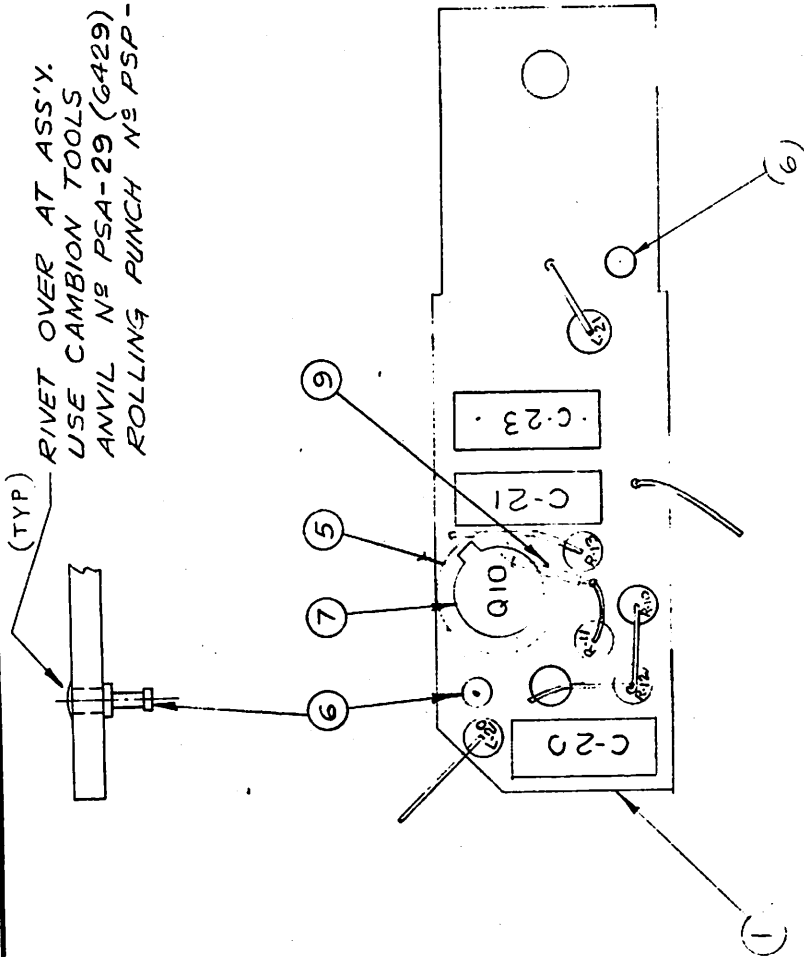

SEE NOTE N^o 3

DATE	BY	REVISION RECORD	AUTH.	DR.	CHK.
1/14/54	SAE	61-240			SAE
1/15/54	SEE ER-292				EMFB
1/16/54	SEE ER-100				RTF

CIR. NO.	REF.	PART NO.	PART NAME
1		4029	P-CERAMIC (ASMA)
R11	2	10-0W-32	RESISTOR 30K
R12	3	10-0W-0-3	RESISTOR 30K
R13	4	10-0W-32	RESISTOR 30K
5		5425-A	SOAK
6		5430-A	TERMINAL
Q10	7	4748-A	TRANS. 40894
L-20	8	3615-A	CHOKE 500MH
9		24000-A	INSULATOR
C-20	10	2-10-AP-010	CAPACITOR 100MF
11			
L-21	12	3607-A	CHOKE
13		STD-2	WIRE JUMPER 3W
R10	14	10-TBK-32	RESISTOR 1K

NOTE

- 1) IN THE AREA SHOWN ON LEAD OF R11 (C-20) PLACE PUNCH AND RIVET OVER AT ASS'Y.
- 2) ADD COATING OF PASTE NOTE #91-18 TO EXPOSED SURFACE OF PINS ON BOARD.
- 3) L-20 IS OMITTED ON TAB 7.

FIGURE 12.24

USED ON	TOLERANCES (EXCEPT AS NOTED)	MANUFACTURED BY	INC.
130140 D	DECIMAL	100% P.P.H.	MONTE
130150 L	FRACTIONAL ± 1/100	AD. 3	SCALE 4:1
	ANGULAR ± 1°	DRAWING NUMBER	APPROVED BY
		DATE 2-6-60	15
		TITLE I.E. PREAMP	DRAWING NUMBER PWD-4029 B 4

ER-100-6

REV	DATE	DESCRIPTION
1	10/10/53	INITIAL DESIGN
2	11/10/53	REVISED TO ACCORD WITH MIL-STD-883C
3	12/15/53	REVISED TO ACCORD WITH MIL-STD-883C
4	1/10/54	REVISED TO ACCORD WITH MIL-STD-883C
5	2/10/54	REVISED TO ACCORD WITH MIL-STD-883C
6	3/10/54	REVISED TO ACCORD WITH MIL-STD-883C
7	4/10/54	REVISED TO ACCORD WITH MIL-STD-883C
8	5/10/54	REVISED TO ACCORD WITH MIL-STD-883C
9	6/10/54	REVISED TO ACCORD WITH MIL-STD-883C
10	7/10/54	REVISED TO ACCORD WITH MIL-STD-883C
11	8/10/54	REVISED TO ACCORD WITH MIL-STD-883C
12	9/10/54	REVISED TO ACCORD WITH MIL-STD-883C
13	10/10/54	REVISED TO ACCORD WITH MIL-STD-883C
14	11/10/54	REVISED TO ACCORD WITH MIL-STD-883C
15	12/10/54	REVISED TO ACCORD WITH MIL-STD-883C
16	1/10/55	REVISED TO ACCORD WITH MIL-STD-883C
17	2/10/55	REVISED TO ACCORD WITH MIL-STD-883C
18	3/10/55	REVISED TO ACCORD WITH MIL-STD-883C
19	4/10/55	REVISED TO ACCORD WITH MIL-STD-883C
20	5/10/55	REVISED TO ACCORD WITH MIL-STD-883C
21	6/10/55	REVISED TO ACCORD WITH MIL-STD-883C
22	7/10/55	REVISED TO ACCORD WITH MIL-STD-883C
23	8/10/55	REVISED TO ACCORD WITH MIL-STD-883C
24	9/10/55	REVISED TO ACCORD WITH MIL-STD-883C
25	10/10/55	REVISED TO ACCORD WITH MIL-STD-883C
26	11/10/55	REVISED TO ACCORD WITH MIL-STD-883C
27	12/10/55	REVISED TO ACCORD WITH MIL-STD-883C
28	1/10/56	REVISED TO ACCORD WITH MIL-STD-883C
29	2/10/56	REVISED TO ACCORD WITH MIL-STD-883C
30	3/10/56	REVISED TO ACCORD WITH MIL-STD-883C
31	4/10/56	REVISED TO ACCORD WITH MIL-STD-883C
32	5/10/56	REVISED TO ACCORD WITH MIL-STD-883C
33	6/10/56	REVISED TO ACCORD WITH MIL-STD-883C
34	7/10/56	REVISED TO ACCORD WITH MIL-STD-883C
35	8/10/56	REVISED TO ACCORD WITH MIL-STD-883C
36	9/10/56	REVISED TO ACCORD WITH MIL-STD-883C
37	10/10/56	REVISED TO ACCORD WITH MIL-STD-883C
38	11/10/56	REVISED TO ACCORD WITH MIL-STD-883C
39	12/10/56	REVISED TO ACCORD WITH MIL-STD-883C
40	1/10/57	REVISED TO ACCORD WITH MIL-STD-883C
41	2/10/57	REVISED TO ACCORD WITH MIL-STD-883C
42	3/10/57	REVISED TO ACCORD WITH MIL-STD-883C
43	4/10/57	REVISED TO ACCORD WITH MIL-STD-883C
44	5/10/57	REVISED TO ACCORD WITH MIL-STD-883C
45	6/10/57	REVISED TO ACCORD WITH MIL-STD-883C
46	7/10/57	REVISED TO ACCORD WITH MIL-STD-883C
47	8/10/57	REVISED TO ACCORD WITH MIL-STD-883C
48	9/10/57	REVISED TO ACCORD WITH MIL-STD-883C
49	10/10/57	REVISED TO ACCORD WITH MIL-STD-883C
50	11/10/57	REVISED TO ACCORD WITH MIL-STD-883C
51	12/10/57	REVISED TO ACCORD WITH MIL-STD-883C
52	1/10/58	REVISED TO ACCORD WITH MIL-STD-883C
53	2/10/58	REVISED TO ACCORD WITH MIL-STD-883C
54	3/10/58	REVISED TO ACCORD WITH MIL-STD-883C
55	4/10/58	REVISED TO ACCORD WITH MIL-STD-883C
56	5/10/58	REVISED TO ACCORD WITH MIL-STD-883C
57	6/10/58	REVISED TO ACCORD WITH MIL-STD-883C
58	7/10/58	REVISED TO ACCORD WITH MIL-STD-883C
59	8/10/58	REVISED TO ACCORD WITH MIL-STD-883C
60	9/10/58	REVISED TO ACCORD WITH MIL-STD-883C
61	10/10/58	REVISED TO ACCORD WITH MIL-STD-883C
62	11/10/58	REVISED TO ACCORD WITH MIL-STD-883C
63	12/10/58	REVISED TO ACCORD WITH MIL-STD-883C
64	1/10/59	REVISED TO ACCORD WITH MIL-STD-883C
65	2/10/59	REVISED TO ACCORD WITH MIL-STD-883C
66	3/10/59	REVISED TO ACCORD WITH MIL-STD-883C
67	4/10/59	REVISED TO ACCORD WITH MIL-STD-883C
68	5/10/59	REVISED TO ACCORD WITH MIL-STD-883C
69	6/10/59	REVISED TO ACCORD WITH MIL-STD-883C
70	7/10/59	REVISED TO ACCORD WITH MIL-STD-883C
71	8/10/59	REVISED TO ACCORD WITH MIL-STD-883C
72	9/10/59	REVISED TO ACCORD WITH MIL-STD-883C
73	10/10/59	REVISED TO ACCORD WITH MIL-STD-883C
74	11/10/59	REVISED TO ACCORD WITH MIL-STD-883C
75	12/10/59	REVISED TO ACCORD WITH MIL-STD-883C
76	1/10/60	REVISED TO ACCORD WITH MIL-STD-883C
77	2/10/60	REVISED TO ACCORD WITH MIL-STD-883C
78	3/10/60	REVISED TO ACCORD WITH MIL-STD-883C
79	4/10/60	REVISED TO ACCORD WITH MIL-STD-883C
80	5/10/60	REVISED TO ACCORD WITH MIL-STD-883C
81	6/10/60	REVISED TO ACCORD WITH MIL-STD-883C
82	7/10/60	REVISED TO ACCORD WITH MIL-STD-883C
83	8/10/60	REVISED TO ACCORD WITH MIL-STD-883C
84	9/10/60	REVISED TO ACCORD WITH MIL-STD-883C
85	10/10/60	REVISED TO ACCORD WITH MIL-STD-883C
86	11/10/60	REVISED TO ACCORD WITH MIL-STD-883C
87	12/10/60	REVISED TO ACCORD WITH MIL-STD-883C
88	1/10/61	REVISED TO ACCORD WITH MIL-STD-883C
89	2/10/61	REVISED TO ACCORD WITH MIL-STD-883C
90	3/10/61	REVISED TO ACCORD WITH MIL-STD-883C
91	4/10/61	REVISED TO ACCORD WITH MIL-STD-883C
92	5/10/61	REVISED TO ACCORD WITH MIL-STD-883C
93	6/10/61	REVISED TO ACCORD WITH MIL-STD-883C
94	7/10/61	REVISED TO ACCORD WITH MIL-STD-883C
95	8/10/61	REVISED TO ACCORD WITH MIL-STD-883C
96	9/10/61	REVISED TO ACCORD WITH MIL-STD-883C
97	10/10/61	REVISED TO ACCORD WITH MIL-STD-883C
98	11/10/61	REVISED TO ACCORD WITH MIL-STD-883C
99	12/10/61	REVISED TO ACCORD WITH MIL-STD-883C
100	1/10/62	REVISED TO ACCORD WITH MIL-STD-883C

QTY	PART NO.	PART NAME	REV
1	1014-A	BRACKET COMB. MTR.	
2	1015-A	CHASSIS WIRE COMPR.	
3	1021-A	WASHER	
4	1022-A	SCREW 1/4" X 1/4" L.F.	
5	1023-A	SCREW 3/16" X 1/4" L.F.	
6	1024-A	SCREW 1/4" X 1/4" L.F.	
7	1300-A	DRIVE GEAR COMPL.	
8	1041-A	DRIVE GEAR COMPL.	
9	1042-A	SCREW 1/4" X 1/4" L.F.	
10	1043-A	SCREW 1/4" X 1/4" L.F.	
11	1044-A	SCREW 1/4" X 1/4" L.F.	
12	16001	SPOOL DRIVE	
13	16000	SPOOL IDLER	
14	1721-A	WASHER 1/4" X 1/4" L.F.	
15	1722-A	SCREW 1/4" X 1/4" L.F.	
16	1723-A	SCREW 1/4" X 1/4" L.F.	
17	8014-A	ANOD	
18	5624-A	CONNECTOR COM	
19	5454-A	SOLDER W/9	
20	10000	BUSHING	
21	1904-A	COVER SWAY	
22	4816-A	BOARD CHINCH	
23	1904-A	PC BOARD ASSY	
24	1904-A	COVER FILER	
25	1904-A	COVER PER	
26	1904-A	COVER PER	
27	1904-A	COVER PER	
28	1904-A	COVER PER	
29	1904-A	COVER PER	
30	1904-A	COVER PER	
31	1904-A	COVER PER	
32	1904-A	COVER PER	
33	1904-A	COVER PER	
34	1904-A	COVER PER	
35	1904-A	COVER PER	
36	1904-A	COVER PER	
37	1904-A	COVER PER	
38	1904-A	COVER PER	
39	1904-A	COVER PER	
40	1904-A	COVER PER	
41	1904-A	COVER PER	
42	1904-A	COVER PER	
43	1904-A	COVER PER	
44	1904-A	COVER PER	
45	1904-A	COVER PER	
46	1904-A	COVER PER	
47	1904-A	COVER PER	
48	1904-A	COVER PER	
49	1904-A	COVER PER	
50	1904-A	COVER PER	
51	1904-A	COVER PER	
52	1904-A	COVER PER	
53	1904-A	COVER PER	
54	1904-A	COVER PER	
55	1904-A	COVER PER	
56	1904-A	COVER PER	
57	1904-A	COVER PER	
58	1904-A	COVER PER	
59	1904-A	COVER PER	
60	1904-A	COVER PER	
61	1904-A	COVER PER	
62	1904-A	COVER PER	
63	1904-A	COVER PER	
64	1904-A	COVER PER	
65	1904-A	COVER PER	
66	1904-A	COVER PER	
67	1904-A	COVER PER	
68	1904-A	COVER PER	
69	1904-A	COVER PER	
70	1904-A	COVER PER	
71	1904-A	COVER PER	
72	1904-A	COVER PER	
73	1904-A	COVER PER	
74	1904-A	COVER PER	
75	1904-A	COVER PER	
76	1904-A	COVER PER	
77	1904-A	COVER PER	
78	1904-A	COVER PER	
79	1904-A	COVER PER	
80	1904-A	COVER PER	
81	1904-A	COVER PER	
82	1904-A	COVER PER	
83	1904-A	COVER PER	
84	1904-A	COVER PER	
85	1904-A	COVER PER	
86	1904-A	COVER PER	
87	1904-A	COVER PER	
88	1904-A	COVER PER	
89	1904-A	COVER PER	
90	1904-A	COVER PER	
91	1904-A	COVER PER	
92	1904-A	COVER PER	
93	1904-A	COVER PER	
94	1904-A	COVER PER	
95	1904-A	COVER PER	
96	1904-A	COVER PER	
97	1904-A	COVER PER	
98	1904-A	COVER PER	
99	1904-A	COVER PER	
100	1904-A	COVER PER	

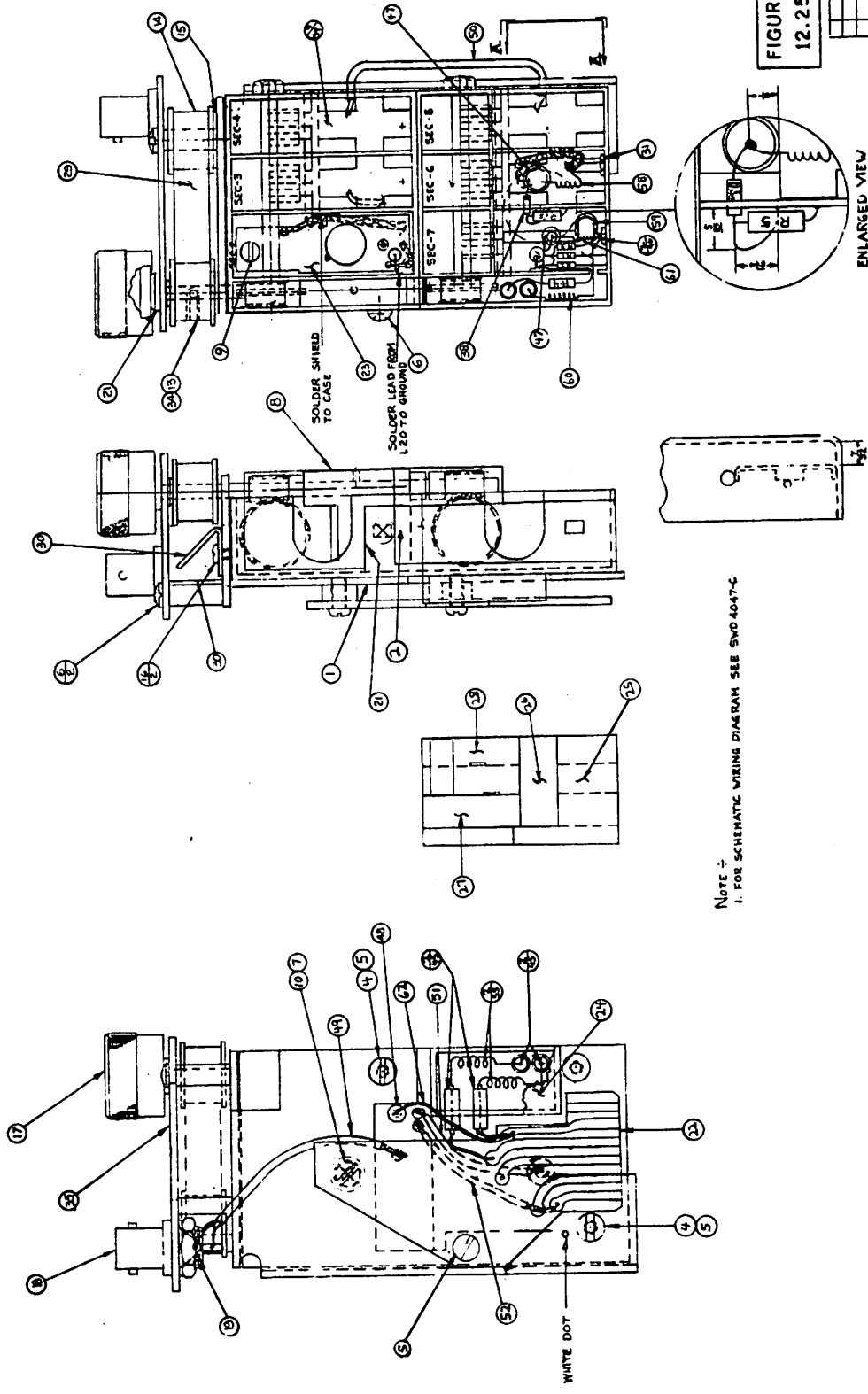

FIGURE 12.25

ENLARGED VIEW

SECTION

NOTE: 1. FOR SCHEMATIC WIRING DIAGRAM SEE SVD 4047-C

REVISED USED ON 10

TUNER ASSY TAG-8

30150-D 16

13-51 347 42 63 4

WIRING PART NO	PART NAME
1	CASE L.F.R.
2	WIRING ASSY
3	1800VA KNOB CONTROL
4	1800VA KNOB PULL
5	3005A SHAFT
6	440-10-104 SCREW #2-10 TAPP HD. TRUCK
7	440-10-104 SCREW #2-10 TAPP HD. TRUCK
8	1086-0 TUNER ASSY. TA3-03
9	440-10-104 SCREW #2-10 TAPP HD. TRUCK
10	1086-0 TUNER ASSY. TA3-03
11	1086-0 TUNER ASSY. TA3-03
12	440-10-104 SCREW #2-10 TAPP HD. TRUCK
13	1086-0 TUNER ASSY. TA3-03
14	440-10-104 SCREW #2-10 TAPP HD. TRUCK
15	1086-0 TUNER ASSY. TA3-03

USED ONLY FOR SER. NO. 1 TO 101

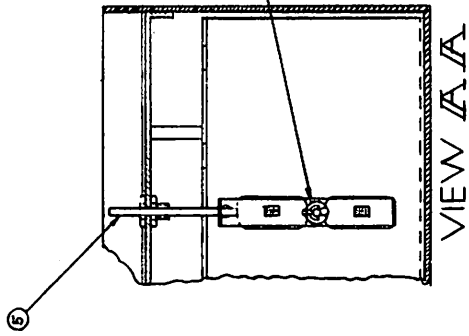
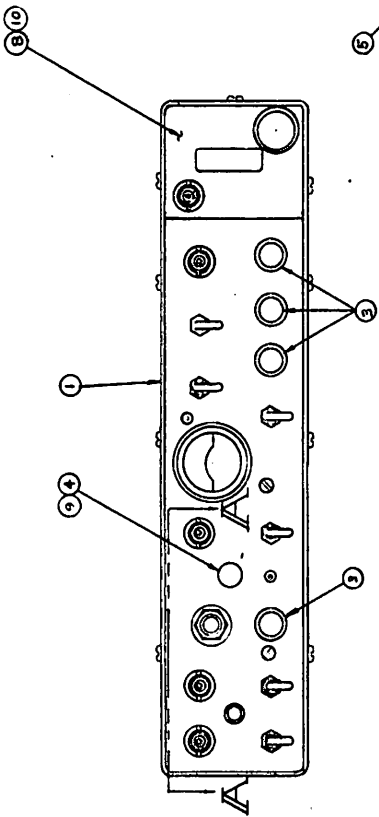

REMOVE REMAINING RING & ADD SHIRT TO SWITCH ARM ASSEMBLY & REPLACE REMAINING RING AT ASSY

FIGURE 12.26

MANUFACTURED BY	HARRIS ENGINEERING INC
MODEL NO.	1700 PWR AS
DATE	4-14-66
REV.	30200-D

13-106-3

REV	DATE	BY	CHKD	DESCRIPTION
1	12-18-57	J. J. [unclear]	[unclear]	ISSUED FOR FABRICATION
2	12-18-57	[unclear]	[unclear]	REVISION
3	12-18-57	[unclear]	[unclear]	REVISION
4	12-18-57	[unclear]	[unclear]	REVISION
5	12-18-57	[unclear]	[unclear]	REVISION
6	12-18-57	[unclear]	[unclear]	REVISION
7	12-18-57	[unclear]	[unclear]	REVISION
8	12-18-57	[unclear]	[unclear]	REVISION
9	12-18-57	[unclear]	[unclear]	REVISION
10	12-18-57	[unclear]	[unclear]	REVISION

ITEM	DESCRIPTION	QTY	UNIT
1	1/2" DIA. ALUM. CAP. (10000)	1	PCB
2	1/2" DIA. ALUM. CAP. (10000)	1	PCB
3	1/2" DIA. ALUM. CAP. (10000)	1	PCB
4	1/2" DIA. ALUM. CAP. (10000)	1	PCB
5	1/2" DIA. ALUM. CAP. (10000)	1	PCB
6	1/2" DIA. ALUM. CAP. (10000)	1	PCB
7	1/2" DIA. ALUM. CAP. (10000)	1	PCB
8	1/2" DIA. ALUM. CAP. (10000)	1	PCB
9	1/2" DIA. ALUM. CAP. (10000)	1	PCB
10	1/2" DIA. ALUM. CAP. (10000)	1	PCB
11	1/2" DIA. ALUM. CAP. (10000)	1	PCB
12	1/2" DIA. ALUM. CAP. (10000)	1	PCB
13	1/2" DIA. ALUM. CAP. (10000)	1	PCB
14	1/2" DIA. ALUM. CAP. (10000)	1	PCB
15	1/2" DIA. ALUM. CAP. (10000)	1	PCB
16	1/2" DIA. ALUM. CAP. (10000)	1	PCB
17	1/2" DIA. ALUM. CAP. (10000)	1	PCB
18	1/2" DIA. ALUM. CAP. (10000)	1	PCB
19	1/2" DIA. ALUM. CAP. (10000)	1	PCB
20	1/2" DIA. ALUM. CAP. (10000)	1	PCB
21	1/2" DIA. ALUM. CAP. (10000)	1	PCB
22	1/2" DIA. ALUM. CAP. (10000)	1	PCB
23	1/2" DIA. ALUM. CAP. (10000)	1	PCB
24	1/2" DIA. ALUM. CAP. (10000)	1	PCB
25	1/2" DIA. ALUM. CAP. (10000)	1	PCB
26	1/2" DIA. ALUM. CAP. (10000)	1	PCB
27	1/2" DIA. ALUM. CAP. (10000)	1	PCB
28	1/2" DIA. ALUM. CAP. (10000)	1	PCB
29	1/2" DIA. ALUM. CAP. (10000)	1	PCB
30	1/2" DIA. ALUM. CAP. (10000)	1	PCB
31	1/2" DIA. ALUM. CAP. (10000)	1	PCB
32	1/2" DIA. ALUM. CAP. (10000)	1	PCB
33	1/2" DIA. ALUM. CAP. (10000)	1	PCB
34	1/2" DIA. ALUM. CAP. (10000)	1	PCB
35	1/2" DIA. ALUM. CAP. (10000)	1	PCB
36	1/2" DIA. ALUM. CAP. (10000)	1	PCB
37	1/2" DIA. ALUM. CAP. (10000)	1	PCB
38	1/2" DIA. ALUM. CAP. (10000)	1	PCB
39	1/2" DIA. ALUM. CAP. (10000)	1	PCB
40	1/2" DIA. ALUM. CAP. (10000)	1	PCB
41	1/2" DIA. ALUM. CAP. (10000)	1	PCB
42	1/2" DIA. ALUM. CAP. (10000)	1	PCB
43	1/2" DIA. ALUM. CAP. (10000)	1	PCB
44	1/2" DIA. ALUM. CAP. (10000)	1	PCB
45	1/2" DIA. ALUM. CAP. (10000)	1	PCB
46	1/2" DIA. ALUM. CAP. (10000)	1	PCB
47	1/2" DIA. ALUM. CAP. (10000)	1	PCB
48	1/2" DIA. ALUM. CAP. (10000)	1	PCB
49	1/2" DIA. ALUM. CAP. (10000)	1	PCB
50	1/2" DIA. ALUM. CAP. (10000)	1	PCB
51	1/2" DIA. ALUM. CAP. (10000)	1	PCB
52	1/2" DIA. ALUM. CAP. (10000)	1	PCB
53	1/2" DIA. ALUM. CAP. (10000)	1	PCB
54	1/2" DIA. ALUM. CAP. (10000)	1	PCB
55	1/2" DIA. ALUM. CAP. (10000)	1	PCB
56	1/2" DIA. ALUM. CAP. (10000)	1	PCB
57	1/2" DIA. ALUM. CAP. (10000)	1	PCB
58	1/2" DIA. ALUM. CAP. (10000)	1	PCB
59	1/2" DIA. ALUM. CAP. (10000)	1	PCB
60	1/2" DIA. ALUM. CAP. (10000)	1	PCB
61	1/2" DIA. ALUM. CAP. (10000)	1	PCB
62	1/2" DIA. ALUM. CAP. (10000)	1	PCB
63	1/2" DIA. ALUM. CAP. (10000)	1	PCB
64	1/2" DIA. ALUM. CAP. (10000)	1	PCB
65	1/2" DIA. ALUM. CAP. (10000)	1	PCB
66	1/2" DIA. ALUM. CAP. (10000)	1	PCB
67	1/2" DIA. ALUM. CAP. (10000)	1	PCB
68	1/2" DIA. ALUM. CAP. (10000)	1	PCB
69	1/2" DIA. ALUM. CAP. (10000)	1	PCB
70	1/2" DIA. ALUM. CAP. (10000)	1	PCB
71	1/2" DIA. ALUM. CAP. (10000)	1	PCB
72	1/2" DIA. ALUM. CAP. (10000)	1	PCB
73	1/2" DIA. ALUM. CAP. (10000)	1	PCB
74	1/2" DIA. ALUM. CAP. (10000)	1	PCB
75	1/2" DIA. ALUM. CAP. (10000)	1	PCB
76	1/2" DIA. ALUM. CAP. (10000)	1	PCB
77	1/2" DIA. ALUM. CAP. (10000)	1	PCB
78	1/2" DIA. ALUM. CAP. (10000)	1	PCB
79	1/2" DIA. ALUM. CAP. (10000)	1	PCB
80	1/2" DIA. ALUM. CAP. (10000)	1	PCB
81	1/2" DIA. ALUM. CAP. (10000)	1	PCB
82	1/2" DIA. ALUM. CAP. (10000)	1	PCB
83	1/2" DIA. ALUM. CAP. (10000)	1	PCB
84	1/2" DIA. ALUM. CAP. (10000)	1	PCB
85	1/2" DIA. ALUM. CAP. (10000)	1	PCB
86	1/2" DIA. ALUM. CAP. (10000)	1	PCB
87	1/2" DIA. ALUM. CAP. (10000)	1	PCB
88	1/2" DIA. ALUM. CAP. (10000)	1	PCB
89	1/2" DIA. ALUM. CAP. (10000)	1	PCB
90	1/2" DIA. ALUM. CAP. (10000)	1	PCB
91	1/2" DIA. ALUM. CAP. (10000)	1	PCB
92	1/2" DIA. ALUM. CAP. (10000)	1	PCB
93	1/2" DIA. ALUM. CAP. (10000)	1	PCB
94	1/2" DIA. ALUM. CAP. (10000)	1	PCB
95	1/2" DIA. ALUM. CAP. (10000)	1	PCB
96	1/2" DIA. ALUM. CAP. (10000)	1	PCB
97	1/2" DIA. ALUM. CAP. (10000)	1	PCB
98	1/2" DIA. ALUM. CAP. (10000)	1	PCB
99	1/2" DIA. ALUM. CAP. (10000)	1	PCB
100	1/2" DIA. ALUM. CAP. (10000)	1	PCB

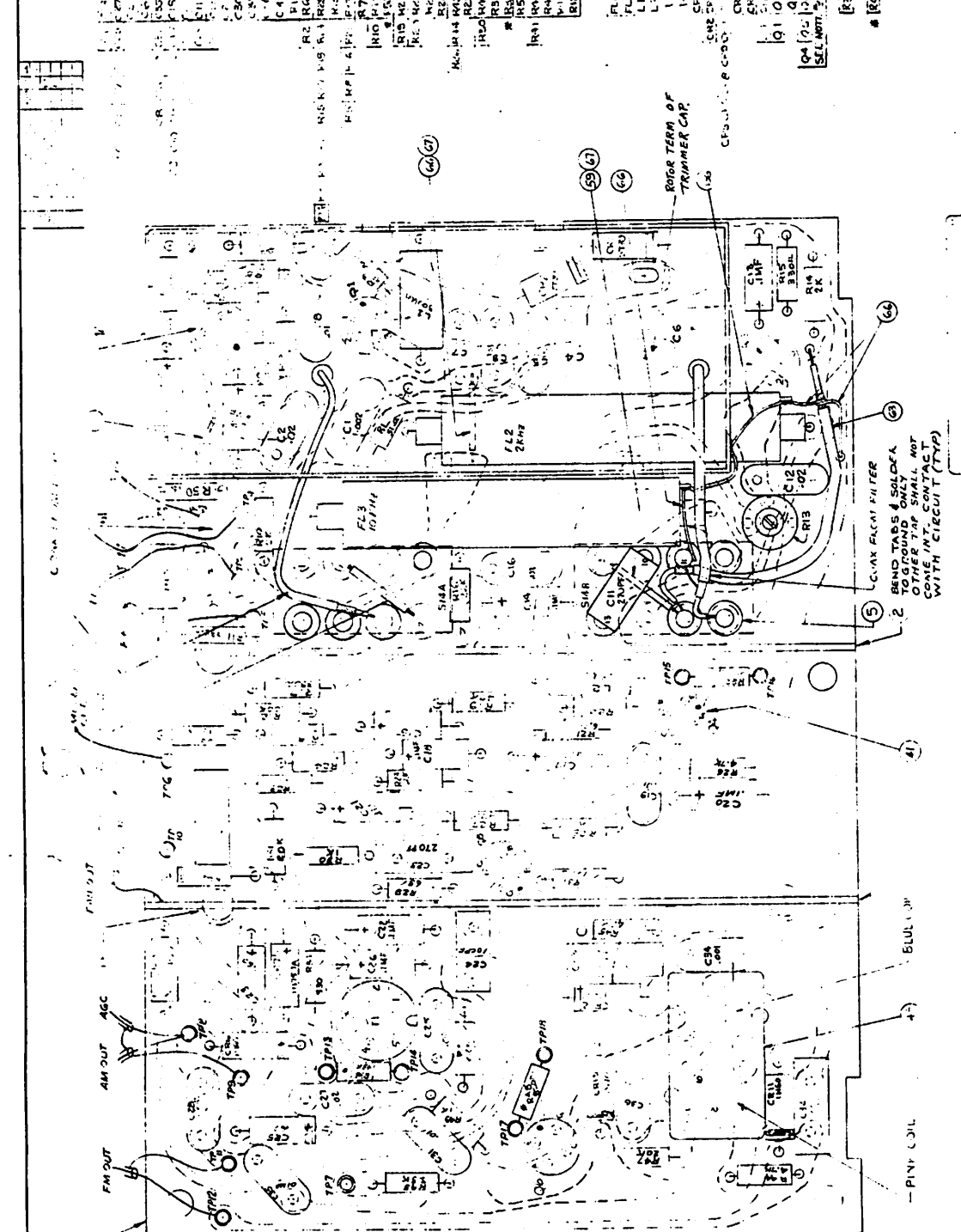

FIGURE 12.27

4 ASSEMBLE COVER WITH HOLE CENTRAL WITH ADJUSTING SCREW ON C-6 (ITEM 9)

3 TURN TABS INWARD & SOLDER

2 SOLDER ALL EYELETS TO CONTACT LANDS

1 PINN COIL

NOTE 1. ALL V. SEALER (ITEM 1) TO BE USED AS REQUIRED.

2. RECOMMENDED DIMENSIONS TOLERANCES: ±0.005 IN.

3. DIMENSIONS IN ANGLES SHALL BE AS SHOWN UNLESS OTHERWISE SPECIFIED.

4. * INDICATES FACTORY SELECTED VALUE

PRINTED CIRCUIT BOARD ASSY. PWD 4031-D

DATE	BY	REVISION	REASON	DATE	BY
		1	SEE E2-33	1/75	AL
		2	SEE E2-33	1/75	AL
		3	SEE E2-33	1/75	AL
		4	SEE E2-33	1/75	AL
		5	SEE E2-33	1/75	AL
		6	SEE E2-33	1/75	AL

CIR. REQ.	PART NO.	DESCRIPTION
1	4032-C	P.C. BOARD (45 MASS.)
2	STD-2	SUMMER WIRE 1/16
TZ	1	TRANSFORMER, AUDIO MNTS.-1B
T3	1	" " " " " " " "
R51	2	1000A-32 RESISTOR 5.5K
R52	2	" " " " " " " "
R53	7	1/2-WATT-32 " " " " " " " "
R54	8	1/2-WATT-32 " " " " " " " "
R55	9	10.000A-32 " " " " " " " "
R56	10	10-WATT-32 " " " " " " " "
R57	11	1/2-WATT-32 " " " " " " " "
R58	12	1/2-WATT-32 " " " " " " " "
R59	13	1/2-WATT-32 " " " " " " " "
R60	14	1/2-WATT-32 " " " " " " " "
R61	15	1/2-WATT-32 " " " " " " " "
R62	16	RESISTOR 100K
R63	17	CAPACITOR 1MF 50V CS35BF 105K
R64	18	" " " " " " " "
R65	19	" " " " " " " "
R66	20	" " " " " " " "
R67	21	" " " " " " " "
R68	22	" " " " " " " "
R69	23	" " " " " " " "
R70	24	" " " " " " " "
R71	25	" " " " " " " "
R72	26	" " " " " " " "
R73	27	" " " " " " " "
R74	28	" " " " " " " "
R75	29	" " " " " " " "
R76	30	" " " " " " " "
R77	31	" " " " " " " "
R78	32	" " " " " " " "
R79	33	" " " " " " " "
R80	34	" " " " " " " "
R81	35	" " " " " " " "
R82	36	" " " " " " " "
R83	37	" " " " " " " "
R84	38	" " " " " " " "
R85	39	" " " " " " " "
R86	40	" " " " " " " "
R87	41	" " " " " " " "
R88	42	" " " " " " " "
R89	43	" " " " " " " "
R90	44	" " " " " " " "
R91	45	" " " " " " " "
R92	46	" " " " " " " "
R93	47	" " " " " " " "
R94	48	" " " " " " " "
R95	49	" " " " " " " "
R96	50	" " " " " " " "
R97	51	" " " " " " " "
R98	52	" " " " " " " "
R99	53	" " " " " " " "
R100	54	" " " " " " " "
R101	55	" " " " " " " "
R102	56	" " " " " " " "
R103	57	" " " " " " " "
R104	58	" " " " " " " "
R105	59	" " " " " " " "
R106	60	" " " " " " " "
R107	61	" " " " " " " "
R108	62	" " " " " " " "
R109	63	" " " " " " " "
R110	64	" " " " " " " "
R111	65	" " " " " " " "
R112	66	" " " " " " " "
R113	67	" " " " " " " "
R114	68	" " " " " " " "
R115	69	" " " " " " " "
R116	70	" " " " " " " "
R117	71	" " " " " " " "
R118	72	" " " " " " " "
R119	73	" " " " " " " "
R120	74	" " " " " " " "
R121	75	" " " " " " " "
R122	76	" " " " " " " "
R123	77	" " " " " " " "
R124	78	" " " " " " " "
R125	79	" " " " " " " "
R126	80	" " " " " " " "
R127	81	" " " " " " " "
R128	82	" " " " " " " "
R129	83	" " " " " " " "
R130	84	" " " " " " " "
R131	85	" " " " " " " "
R132	86	" " " " " " " "
R133	87	" " " " " " " "
R134	88	" " " " " " " "
R135	89	" " " " " " " "
R136	90	" " " " " " " "
R137	91	" " " " " " " "
R138	92	" " " " " " " "
R139	93	" " " " " " " "
R140	94	" " " " " " " "
R141	95	" " " " " " " "
R142	96	" " " " " " " "
R143	97	" " " " " " " "
R144	98	" " " " " " " "
R145	99	" " " " " " " "
R146	100	" " " " " " " "

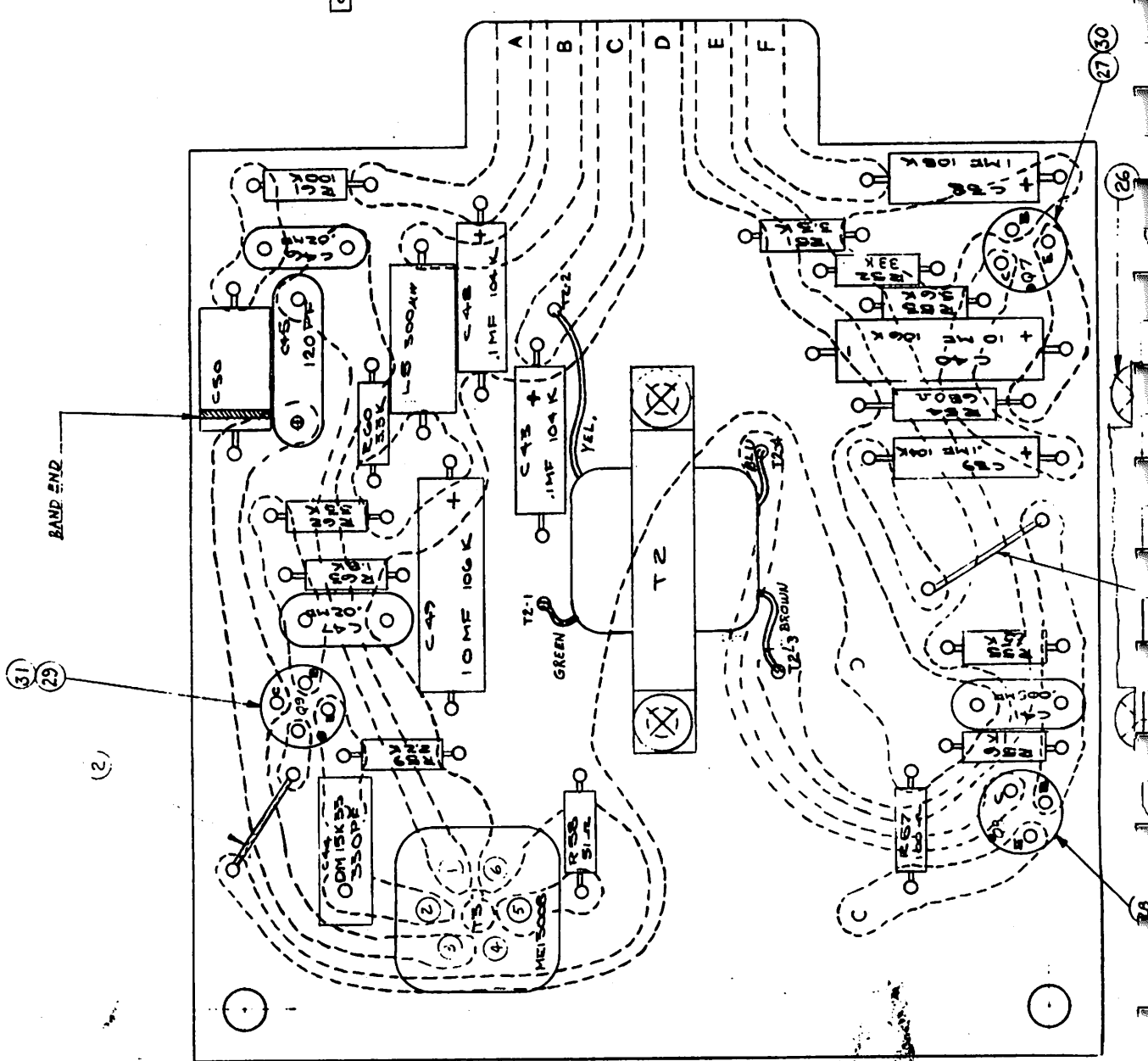

FIGURE 12.2B

MASON ENGINEERING INC.
1700 POST RD. FAIRFIELD, CT 06424

TOLERANCES UNLESS OTHERWISE SPECIFIED:
RESISTORS: 5%
CAPACITORS: 5%
DIMENSIONS: AS SHOWN

DATE: 1-15-75
DRAWN BY: P.S.B.D
CHECKED BY: J.S.
APPROVED BY: J.S.

QUANTITY: 4:11

USER ON 104

REV	DATE	BY	REVISION RECORD	AMPLIFIED	DO	CR
1	SEE ER-552	CA	FB			
2	SEE ER-554	FA	FB			
3	SEE ER-823	FB				
4	SEE ER-906	FB				
5	SEE ER-452	FB				
6	SEE ER-497	FB				

CIR. NO.	PART NO.	PART NAME
1	30216-B	PANEL, COMPL. MTG.
2	5207-A	SWITCH, TOGGLE
3	5208-A	" " MOMENTARY
4	5002-A	CONNECTOR, BNC.
5	5440-A	TERMINAL, INS. CAMBION
6	1806-B	POTENTIOMETER 10K
7	1807-B	" " 100K
8	1804-B	" " 10K SMT
9	1801-E	" " 10K
10	5451-A	SOLDER, LUG
11	5456-A	TERMINAL, SOLDER
12	5633-A	RECEPTACLE, POWER
13	6213-A	METER
14	5438-A	TERMINAL, SOLDER
15	5629-A	JACK TEST
16	5627-A	JACK, PHONE
17	24213-A	TUBING, INSULATING
18	STD-2	WIRE, JUMPER (B.W.)
19	4504-A	DIODE IN 2071
20	11950-A	BUSHING
21	2-02M-0043	CAPACITOR .02 MF.
22		
23	5831-B	GRAPHIC PLATE
24	2-1M-0048	CAPACITOR 1MF 35V
25	10-YPO-3-2	RESISTOR 47 K 1/4W

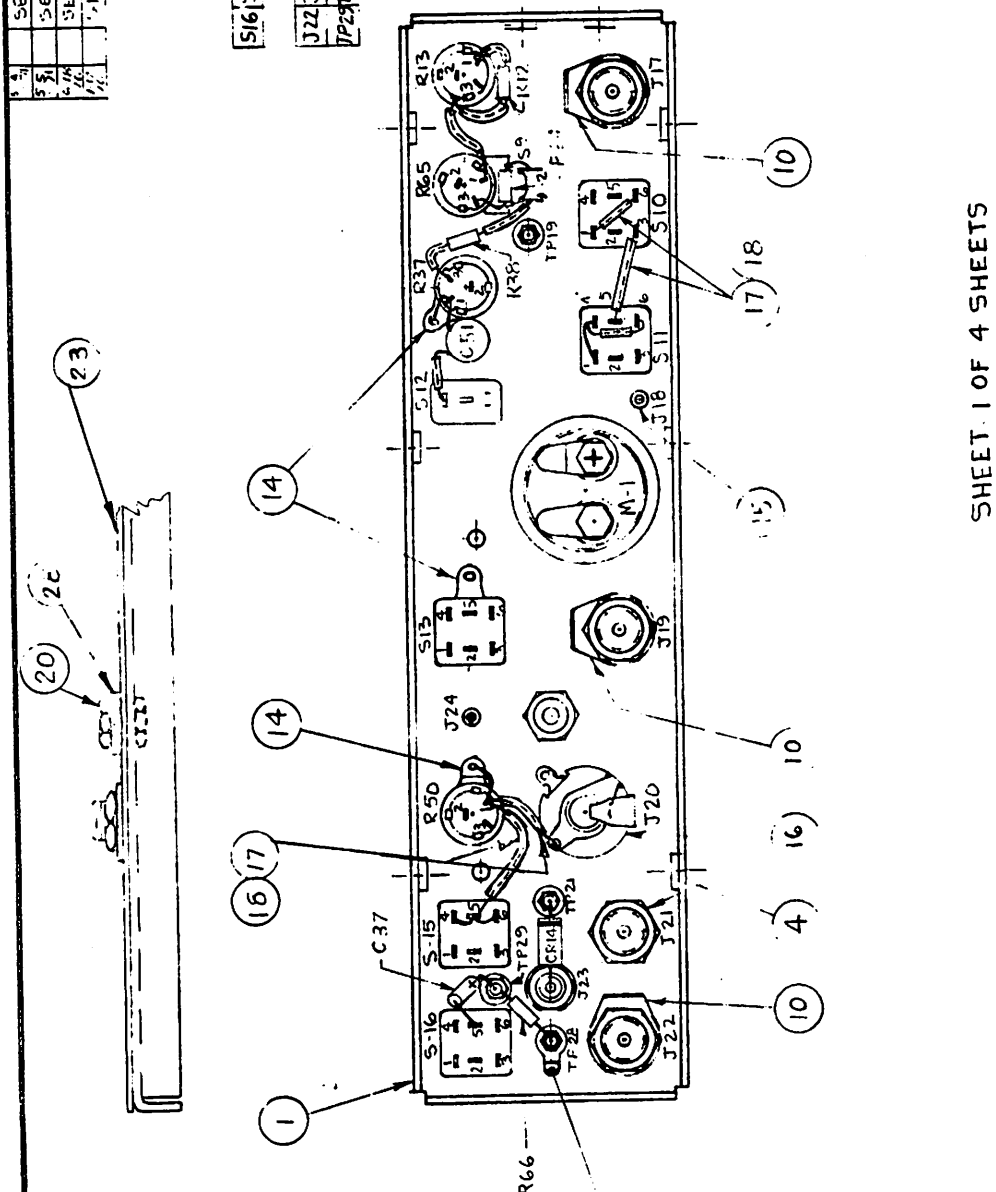

TOLERANCES (EXCEPT AS NOTED)	
DECIMAL	FULL
FRACTIONAL	
ANGULAR	
USED ON	SCALE
1 SHEET NO 2	FULL
DRAWN BY	
APPROVED BY	
MASON ENGINEERING INC.	
1700 POST RD. FAIRFIELD, CONN.	
TITLE	
PANEL ASS'Y, MOUNTING	
DATE	DRAWING NUMBER
	PWD-30215-B
ISSUE	16

SHEET 1 OF 4 SHEETS

FIGURE 12.29A

30			
29	5220-A	SWITCH, TOGGLE (SPDT)	S12
28	17508-A	WASHER, FLAT	
27	10-T80-3-2	RESISTOR 10K 1/4W	R66
26	10-Y1-3-2	RESISTOR 47K 1/4W	R52

DATE	REVISION	RECORD	AUTHN	DR. OR. CZ.
	SEE SHEET 1			

WIRE NO.	WIRE SIZE	PART NO.	PART NAME
31	24-66-4-4-5 1/2		WIRE LEAD (A)
32	24-55-4-4-7 3/4		G
33	24-77-4-4-8 1/2		P
34	24-77-4-4-2 1/2		P
35	24-88-4-4-2 1/2		S
36	24-55-4-4-5 1/2		G
37	24-22-4-4-5 1/4		R
38	24-88-4-4-8 1/4		S
39	24-99-4-4-3 3/4		W
40	24-22-4-4-3 1/4		R
41	24-99-4-4-2 1/4		W
42	24-33-4-4-1 2		O
43	24-22-4-4-2 1/2		R
44	24-33-4-4-3 3/4		WIRE LEAD O
45	7073-A		WIRE COAX
46	24-00-4-4-3 3/8		WIRE LEAD B
47			
48	24-92-4-4-8 1/2		WIRE LEAD W/R
49	24-95-4-4-3 1/2		W/G
50	24-22-4-4-3 3/4		R
51	24-93-4-4-8		W/O
52	24-94-4-4-4 1/4		W/Y
53	24-91-4-4-4 1/2		W/T
54	24-22-4-4-1 1/4		R
55	24-00-4-4-2 1/8		WIRE LEAD B

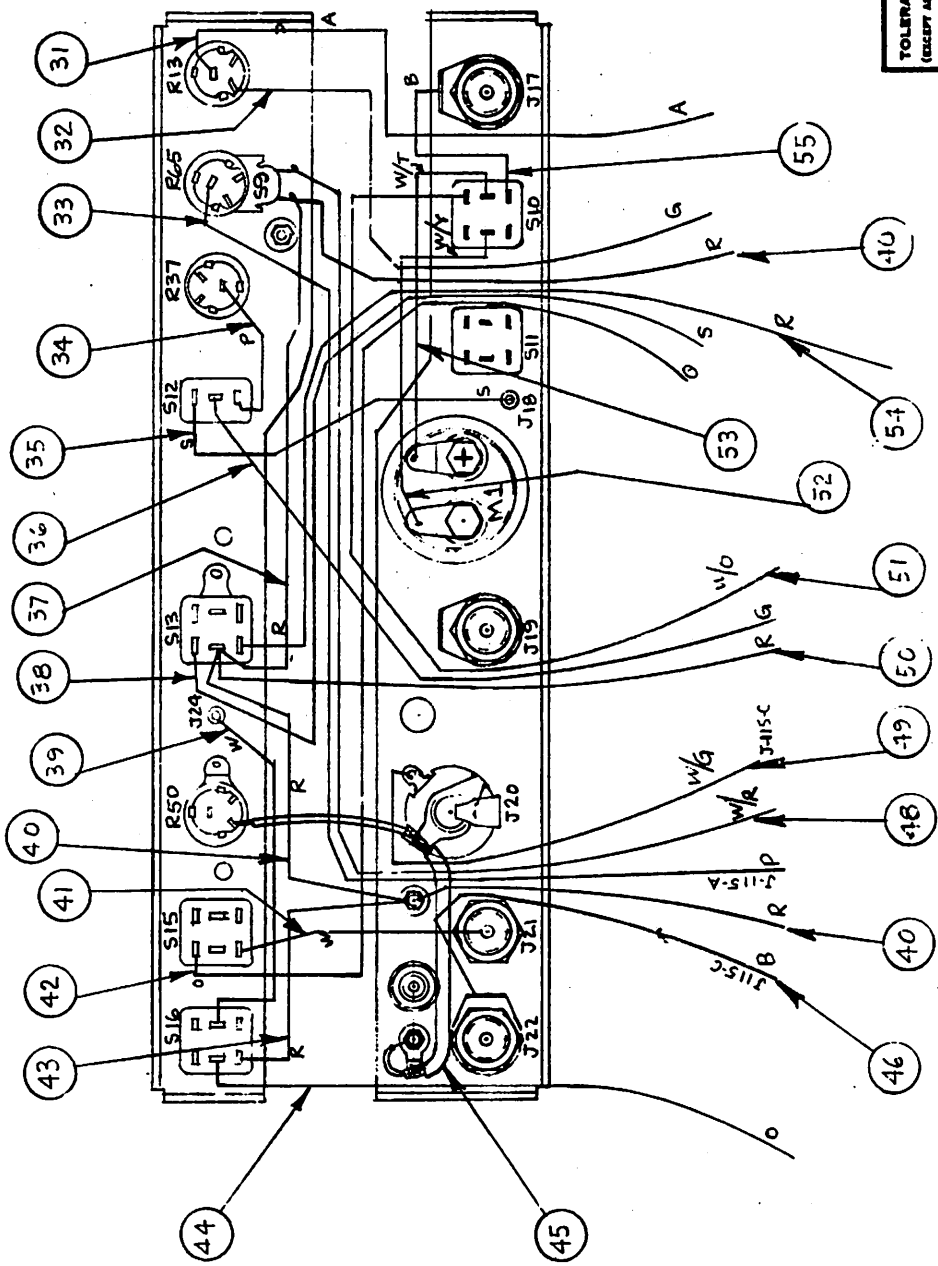

MASON ENGINEERING INC. 1700 POST RD. FAIRFIELD, CONN.		SCALE	DRAWN BY	SPM.
TOLERANCES (EXCEPT AS NOTED)		DECIMAL	APPROVED BY	4/4/53
USED ON		FRACTIONAL	TITLE	
1 SHEET NO 3		ANGULAR	PANEL ASSY. MOUNTING	
FIGURE 12.29-B		DATE		ISSUE
ER-100-J		DRAWING NUMBER		
		8-24-70		PWD-30215-B

SHEET "2" OF "4" SHEETS

DATE	BY	REVISION RECORD	AUTH. DR. CK.
		SEE SHEET 1	

CIRCUIT NO.	PART NO.	PART NAME
60	7062-A	WIRE, COAX.
61	7063-A	WIRE, COAX.
62	7064-A	
63	7025-A	
64	7065-A	
65	7066-A	
66	7067-A	WIRE, COAX.
67	STP-2	WIRE, JUMPER (BW)
68	7068-A	WIRE, COAX.
69	7069-A	
70	7070-A	
71	7071-A	WIRE, COAX.
72	24248-A	TUBING, SHrinkABLE
73	24120-A	WIRE MARKER "A"
74	24124-A	WIRE MARKER "E"
75	24126-A	WIRE MARKER "G"
76	24127-A	WIRE MARKER "H"
77	24128-A	WIRE MARKER "J"
78	24129-A	WIRE MARKER "K"
79	24130-A	WIRE MARKER "L"
80	24131-A	WIRE MARKER "M"
81	24132-A	WIRE MARKER "N"
82	24134-A	WIRE MARKER "Q"

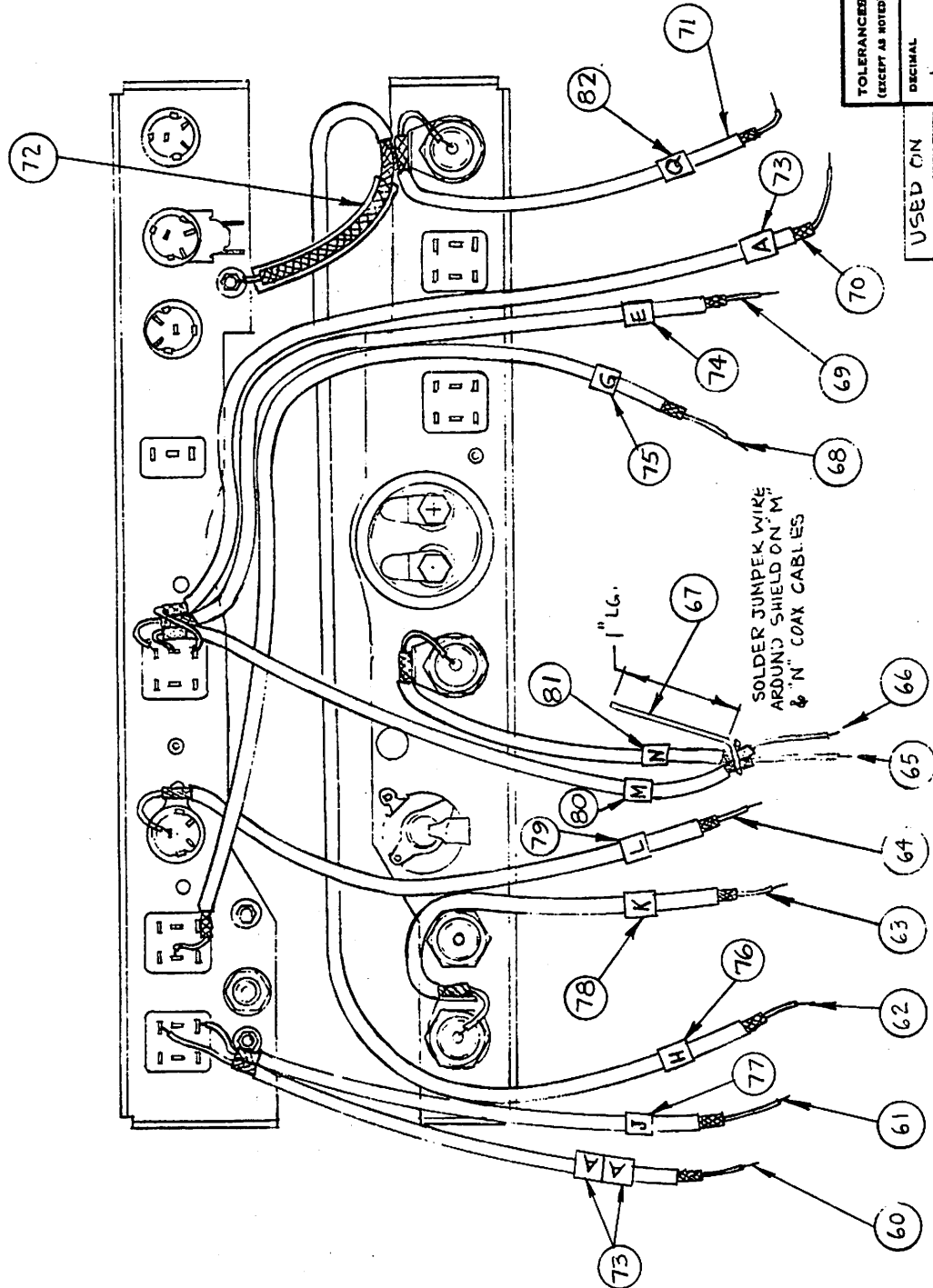

FIGURE
12.29C

TOLERANCES (EXCEPT AS NOTED)	DECIMAL	FRACTIONAL	ANGULAR
	±	±	±
USED ON	1 SHEET NO. 4		
MASON ENGINEERING INC. 1700 POST RD. FAIRFIELD, CONN.			
DRAWN BY SPM		APPROVED BY [Signature]	
TITLE PANEL ASSY. MOUNTING.			
DATE	DRAWING NUMBER	ISSUE	
8-24-70	PWD-30215-B	16	

SHEET "3" OF "4" SHEETS

ER-100-J

DATE	REVISION NUMBER	APPL. CD.	CEL.
	SEE SHEET 1		

CIR. NO.	QTY	PART NO.	PART NAME
90	~	24-247-A	LACING CORD
R36	1	10-T6Y-3-2	RESISTOR 150 K
R39	1	10-T80-3-2	RESISTOR 10K
R40	1	10-00T-3-2	RESISTOR 330-Ω
94	~	24213-A	TUBING INSULATING

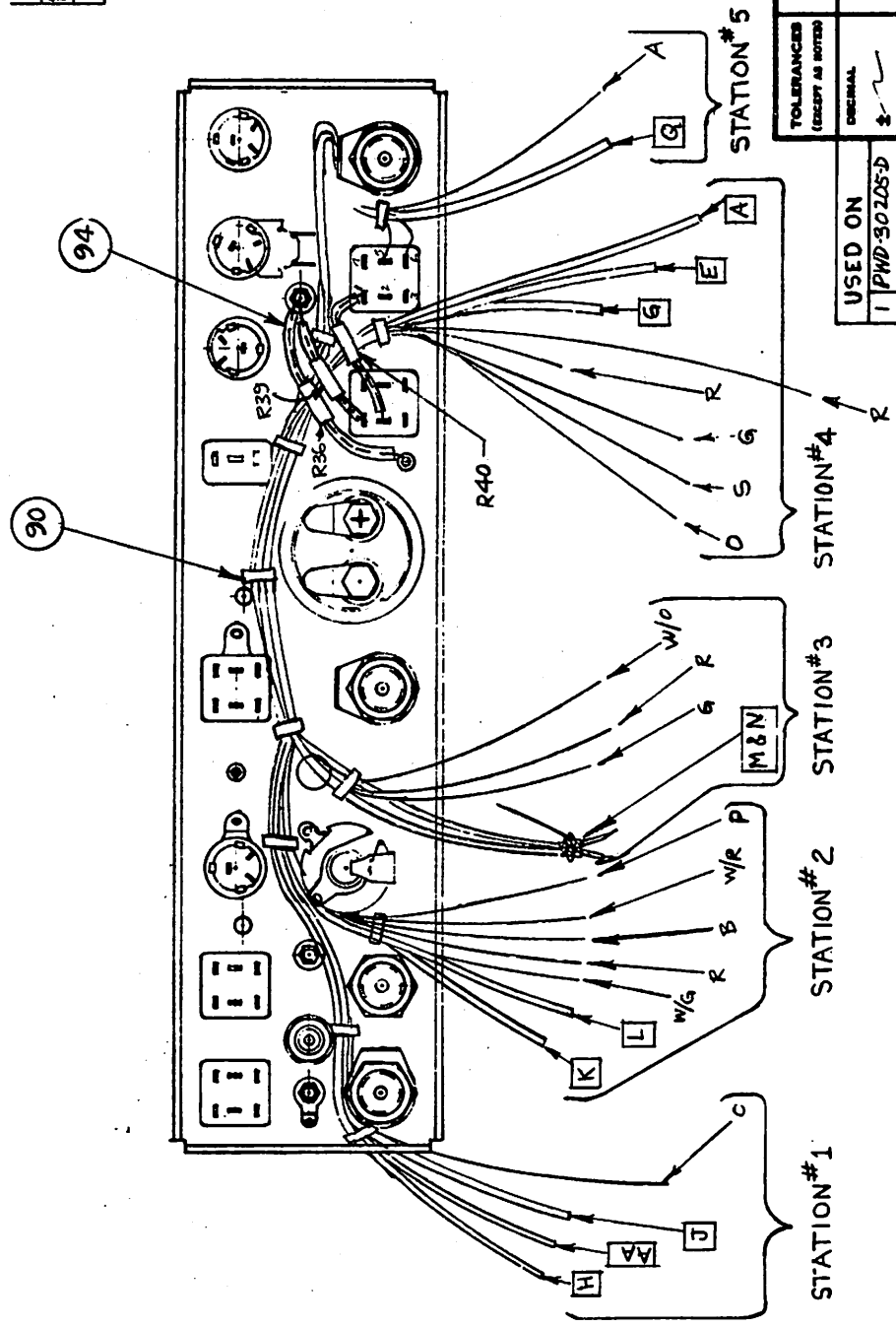

SHEET 4" OF 4" SHEETS

FIGURE 12.29-D

TOLERANCES (EXCEPT AS NOTED)	ORIGINAL	USED ON
DECIMAL	±	1 PWD-30205-D
FRACTIONAL	±	
ANGULAR	±	

MASON ENGINEERING INC. 1700 POST RD. FAIRFIELD, CONN.	SCALE	DESIGNED BY	APPROVED BY
		S.P.H.	P.P.S.
TITLE		DATE	ISSUE
PANEL ASSY MOUNTING		8-24-70	16
DRAWING NUMBER		PWD-30215-B	

DATE	BY	REVISION RECORD	AUTHORITY
1/17/54	WJ	SEE ER-203	CR-1
1/17/54	WJ	SEE ER-259	CR-2
1/17/54	WJ	SEE ER-404	CR-3
1/17/54	WJ	SEE ER-417	CR-4
1/17/54	WJ	SEE ER-482	CR-5
1/17/54	WJ	SEE ER-514	CR-6
1/17/54	WJ	SEE ER-762	CR-7
1/17/54	WJ	SEE ER-795	CR-8

CIR	REL	PART NO.	DESCRIPTION
R3	1	4033-A	PC BD. AS MACH.
R2	2	10-GTB32	RESISTOR 51K
R4	3	10-T6032	" 15K
R9	4	10-TR32	" 4.7K
R11	5	10-RR32	" 2.2K
R5	6	10-RT3-2	" 220Ω
R7	7	10-SMT-52	" 820Ω
R6	8	10-MT3-2	" 350Ω
Q3	9	1-716	TRANSISTOR 2N3646
C4	10	2-0014-003	CAPACITOR .001
C1	11	2-024-0043	" .02 DOM 209
C2	12	2-0114-0040	" .01 DOM 108
C5	13	2-2004-0011	" 200M 25V SPRAG 1/2 300
CR2	14	4516	DIODE 1N765-B
CR3	15	4503	" 1N759A
CR4	16	4512A	" 1N760-A
CR1	17	450B	" PD 717
RB	18	1810	POTENTIOMETER 1KΩ
L1	19	360A	CHOKER, R.F. 307H
R1	20	5427A	SOCKET, TRANSISTOR
	21	1-TR3-2	RESISTOR 1/5K
	22	6	STD-2 JUMPERS 1/2 LG
	23	249-441 1/2	WIRE LEAD (WHITE)
	24	2	STD-2 JUMPER (BW)
	25	1	6221A CABLE TIE
	26	1	5421-A SOLDER LUG #8
	27	24073A	TUBING, INSULATED 1/2 LF
LG	28	3884-A	COIL
C38	29	2-0082	CAPACITOR 120 PF

NOTE :-
* CR-4 MUST HAVE A HIGHER VOLTAGE THAN CR-9 ON PWD-4033-C

FIGURE 12.31

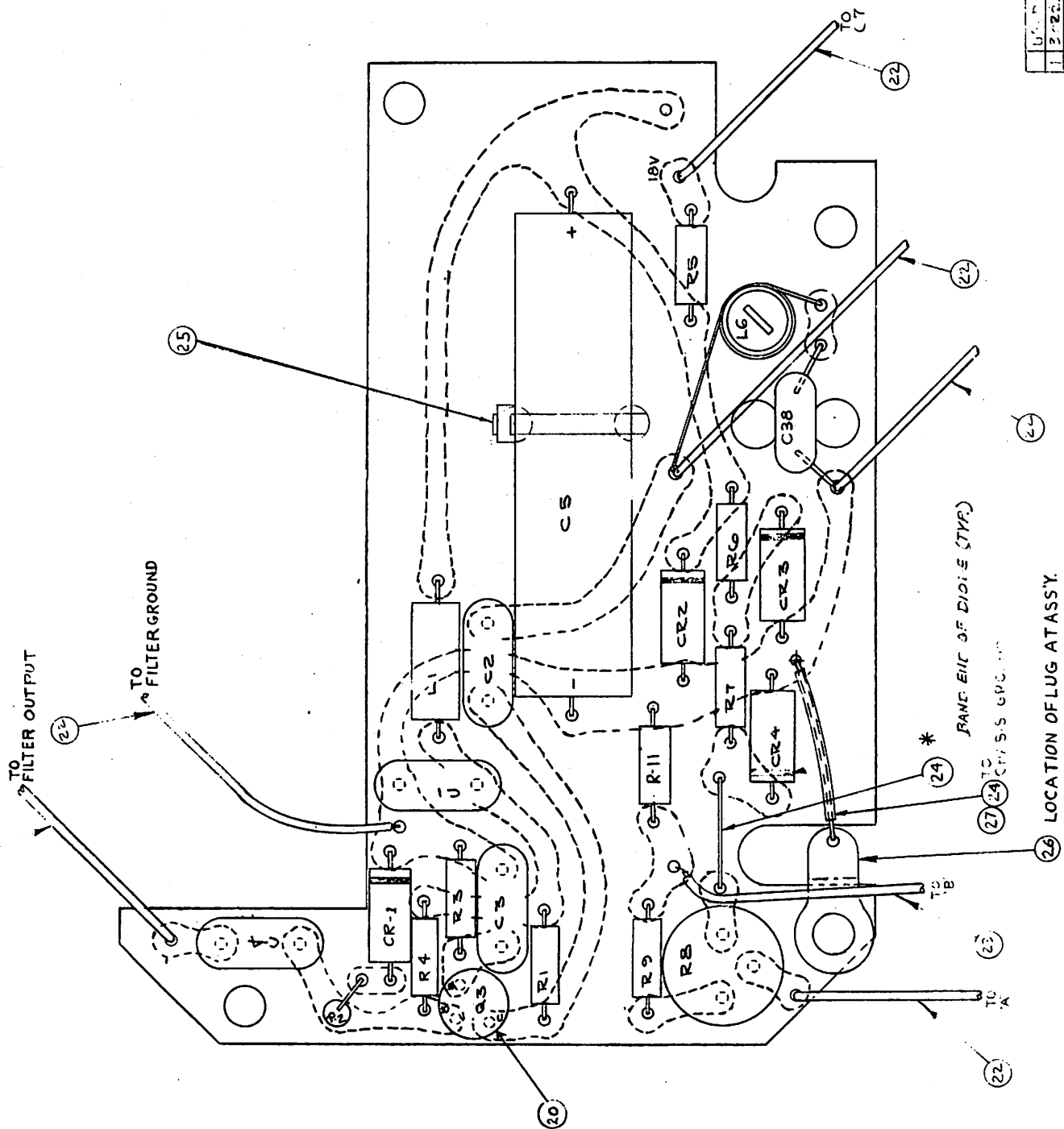

TOLERANCES (EXCEPT AS NOTED)
 ORIGINAL
 FRACTIONAL
 DECIMALS
 ANGLES
 UNLESS SHOWN OTHERWISE
 DATE 1/17/54
 DRAWN BY WJ
 CHECKED BY
 APPROVED BY
 SCALE 4:1
 MASON ENGINEERING INC.
 120 N. 15th St. FAIRFIELD, CONN.
 TITLE PCB BOARD ASSY
 PART NO. C2-1
 DATE 1/17/54
 DRAWN BY WJ
 CHECKED BY
 APPROVED BY
 SCALE 4:1
 MASON ENGINEERING INC.
 120 N. 15th St. FAIRFIELD, CONN.



QTY	PART NO.	PART NAME
1	10-TBT-3-2	RESISTOR 100K 1/4W
2	10-000-3-2	" 33K "
1	10-000-3-2	" 3.3K "
4	10-TBO-3-2	" 10K "
5	10-RRE-3-2	" 2.2K "
1	10-R88-3-2	" 2K "
7	10-TST-7-7	" 180Ω "
1	10-00T-3-2	" 350Ω "
1	10-T84-3-2	" 1MEG "
1	4716	TRANSISTOR 2N3646
1	4725	" 3N199
1	4749	" 40B19
1	2-02-043	CAPACITOR .02MF 50V
1	2-00M-003	" .001MF
1	2-22P-002	" 22PF 50V
2	4546	VARIABLE CAP 500P
1	2-01M-040	" .01MF 50V
2	2-20P-0035	" .002MF 50V
1	2-100P-0020	" 100PF 50V
1	2-200M-0071	" 200MF 50V
1	4516-A	DIODE IN965-B
1	4508	" FD777
1	3-54-A	COIL, SWEPT OSC
1	3-53-A	COIL CONV OUT
1	5927-A	SOCKET TRANSISTOR
1	5925-A	"
1	4034-A	P.C. BOARD (AS MACH)
1	3604-A	CHOKE R.F.
1	STD-2	JUMPER BW 1/2 LG
1	7012-A	WIRE COAX RG196-U-6 1/2
1	6221-A	CABLE TIE
1	24215A	INSULATING TUBING 1/4 LG
1	13083-A	COVER, COIL 1/2 M

FIGURE 12.32

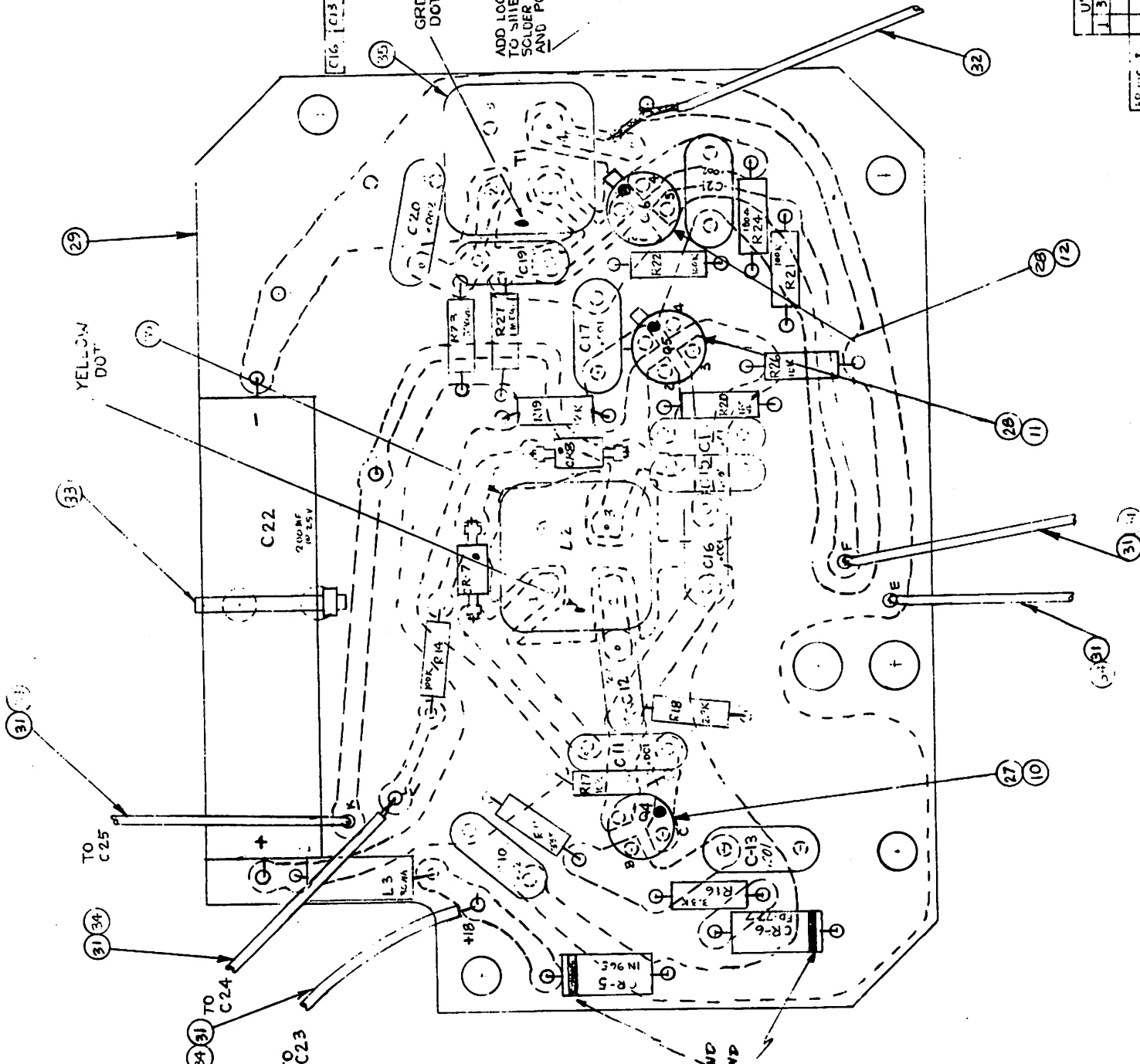

DESIGNED BY	W.F.D. ONI
DRAWN BY	J. S. 02.2.5
CHECKED BY	
APPROVED BY	
DATE	1-7-69
QUANTITY	52-2
DESCRIPTION	PRINTED CIRCUIT BD ASSY
REV	PWD-4034-C
ISSUE	8

YOUR BALANCE IS PAID BY MACH. 1/3/69

RECEIVED BY ALS

DATE 4:1

MASON ENGINEERING INC.
1700 POST RD. FA. FIELD, CONN.

REV	DATE	BY	DESCRIPTION
1			SEE ER-259
2			SEE ER-335
3			SEE ER-417
4			SEE ER-504
5			SEE ER-700

CIR.	REF.	PART NO.	DESCRIPTION
R33	R28	1 4035-A	P.C. BD. AS MACH.
	R29	2 10-TBR-32	RESISTOR 1K
	R30	3 10-NT-32	" 350Ω
	R31	4 10-TBR-32	" 10 MEG.
	R32	5 10-TBR-32	" 2.2 K
	R33	6 10-TBR-32	" 100 K
	C26	7 10-TBR-32	" 120Ω
	C27	8 10-TBR-32	CAPACITOR 100 PF DISC.
	C28	9 10-TBR-32	" .01 DISC.
	C29	10 10-TBR-32	" .02 DISC.
	C30	11 10-TBR-32	" E-60 PF
	C31	12 10-TBR-32	" 10 PF DISC.
	C32	13 10-TBR-32	" .002HP DISC.
	C33	14 10-TBR-32	" .1 MF TANTALUM
	C34	15 10-TBR-32	" 270 PF
	C35	16 10-TBR-32	" 3.3 PF DISC.
	Q7	17 10-TBR-32	TRANSISTOR 40B19
	Q8	18 10-TBR-32	" 3N159
	L4	19 10-TBR-32	CHOKER RE - 1
	L5	20 10-TBR-32	CRACKER RP.
	L6	21 10-TBR-32	TRANSFORMER 1000VA
	VT1	22 10-TBR-32	500V 10A 10.000VDC
	R24	23 10-TBR-32	SEC. TRANSISTOR
	R25	24 10-TBR-32	TERMINAL, TURRET
	R26	25 10-TBR-32	WIRE JUMPER 1 LG
	R27	26 10-TBR-32	RESISTOR 220 K
	R28	27 10-TBR-32	RESISTOR 3.9 MEG.
	R29	28 10-TBR-32	SEALER, P.C. BOARD

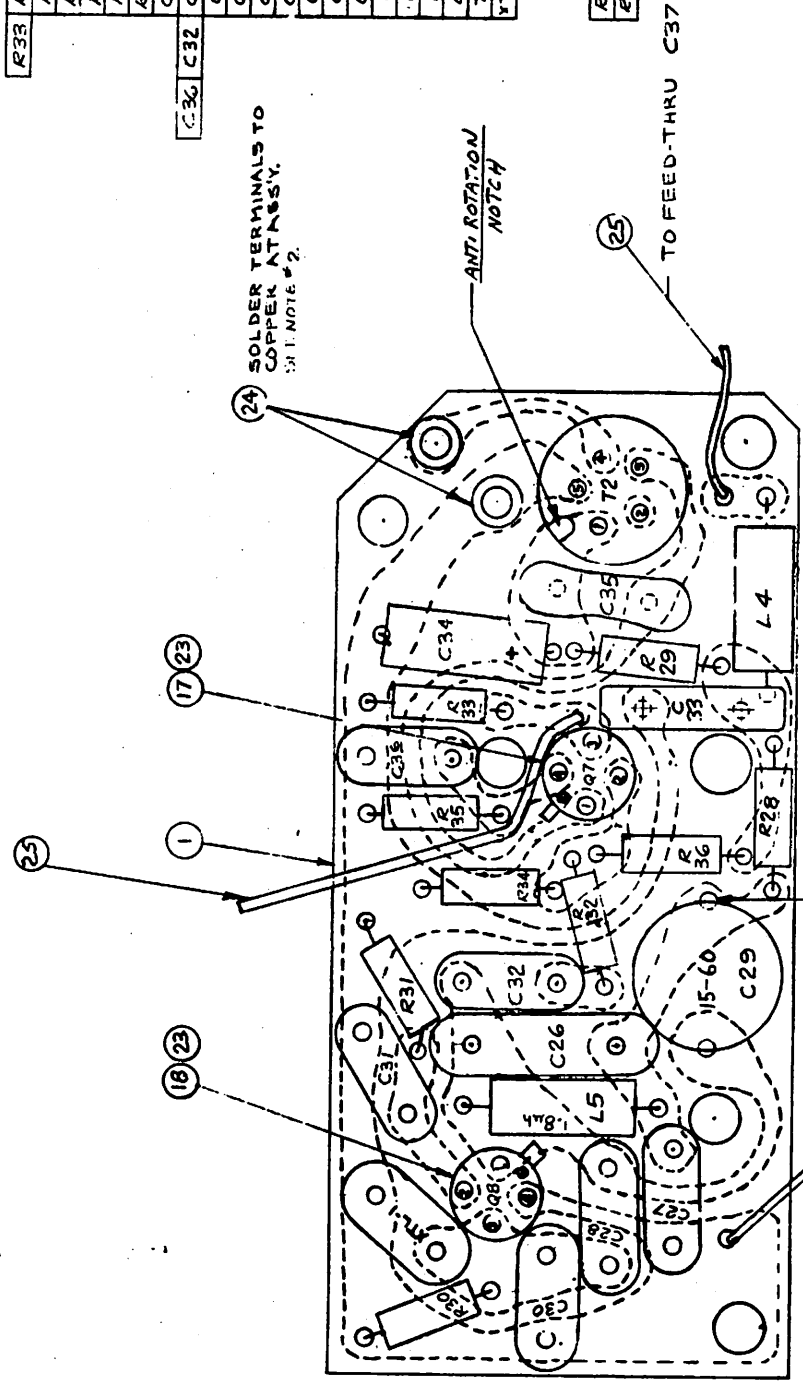

NOTE: -
 1. APPLY SEALER (ITEM #28) TO BOARD AS REQ'D.
 2. RECOMMENDED SWAGING TOOLS FOR ITEM # 24:
 CAMBION ANVIL PSA-6446, CAMBION PUNCH PSP-6603

ROTOR TERM. OF TRIMMER CAP.

TO FILTER GROUND

TO FEED-THRU C37

FIGURE 12.33

MASON ENGINEERING INC.			
1700 POST RD. FAIRFIELD, CT			
TEL: 203-255-1111			
FAX: 203-255-1112			
E-MAIL: SALES@MASON-ENG.COM			
WWW: WWW.MASON-ENG.COM			
DATE: 10/20/88			
DRAWN BY: J. J. J.			
CHECKED BY: J. J. J.			
APPROVED BY: J. J. J.			
SCALE: AS SHOWN			
SHEET NO. 1 OF 1			
PROJECT NO. 1000000000			
CUSTOMER: MASON ENGINEERING INC.			
PART NO. 1000000000			
REV. 1			
REV. 2			
REV. 3			
REV. 4			
REV. 5			
REV. 6			
REV. 7			
REV. 8			
REV. 9			
REV. 10			
REV. 11			
REV. 12			
REV. 13			
REV. 14			
REV. 15			
REV. 16			
REV. 17			
REV. 18			
REV. 19			
REV. 20			
REV. 21			
REV. 22			
REV. 23			
REV. 24			
REV. 25			
REV. 26			
REV. 27			
REV. 28			
REV. 29			
REV. 30			
REV. 31			
REV. 32			
REV. 33			
REV. 34			
REV. 35			
REV. 36			
REV. 37			
REV. 38			
REV. 39			
REV. 40			
REV. 41			
REV. 42			
REV. 43			
REV. 44			
REV. 45			
REV. 46			
REV. 47			
REV. 48			
REV. 49			
REV. 50			
REV. 51			
REV. 52			
REV. 53			
REV. 54			
REV. 55			
REV. 56			
REV. 57			
REV. 58			
REV. 59			
REV. 60			
REV. 61			
REV. 62			
REV. 63			
REV. 64			
REV. 65			
REV. 66			
REV. 67			
REV. 68			
REV. 69			
REV. 70			
REV. 71			
REV. 72			
REV. 73			
REV. 74			
REV. 75			
REV. 76			
REV. 77			
REV. 78			
REV. 79			
REV. 80			
REV. 81			
REV. 82			
REV. 83			
REV. 84			
REV. 85			
REV. 86			
REV. 87			
REV. 88			
REV. 89			
REV. 90			
REV. 91			
REV. 92			
REV. 93			
REV. 94			
REV. 95			
REV. 96			
REV. 97			
REV. 98			
REV. 99			
REV. 100			



DATE	REV	BY	APP
	1	SEE EX 123	

CIR NO	PART NO	PART NAME
1	30151-B	BRACKET COMPL. T33-03-B
2	30152-A	BRACKET WINDOW COMPL. T33-03-B
3	1819-A	POTENTIOMETER, 10 TURN
4	15983-A	SHAFT EXTENDER
5	1403555	SCREW, SET # 4-40 x 3/2
6	6221-A	CABLE TIE
7	5057-A	FILTER, L.P. 300 KC
8	14001-A	5 POOL DRIVE
9	1440-4274	SCREW, SET # 4-40 x 1/8
10	14000-A	SPRING, IDLER
11	15008-A	TAPE DIAL
12	240358	MIRROR
13	2563-5-8	SCREW, # 2-56 x 3/8 PM RD.
14	1740-1-2	P.C. BOARD ASST. T33-03-B
15	15046-A	STANDOFF, MALE/FEMALE
16	12418-B	COVER, HAND (T33-03-B)
17	140-6-65	SCREW, # 2-40 x 7/16 PM RD.
18	17523-A	WASHER # 8 INTERNAL TOOTH
19	5465A	CONNECTOR, BNC.
20	804-A	KNOB
21	10200-A	BUSHING
22	5454-A	SOLDER LUG
23	30151-A	PLATE, WINDOW COMPL. T33-03-B
24	440-84-448	SCREW # 4-40 x 1/2 PAN HD. (BLACK)
25	17551-A	WASHER, FLAT
26	24-33-4-2	WIRE, LEAD (GRANDED)
27	10-22-4-4-2	WIRE, LEAD (RED)
28	14-11-4-4-2	WIRE, LEAD (TAN)
29	17522-A	WASHER, INTERNAL LOCK
30	10001-A	NUT, HEX.

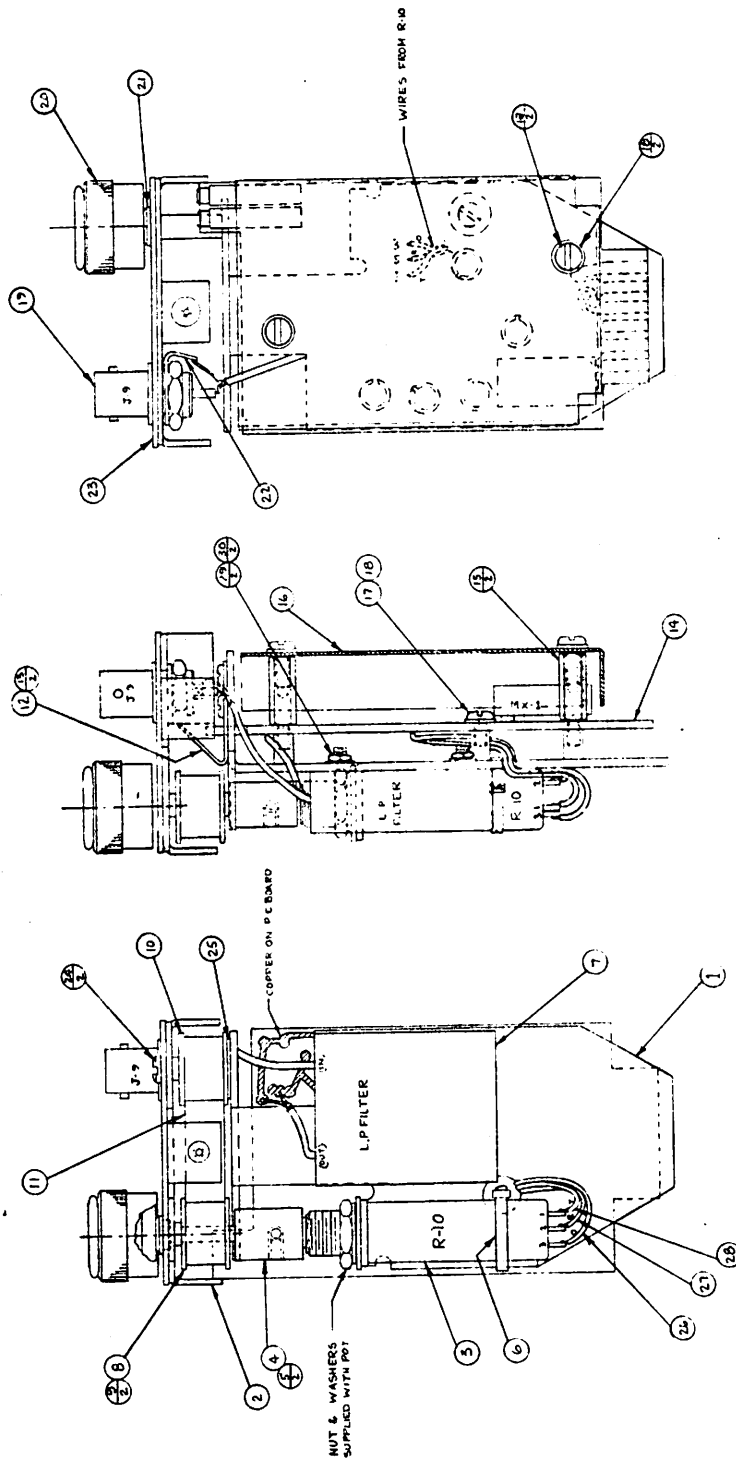

FIGURE 12.34

USED ON	THE FOLLOWING	MASON ENGINEERING INC.
	MODEL NO.	1700 PORT RD., FAIRFIELD, CONN.
	DATE	1964
	BY	S.P.M.
	CHECKED	E.H.
	APPROVED	802
	ISSUE	TUNER ASSY T33-03-B
	REV	2-3-71
	FIGURE NO.	30250-D
	ISSUE NO.	2

EX. 100 W

CIR NO	PART NO	PART NAME
1	473 C	PL BOARD TAB-33B
2	5425-A	SOCKET TRANSISTOR
3	5036-B	MIXER, DOUBLY BALANCED
4	1B03-B	POTENTIOMETER TRIM 10K
5	1B08-B	POTENTIOMETER TRIM 1K
6	10-6TB-3-2	RESISTOR 51A 1/4W 52
7	10-7P0-3-2	RESISTOR 47K
8	10-R60-3-2	RESISTOR 20K
9	10-T80-3-2	RESISTOR 10K
10	10-TBT-3-2	RESISTOR 100A
11	10-TBR-3-2	RESISTOR 1K
12	10-TBY-3-2	RESISTOR 100K
13	10-RRR-3-2	RESISTOR 2.2K
14	10-YPR-3-2	RESISTOR 9.7K
15	10-T50-3-2	RESISTOR 18K
16	10-TST-3-2	RESISTOR 180A
17	10-GTT-3-2	RESISTOR 510A 1/4W 52
18	10-SAT-3-2	RESISTOR 820Ω 1/4W 52
19	10-DOR-3-2	RESISTOR 3.3K 1/4W 52
20	37D-2	JUMPER WIRE BW
21	2-56H-000	CAPACITOR 56pF
22	2-25M-011	CAPACITOR 25μF @ 25V
23	2-10M-006	CAPACITOR 10μF
24	2-01M-0040	CAPACITOR .01μF (DISC)
25	2-100P-0020	CAPACITOR .05μF (DISC)
26	2-05M-0118	CAPACITOR .05μF (DISC)
27	2-1000P-0083	CAPACITOR .001μF (DISC)
28		
29		
30	4508-A	DIODE IN1201
31	4503-A	DIODE IN157A (GX ONLY)
32	4542-A	DIODE BA163
33		
34		
35	3-42D-A	CHOKER 10MH
36	3-277-A	CHOKER 1.5MH
37	3-221-A	CHOKER 22MB
38	4748-A	TRANSISTOR 40894
39	4725-A	TRANSISTOR 3N139
40		
41		
42		
43		
44		
45		
46		
47		
48		
49		
50		
51		
52		
53		
54		
55		
56		
57		
58		
59		
60		
61		
62		
63		
64		
65		
66		
67		
68		
69		
70		
71		
72		
73		
74		
75		
76		
77		
78		
79		
80		
81		
82		
83		
84		
85		
86		
87		
88		
89		
90		
91		
92		
93		
94		
95		
96		
97		
98		
99		
100		

DESIGNED BY	DATE	ISSUED
11/11	11/11	6
MASON ENGINEERING INC. 1700 POST RD, FAIRFIELD, CONN.		
TOLERANCES UNLESS SHOWN LOCATED BY CENTER	SCALE	APPROVED BY
± 1/4	4:1	SPM
TITLE: PCB BOARD ASSY		
PART NO: 1A5-558		
REV: PWD-4071		

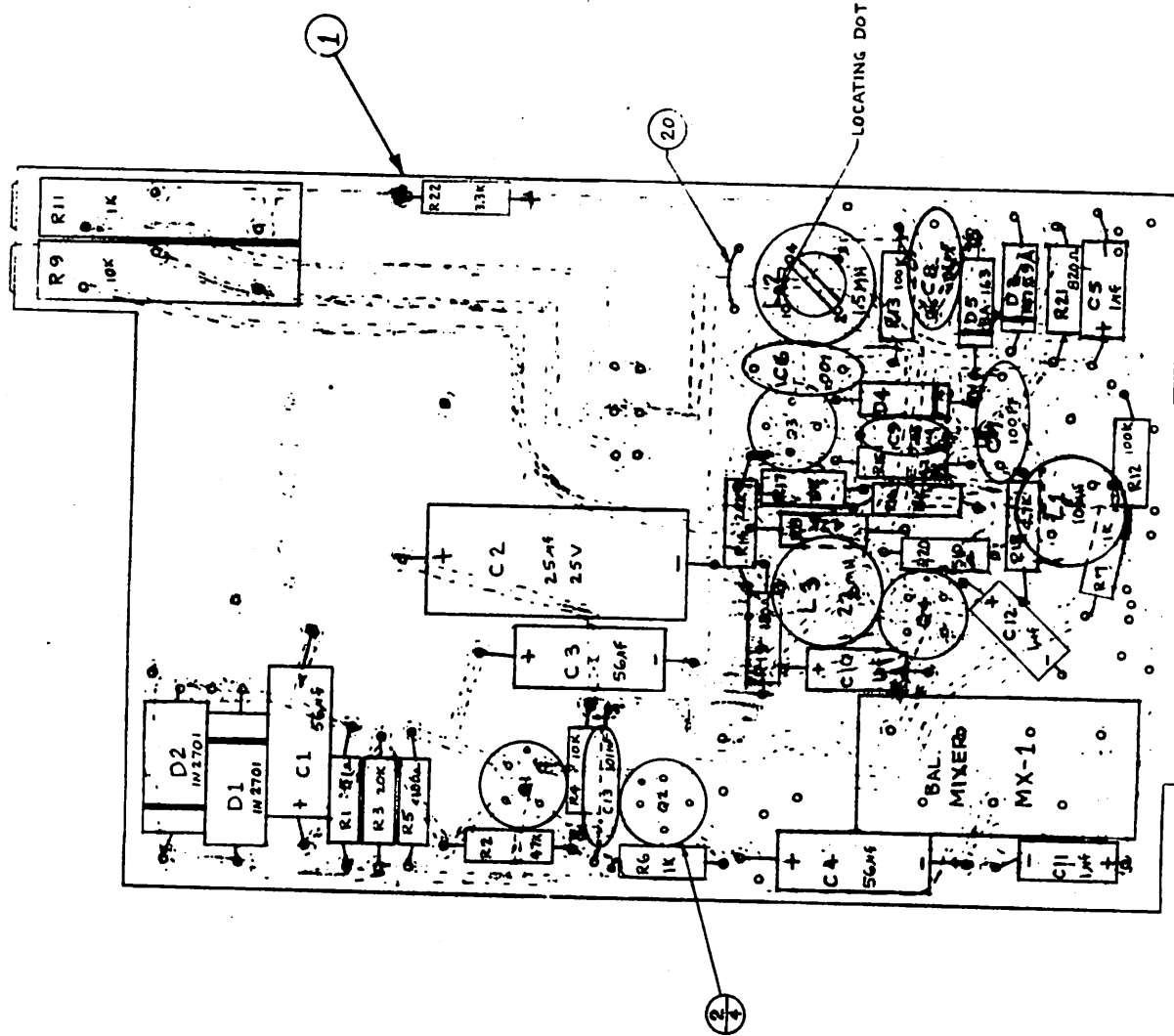

FIGURE 12.35

(A) (B) (C) (D) (E) (F)

ER 100 W

1	30300-C	MONITOR ASSY	1
2	19027-C	CASE	1
3	1751-A	WASHER	1
4	1751-A	WASHER	1
5	1751-A	WASHER	1
6	1751-A	WASHER	1
7	1751-A	WASHER	1
8	1751-A	WASHER	1
9	1751-A	WASHER	1
10	1751-A	WASHER	1
11	1751-A	WASHER	1
12	1751-A	WASHER	1
13	1751-A	WASHER	1
14	1751-A	WASHER	1
15	1751-A	WASHER	1
16	1751-A	WASHER	1

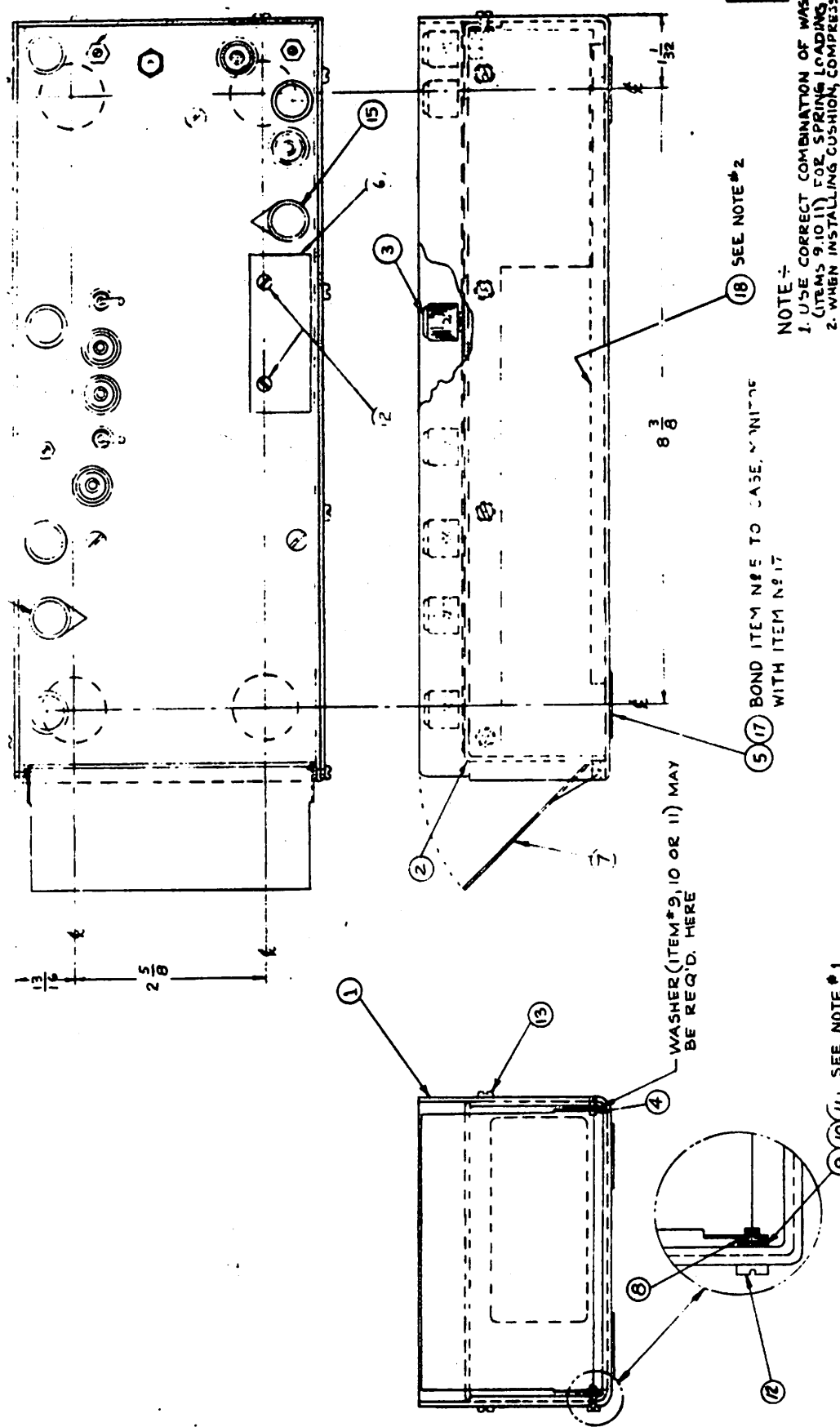

FIGURE 12.36

NOTE -
 1. USE CORRECT COMBINATION OF WASHERS, (ITEMS 9, 10, 11) FOR SPRING LOADINGS.
 2. WHEN INSTALLING CUSHION COMPRESS BAR, AND PUNCTURE EACH CORNER ON TOP SIDE OF BAR.

(18) SEE NOTE # 2

(5) (17) BOND ITEM # 5 TO CASE, WITH ITEM # 17 WITH ITEM # 17

WASHER (ITEM # 9, 10 OR 11) MAY BE REQ'D. HERE

(9) (10) (11) SEE NOTE # 1.

QTY	PART NO.	PART NAME	PART NO.	PART NAME	
1	19027-C	CASE	1	30300-A	CUSHION CR TUB COMP L
2	1751-A	WASHER	19		
3	1751-A	WASHER	20		
4	1751-A	WASHER	21		
5	1751-A	WASHER	22		
6	1751-A	WASHER	23		
7	1751-A	WASHER	24		
8	1751-A	WASHER	25		
9	1751-A	WASHER	26		
10	1751-A	WASHER	27		
11	1751-A	WASHER	28		
12	1751-A	WASHER	29		
13	1751-A	WASHER	30		
14	1751-A	WASHER	31		
15	1751-A	WASHER	32		
16	1751-A	WASHER	33		
17	1751-A	WASHER	34		
18	1751-A	WASHER	35		

USED ON	
1	MRD-30000
2	
3	
4	
5	
6	
7	
8	
9	
10	
11	
12	
13	
14	
15	
16	
17	
18	
19	
20	
21	
22	
23	
24	
25	
26	
27	
28	
29	
30	
31	
32	
33	
34	
35	

30300-C

1ER-006-P

ITEM	PART NO.	DESCRIPTION	QTY
1	4038-C	PC BOARD (AS MACH)	1
2	21076-C	BRACKET VERT AMP	1
3	4055	PC BOARD POT MTG	4
4	17514-A	WASHER FLAT	3
5	5444-A	LUG SOLID BR	3
6	10-TST-32	RESISTOR 180J 1/4W 5%	1
7	10-RRT-32	" 220J "	2
8	10-000-32	" 33K "	1
9	10-GTT-32	" 330J "	2
10	10-TSR-32	" 510J "	1
11	10-00R-32	" 1.8K "	2
12	10-00R-32	" 3.3K "	2
13	10-YPR-32	" 4.7K "	3
14	10-TBO-32	" 10K "	7
15	10-RBO-32	RESISTOR 20K 1/4W 5%	2
16	10-000-32	" 33K "	1
17	10-YPO-32	" 47K "	3
18	10-TRY-32	" 220K "	1
19	10-RRY-32	" 220K "	2
20	10-00Y-32	" 330K "	1
21	10-TBG-32	" 1M "	2
22	10-TGG-32	" 1.5M "	2
23	10-RRG-32	" 2.2M "	1
24	10-TBY-32	" 100K "	3
25	1811	RESISTOR VAR 20K LIN	1
26	1801B	" " 10K LIN	1
27	1802B	" " 100K LIN	2
28	5213	SWITCH 12 POS JENNINGS	1
29	1806B	RESISTOR VAR 10K LOG DB	1
30	7054-A	WIRE COAX	1
31	7056-A	WIRE COAX	1
32	7055-A	WIRE COAX	1
33	4521	DIODE IN914	2
34	4504	DIODE IN2071	1
35	4503	DIODE ZENER IN759A	2
36	4729	TRANSISTOR 2N3643	2
37	4709	" 2N3645	1
38	4730	" 2N3694	3
39	4748-A	" 40894	5
40	5452-A	SOLDER LUG	1
41	2-100P-0077	CAPACITOR 1000mf 100V	1
42	2-0047M-0160	" 4700mf 20V	1
43	2-022M-0075	" .022mf 35V	1
44	2-12M-0159	" .12mf 20V	1
45	2-57M-0158	" .67mf 20V	1
46	2-33M-0112	" 3.3mf 35V	1
47	2-02M-0043	CAPACITOR .02mf 150V	1
48	2-1M-0048	" 1mf 35V	4
49	2-10M-0051	" 10mf 20V	5
50	2-12M-0081	" 47mf 20V	4
51	2-330P-0084	" 330PF	2

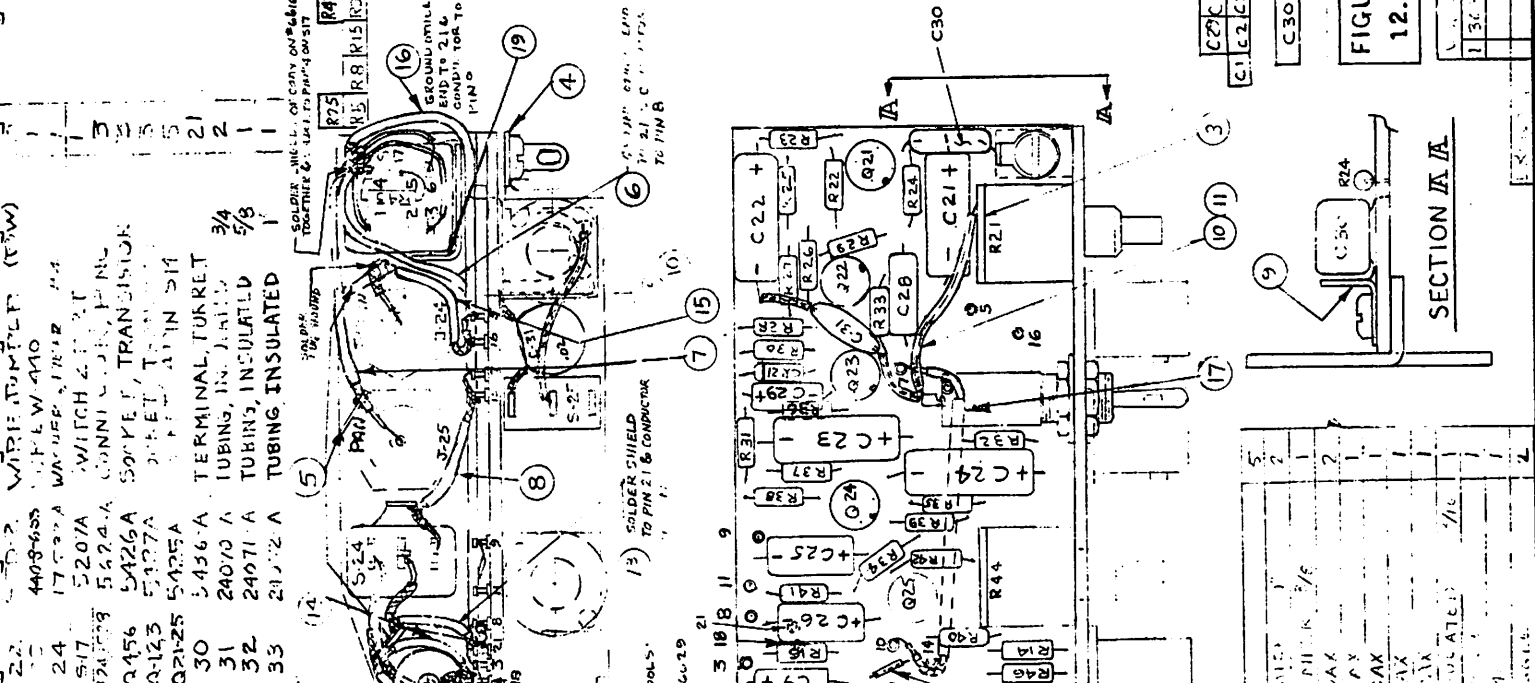

DECIMALS	FRACTIONS	ANGLES	SURFACE ROUGHNESS	DIMENSIONS ARE IN INCHES	ALL DIMS ON SAME ANGLE WITHIN JOB TOLERANCE	BREAK SHARP EDGES 1/8" OR 3/16" MAX	ALL DIMENSIONS AND TOL. APPLY BEFORE FINISH
+	+	+	✓	✓	✓	✓	✓

NOTE: AFTER PRE-ASSY TEST, ADD COATING OF BEYOND CLEAR TO BOTH SIDES OF PC BOARD AT ALL POINTS FROM FRONT OF BOARD (N.C.)

34 5434-A SOLID BR TO PIN 2

ALL TERMINALS MOUNTED THIS SIDE OF BOARD

30 RECOMMENDED SWAGING TOOLS: 1. ANVIL P.S.A. 4-2-2 2. CAMBION PUNCH 4-2-9

31 SOLDER SHIELD TO PIN 21 & COMPACTOR

32 SOLDER SHIELD TO PIN 21 & COMPACTOR

33 SOLDER SHIELD TO PIN 21 & COMPACTOR

34 SOLDER SHIELD TO PIN 21 & COMPACTOR

35 SOLDER SHIELD TO PIN 21 & COMPACTOR

36 SOLDER SHIELD TO PIN 21 & COMPACTOR

37 SOLDER SHIELD TO PIN 21 & COMPACTOR

38 SOLDER SHIELD TO PIN 21 & COMPACTOR

39 SOLDER SHIELD TO PIN 21 & COMPACTOR

40 SOLDER SHIELD TO PIN 21 & COMPACTOR

41 SOLDER SHIELD TO PIN 21 & COMPACTOR

42 SOLDER SHIELD TO PIN 21 & COMPACTOR

43 SOLDER SHIELD TO PIN 21 & COMPACTOR

44 SOLDER SHIELD TO PIN 21 & COMPACTOR

45 SOLDER SHIELD TO PIN 21 & COMPACTOR

46 SOLDER SHIELD TO PIN 21 & COMPACTOR

47 SOLDER SHIELD TO PIN 21 & COMPACTOR

48 SOLDER SHIELD TO PIN 21 & COMPACTOR

49 SOLDER SHIELD TO PIN 21 & COMPACTOR

50 SOLDER SHIELD TO PIN 21 & COMPACTOR

51 SOLDER SHIELD TO PIN 21 & COMPACTOR

FIGURE 12.38

TOLERANCES (EXCEPT AS NOTED)	PS	SCALE	DATE	ISSUE
ORIGINAL	12	2:1	5-16-69	13
FRACTIONAL				
ANGULAR				

VERT. AMP ASSY

HQ.	DESCRIPTION	DATE	REVISION
1	SEC 12.38	4-18-74	1
2	SEE ER-807	3-29-76	2
3	SEE ER-766	11-10-75	3
4	SEE ER-700	12-15-73	4
5	SEE ER-633	10-22-72	5
6	SEE ER-507	4-26-71	6
7	SEE ER-497	4-9-70	7
8	SEE ER-410	11-17-70	8
9	SEE BR-307	3-20-70	9
10	SEE BR-262	1-18-70	10
11	SEE BR-203	7/8/69	11



TP1	TP2	TP3	TP4	TP5	TP6	TP7	TP8	TP9	TP10	TP12
40	41	42	43	44	45	46	47	48	49	50
51	52	53	54	55	56	57	58	59	60	61
62	63	64	65	66	67	68	69	70	71	72

SEE EP-423	SEE EP-196
SEE EP-426	SEE EP-262
SEE EP-427	SEE EP-271
SEE EP-533	SEE EP-339
SEE EP-537	SEE EP-402

QIR NO	PAR NO	AS MNT	PAR NAME
1	40	AS MNT	PC BOARD
2	30309-B		BRACKET COMPT HORIZ
3	5425-A		SOCKET X5.0 OK
4	4055-A		PC BOARD, POT MOUNTING
5	5214-A		SWITCH, JENNINGS 6 POS.
6	5624-A		CONNECTOR BNC
7	54		SOCKET TRANSISTOR
8	10-TBT-3-2		RESISTOR 220 Ω 1/4W 5%
9	10-RRT-3-2		RESISTOR 100 Ω 1/4W 5%
10			
11	1-IBR-32		1K
12	10-TER-32		1500
13	10-LT-32		510 Ω
14	10-TP-32		10K
15	10-YP-32		4700 Ω
16	10-LK-32		3300 Ω
17	10-TB-32		100K
18	1302-A		33.2K 1/4W 1%
19	1303-A		6.81K
20	1304-A		68.1 Ω
21	1305-A		22.1 Ω
22	1306-A		1820 Ω
23	1307-A		332 Ω 1/4W 1%
24	1308-A		8200 Ω 1/4W 5%
25	10-TR-32		RESISTOR 1MEG 1/4W 5%
26			FACTORY SELECTED VALUE 1/4W 5%
27	1812-B		RESISTOR VARIABLE 500 Ω TRIMPOT
28	1808-P		1K TRIMPOT
29	1809-B		10K TRIMPOT
30	1803-B		RESISTOR VARIABLE 2.5 MEG
31	1801-B		RESISTOR VARIABLE 10 K
32	10-TR-32		RESISTOR 120K 1/4W 5%
33	10-TST-32		RESISTOR 150 Ω 1/4W 5%
34	4716-A		2N3646
35	4734-A		2N3440
36			
37	4508-A		DIODE FD 777
38	4511-A		IN60
39	4516-A		IN702
40	4523-A		IN965-B
41	4524-A		IN759-A
42	4525-A		IN756-A
43			
44			
45			
46			
47			
48			
49			
50			

TOLERANCES (EXCEPT AS NOTED)	SCALE	DRAWN BY
DECIMAL	2:1	APPROVED BY
FRACTIONAL		
ANGULAR		
TITLE	HORIZONTAL AMP	
DATE	4 2 57	
QUANTITY	PWD 4039-C	

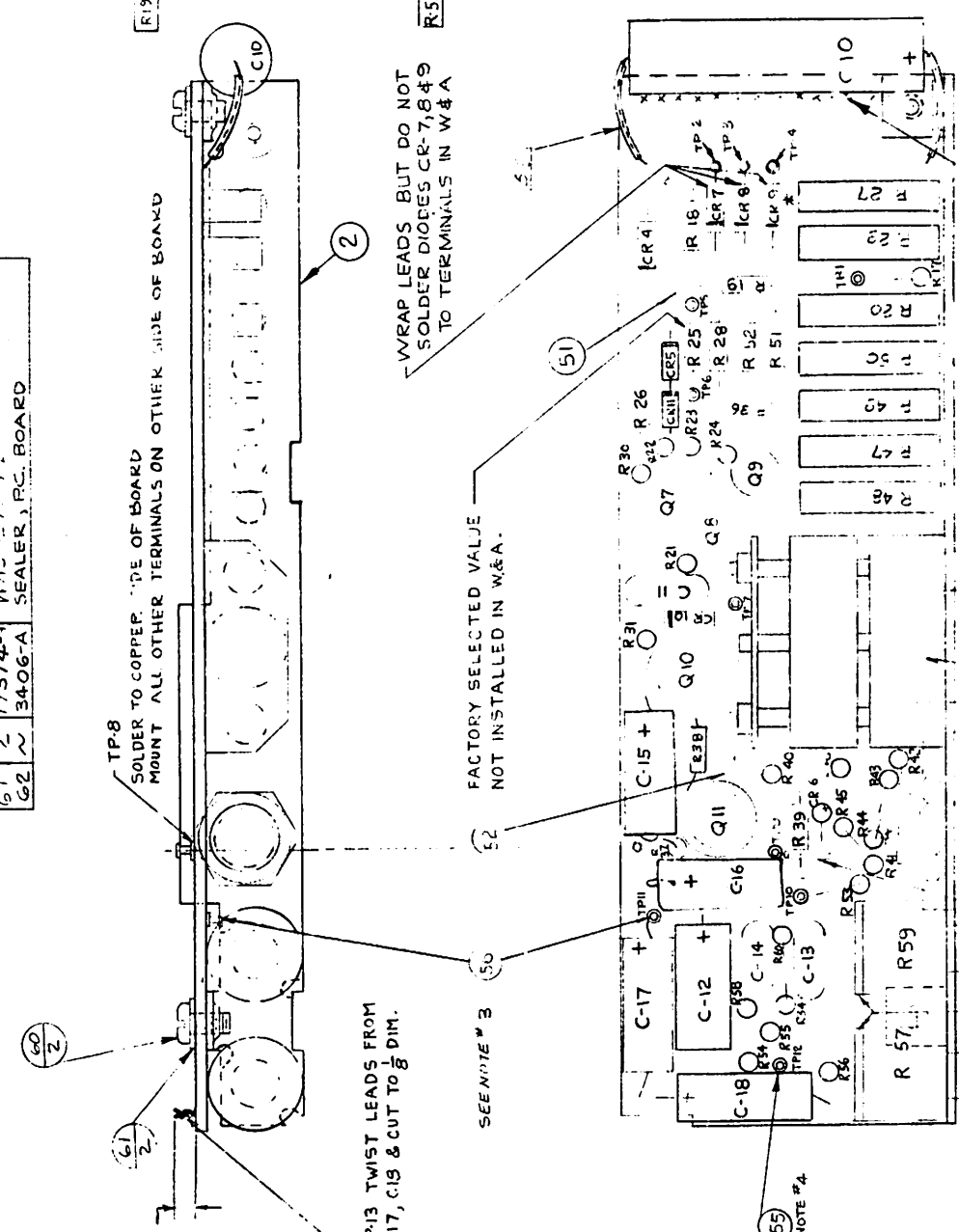

TP13 TWIST LEADS FROM C17, C18 & CUT TO 1/8 DIM.

SEE NOTE #3

WRAP LEADS BUT DO NOT SOLDER DIODES CR-7, 8 & 9 TO TERMINALS IN W & A

FACTORY SELECTED VALUE NOT INSTALLED IN W & A

TP-8 SOLDER TO COPPER SIDE OF BOARD MOUNT ALL OTHER TERMINALS ON OTHER SIDE OF BOARD

TP-13 TWIST LEADS FROM C17, C18 & CUT TO 1/8 DIM.

SEE NOTE #4

TP-13 TWIST LEADS FROM C17, C18 & CUT TO 1/8 DIM.

SEE NOTE #4

TP-13 TWIST LEADS FROM C17, C18 & CUT TO 1/8 DIM.

SEE NOTE #4

EXIT 101...
TRM...

DATE	REVISION RECORD	AUTH.	OR.	CL.
5/1/60	REV. 1
5/1/60	REV. 2
5/1/60	REV. 3
5/1/60	REV. 4
5/1/60	REV. 5
5/1/60	REV. 6
5/1/60	REV. 7
5/1/60	REV. 8
5/1/60	REV. 9
5/1/60	REV. 10

CIR. NO.	PART NO.	PART NAME
1	4077-C	P.C. BOARD (AS MACH.)
2	3031-C	TRANSFORMER CONVERTER
3	3425-B	CHOKES FOR COPE 3-IMP
4	3024-A	...
5	5411-A	...
6	4731-A	...
7	5440-A	...
8	4547-A	...
9	4504-A	...
10	4517-A	...
11	2-10M-015G	CAPACITOR 100NF
12	2-01M-0059	APACITOR .01 MF
13	2-01M-0155	CAPACITOR .01 MF
14	2-01M-0011	CAPACITOR .01 MF
15
16
17	10-RRU-4-2	RESISTOR 2.2 Ω 1/2W
18	22-22-T-8823	WIRE LEAD (R) 2500 V.
19	5436-A	TERMINAL, TUKRET
20	24212-A	TUBING, INSULATING
21	24104-A	TUBING, SHRINKABLE
22	18014-A	NUT, HEX. (NYLON)
23	3209-A	FERRITE BEAD
24	3407-A	POTTING COMPOUND

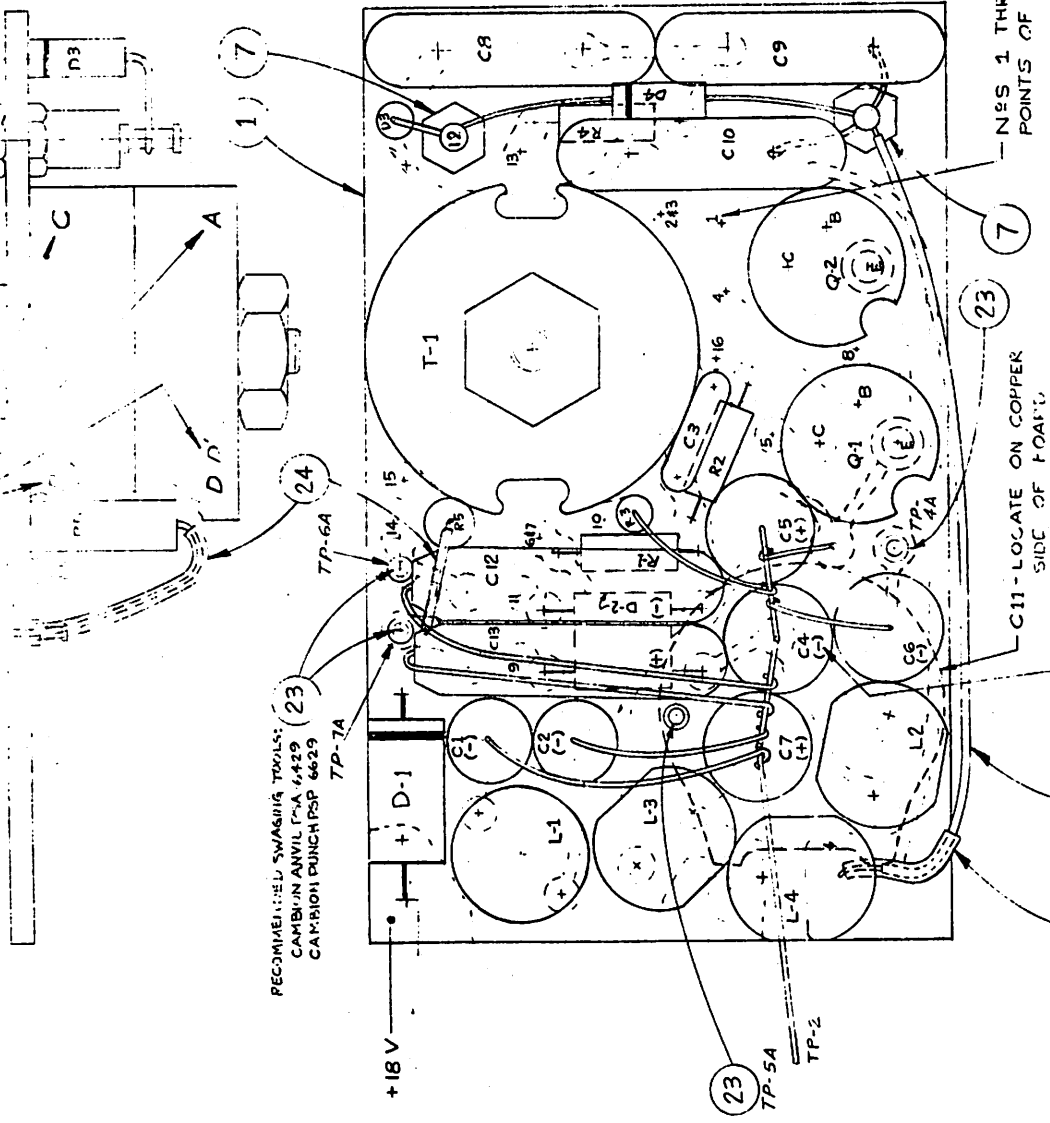

NOTE:
 1. ITEM 22 TO BE 22 GA. WIRES WITH 2500 V. INSULATION,
 WIRE DESIGNATION IN MIL. TYPE HW-C22 (7) U
 (MFG. N° 25-0/22 - DAKOTA)

FIGURE
12-40

TOLERANCES (EXCEPT AS NOTED)	USED CAN T1301A-C	SCALE	DATE BY
DIMENSIONAL	1/1000	4:1	...
FRACTIONAL	1/16		...
ANGULAR	± 1/32		...

TYPICAL ELEVATION OF C-14 Q-2

QTY	QTY	PART NO	PART NAME
1	1	1808-A-C	CASE, PS-10
1	1	5188-B	TRANSFORMER, PS-10
1	1	5188-A	TRANSFORMER, PS-10
1	1	5434-A	HOLDER, FUSE
1	1	5206-A	FUSE
1	1	5207-A	SWITCH, TORSION (DRPT)
1	1	5663-A	CONNECTOR, B.M.C.
1	1	6187-A	POWER CORD
1	1	5701-A	CONNECTOR, STRAIN RELIEF
1	1	440-8-65-53	SCREW, #4-40 x 1/4 LG., PAN HD.
1	1	570-2	WIRE, JUMPER (BW)
1	1	24213-A	TUBING, INSULATED
1	1	440-8-4-558	SCREW, #4-40 x 1/4 LG., PAN HD.
1	1	30417-B	BRACKET, COMPLETE PS-10
1	1	PND-2074-D	PC BOARD ASSEMBLY PS-10
1	1	4735-A	TRANSISTOR (8N1590)
1	1	440-16-5558	SCREW, #4-40 x 1/4 LG., PAN HD.
1	1	17519-A	WASHER, FIBER
1	1	1800-A	NUT, HEX
1	1	24220-A	TUBING, SHRINKABLE
1	1	24-77-4-4-8	WIRE LEAD (PURPLE)
1	1	21059-A	BRACKET, SWITCH STOP
1	1	5483-A	SOLDER LUG
1	1	24-92-4-4-5	WIRE LEAD (RED)
1	1	24-93-4-4-5	WIRE LEAD (ORANGE)
1	1	24-94-4-4-5	WIRE LEAD (YELLOW)
1	1	3422-A	THERMAL COMPOUND

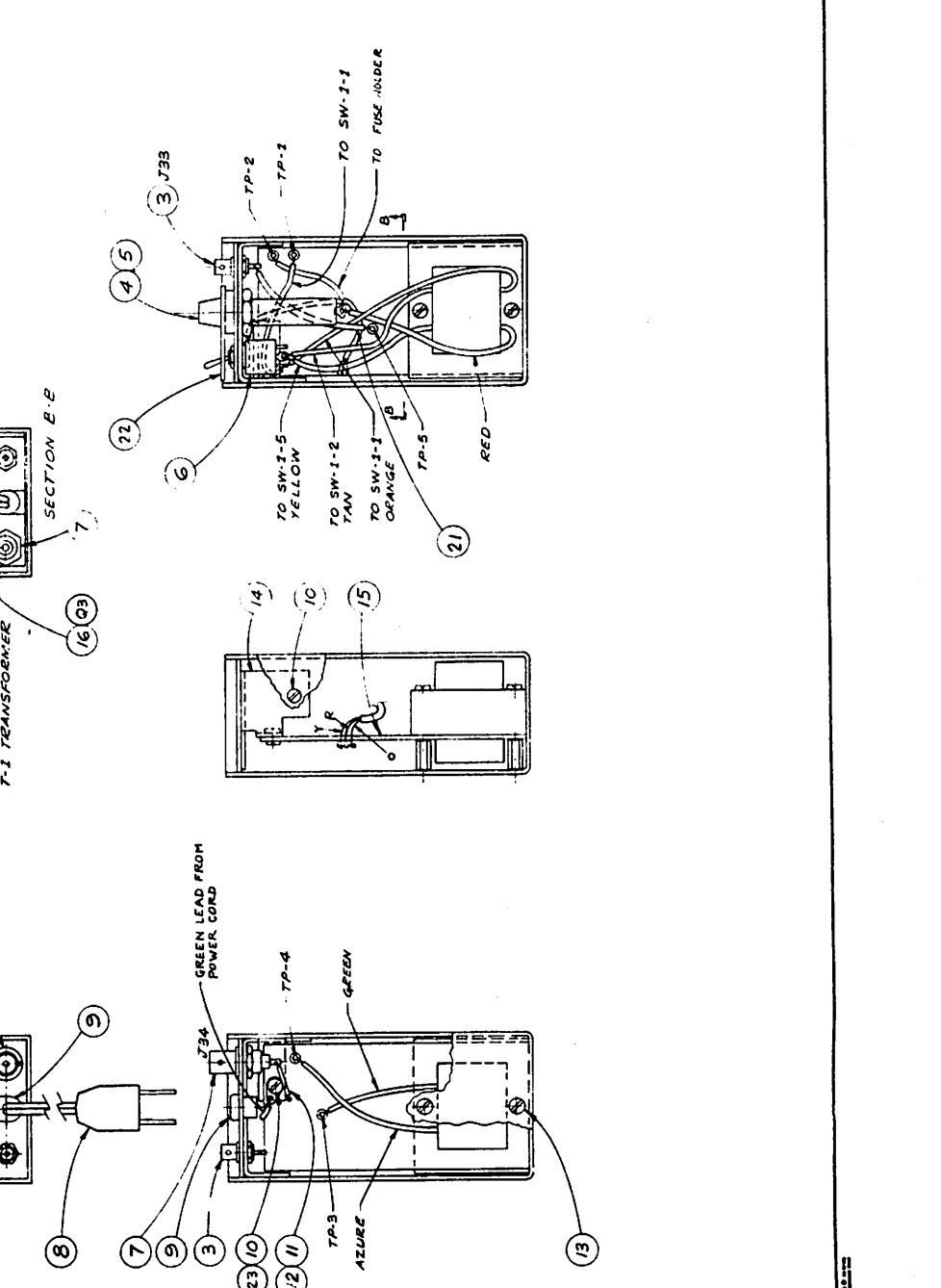
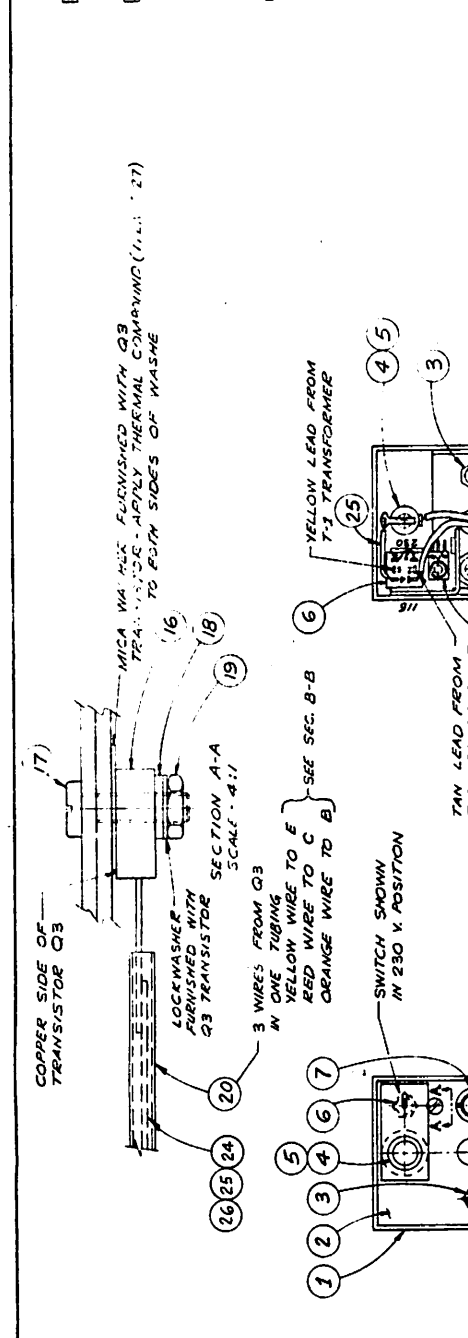

FIGURE 12.41

USED ON	1700-1000	1700-1000	1700-1000	1700-1000
REVISION	1.005	1.005	1.005	1.005
DATE	5/12/71	5/12/71	5/12/71	5/12/71
BY	1700-1000	1700-1000	1700-1000	1700-1000
CHECKED	1700-1000	1700-1000	1700-1000	1700-1000
APPROVED	1700-1000	1700-1000	1700-1000	1700-1000
DESIGNED	1700-1000	1700-1000	1700-1000	1700-1000
TESTED	1700-1000	1700-1000	1700-1000	1700-1000
PREPARED	1700-1000	1700-1000	1700-1000	1700-1000
ISSUED	1700-1000	1700-1000	1700-1000	1700-1000
REVISION	1700-1000	1700-1000	1700-1000	1700-1000
DATE	5-12-71	5-12-71	5-12-71	5-12-71
BY	1700-1000	1700-1000	1700-1000	1700-1000
CHECKED	1700-1000	1700-1000	1700-1000	1700-1000
APPROVED	1700-1000	1700-1000	1700-1000	1700-1000
DESIGNED	1700-1000	1700-1000	1700-1000	1700-1000
TESTED	1700-1000	1700-1000	1700-1000	1700-1000
PREPARED	1700-1000	1700-1000	1700-1000	1700-1000
ISSUED	1700-1000	1700-1000	1700-1000	1700-1000
REVISION	1700-1000	1700-1000	1700-1000	1700-1000
DATE	5-12-71	5-12-71	5-12-71	5-12-71
BY	1700-1000	1700-1000	1700-1000	1700-1000
CHECKED	1700-1000	1700-1000	1700-1000	1700-1000
APPROVED	1700-1000	1700-1000	1700-1000	1700-1000
DESIGNED	1700-1000	1700-1000	1700-1000	1700-1000
TESTED	1700-1000	1700-1000	1700-1000	1700-1000
PREPARED	1700-1000	1700-1000	1700-1000	1700-1000
ISSUED	1700-1000	1700-1000	1700-1000	1700-1000

1700-1000-X

30410-D

5

POWER SUPPLY ASS'Y, PS-10

1700-1000

1700-1000

1700-1000

1700-1000

1700-1000

1700-1000

1700-1000

1700-1000

1700-1000

1700-1000

1700-1000

1700-1000

1700-1000

1	4074-C	AC BOARD AS MACH. 1 PS-10
2	G21-A	CABLE TIE
3	40-3E-25-3S	SCREEN #4 NO.16, BRANDING NO.
4	3030-B	TRANSFORMER, POWER
5	13014-A	SPACER, HEX
6	517-A	TERMINAL, TUBERET
7	3027-A	TRANSFORMER
8	5426-A	SOCKET, TRANSISTOR
9	4729-A	TRANSISTOR 2N3643
10	24213-A	TUBING, INSULATED
11	570-2	WIRE, JUMPER (BW)
12	4731-A	TRANSISTOR 2N2553
13	5443-A	SOCKET, I.C. (8 PIN)
14	4726-A	INTEGRATED CIRCUIT LM308
15	10-890-3-2	RESISTOR 20K
16	10-780-4-2	RESISTOR 1.0 1/4 W 5%
17	10-870-3-2	RESISTOR 24K
18	10-888-3-2	POTENTIOMETER, TRIM 1K
19	10-888-3-2	RESISTOR 2.2K
20	2-500M-049	CAPACITOR SPARGUE 350507663064
21	2-100M-0786	CAPACITOR 100MUF 25V
22	2-25M-0111	CAPACITOR 25MUF 25V
23	2-50P-0059	CAPACITOR 50PF CENTRALAB 00-50C
24	2-1M-0140	CAPACITOR 1MUF 50V CENTRALAB 00-32C
25	2-1000P-0408	CAPACITOR .001 SPARGUE DD-102E
26	2-50M-0041	CAPACITOR .05M 2KV
27	4533-A	DIODE, QUAD MDA-520A-2
28	4532-A	DIODE ZENER 1N969B (ZRC)
29	5419-A	SOLDER LUG
30	12-88-1-1-2	WIRE LEAD (WHITE)
31	14-33-1-1-2	WIRE LEAD (GREEN)
32	9407-A	ROTHING SPRING
33	14467-A	TUBING, SPRING
34	10-787-3-2	RESISTOR 180 1/2
35	16-782-3-2	RESISTOR 1K

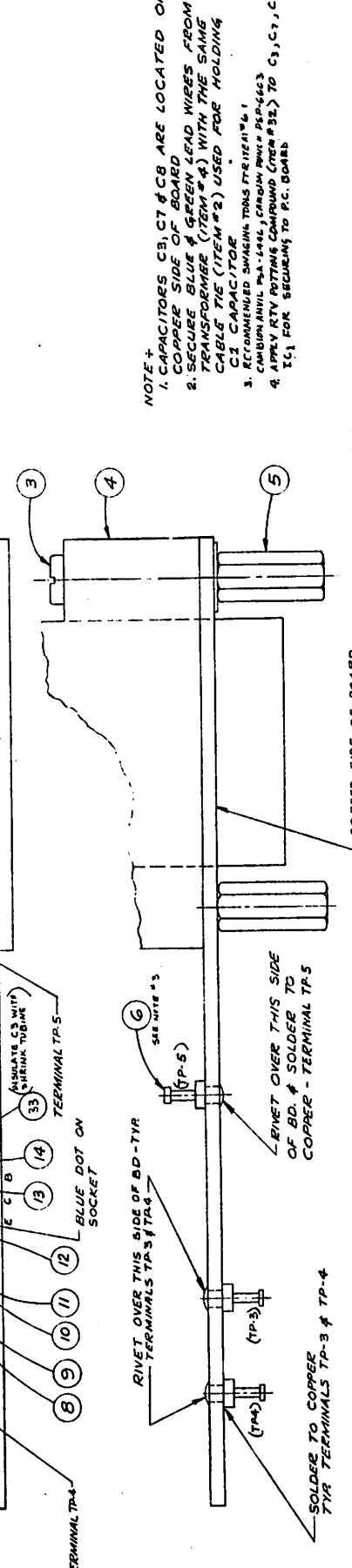
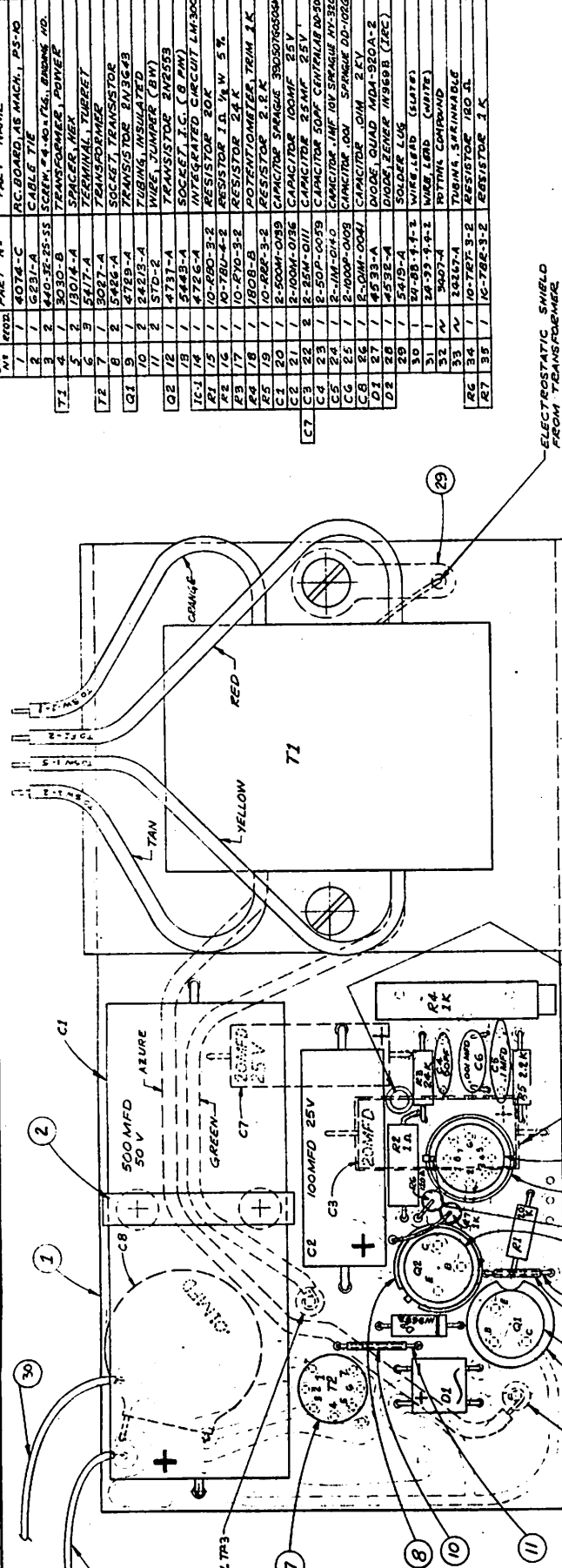

- NOTE +
1. CAPACITORS C3, C7 & C8 ARE LOCATED ON COPPER SIDE OF BOARD
 2. SECURE BLUE & GREEN LEAD WIRES FROM TRANSFORMER (ITEM #4) WITH THE SAME CABLE TIE (ITEM #2) USED FOR HOLDING C1 CAPACITOR
 3. RECOMMENDED SWAGING TOOLS (ITEM #6)
 4. CAMBION ANVIL, PA-1446, CAMBION WIRE # PSP-443
 5. APPLY RTV ROTATING COMPOUND (ITEM #32) TO C3, C7, C8, Q1, Q2, Q4
 6. T.C.1 FOR SECURING TO P.C. BOARD

FIGURE 12.42

USED ON	MANCO ENGINEERING INC
1/EC40-B	PROBULATOR
	DATE 2/77
	REV 2/77
	PC BOARD ASSEMBLY (PS-10)
	3-4-77 PWD-4074-D
	1524

ER-100-X

NOTE:
 1. BATTERY MALLORY RM12 B OR EQUIV. MERCURY / ZINC ALKALINE FOR LOW TEMPERATURES.

CIR NO	PART NO	PART NAME
1	19049-C	CASE BATTERY
2	4075-B	COVER, RIGHT
3	3044-B	COVER, LEFT COMPL.
4	23001-A	SPRINGS
5	6401-A	BATTERY (SEE NOTE 2)
6	5633-A	RECEPTACLE, POWER
7		
8	24088-A	PAD, FELT 2 x 1 1/2
9	832-B/A/28	SCREW #8-32 x 1/4 R. HD
10	440-6-668	SCREW #4-40 x 1/4 PAN HD
11	5872-A	GRAPHIC PANEL PLATE
12	24-22-4-4-3	WIRE LEAD (RED)
13		
14	24-00-4-4-3	WIRE LEAD (BLACK)
15		
16	24248-A	TUBING, SHRINKABLE
17	5438-A	SOLDER LUG

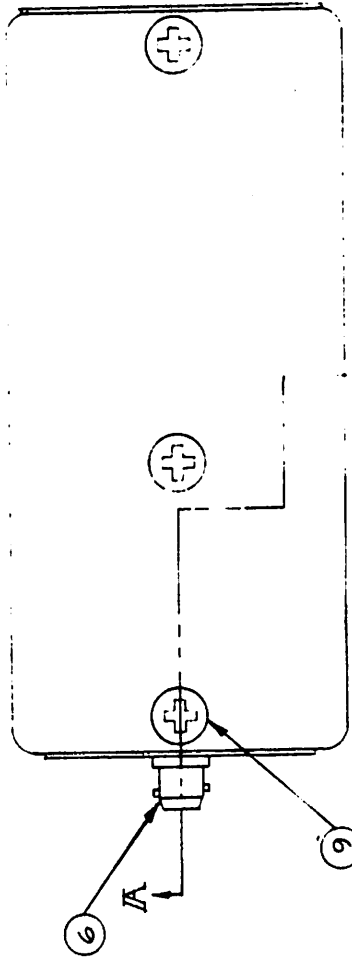

BP-7 SCHEMATIC

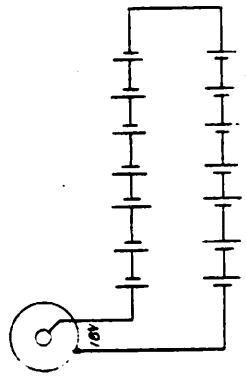

INSTALL BATTERIES PER INSTRUCTIONS ON COVER

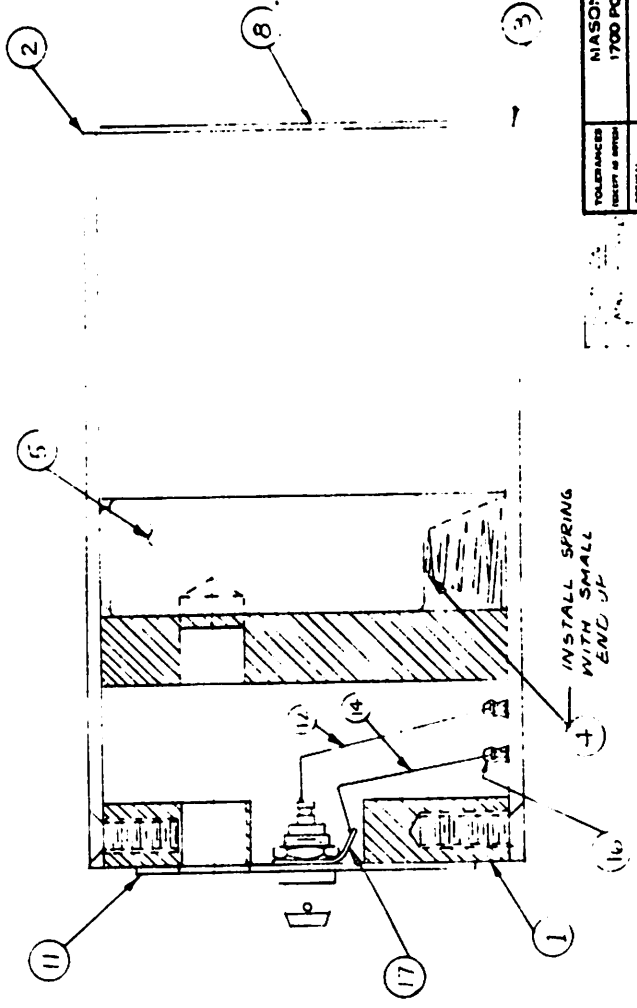

INSTALL SPRING WITH SMALL END UP

SECTION A-A

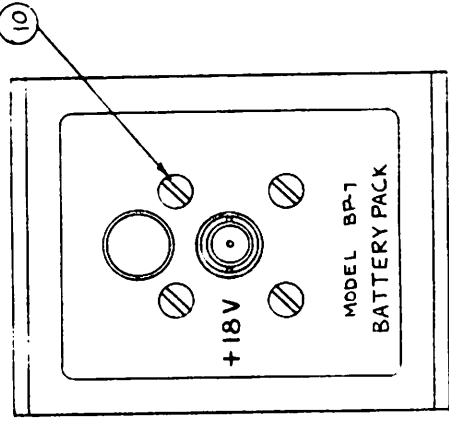

FIGURE 12.43

TOLERANCES UNLESS OTHERWISE SPECIFIED	FRACTIONAL	DECIMAL	ANGULAR
2	2:1		
3			
4			

NASON ENGINEERING INC.
 1700 POST RD. FAIRFIELD, CONN.
 DRAWN BY C.F.M.
 CHECKED BY J.W.Z.
 TITLE BATTERY PACK BP-7 ASSY
 DATE 5 5 11 30460-C
 15570
 2

EN 474



DATE	SYM	REVISION RECORD	AUTH. DR. CK.

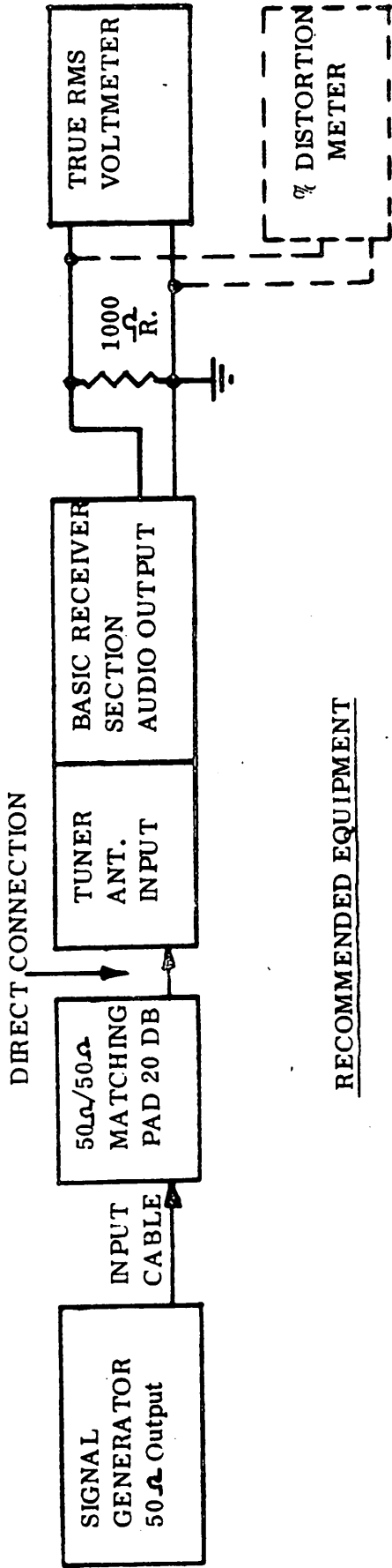

RECOMMENDED EQUIPMENT

SIGNAL GENERATORS	INPUT CABLE	MATCHING PAD	VOLTMETER
TEST RF RANGE	HP MODEL	MEASUREMENTS	HP MODEL 3400 A
2 - 80 KHz	651 B	MODEL M342	TRUE RMS VOLTMETER
.08 - 40 MHz	606 B	20 DB PAD	
or Measurements 82	(TYPE UG-	OR	
40 - 450 MHz	608 E	TEXCAN	
450 - 900 MHz	612 A	MODEL FP 50	
900 - 1600 MHz	8614 A	20 DB PAD	

TOLERANCES (EXCEPT AS NOTED)		MASON ENGINEERING INC.	
DECIMAL	±	SCALE	DRAWN BY
FRACTIONAL	±	APPROVED BY	
ANGULAR	±	TITLE	
		TEST SET UP FOR AM AND FM SENSITIVITY, DIAL ACCURACY, % DISTORTION, SIGNAL METER, TES	
		DATE	DRAWING NUMBER
			FIG-13.1
			ISSUE
			1

1700 POST RD. FAIRFIELD, CONN.

DATE	SYM	REVISION RECORD	AUTH.	DR.	CK.

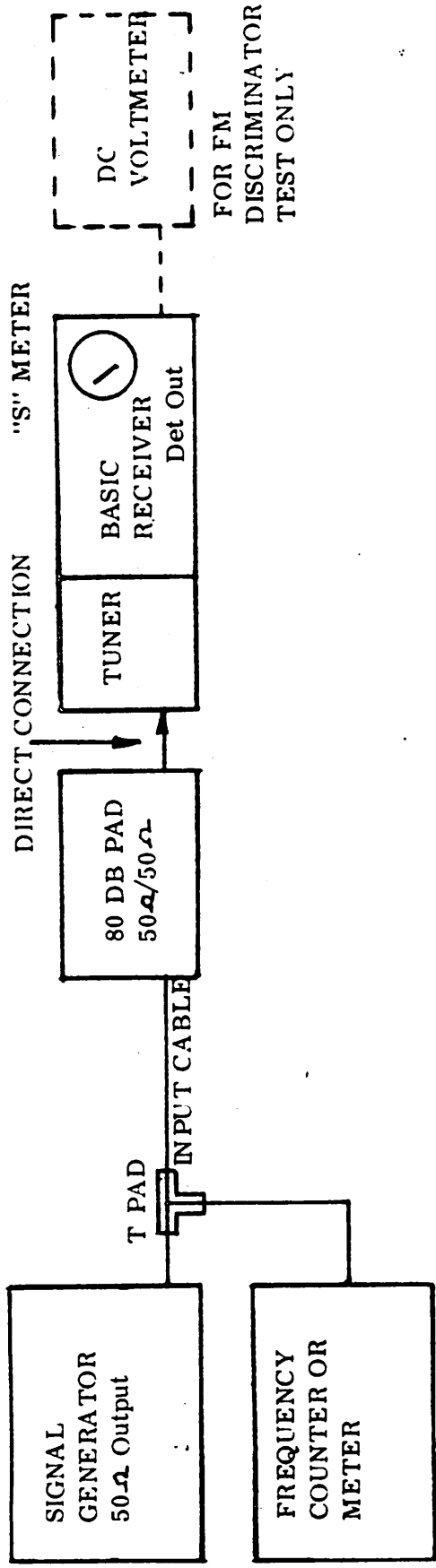

RECOMMENDED "T" PAD: MEASUREMENTS MODEL # M-501 (6 DB LOSS)

TOLERANCES (EXCEPT AS NOTED)		MASON ENGINEERING INC. 1700 POST RD. FAIRFIELD, CONN.	
DECIMAL	±	SCALE	DRAWN BY
FRACTIONAL	±		APPROVED BY
ANGULAR	±	TITLE TEST SETUP FOR BANDWIDTH AND SLOPE FACTOR FM DISCRIMINATOR, BANDSPREAD, TESTS	
		DATE	DRAWING NUMBER
			FIG-13.2
			ISSUE
			1

DATE	SYM	REVISION RECORD	AUTH.	DR.	CK.

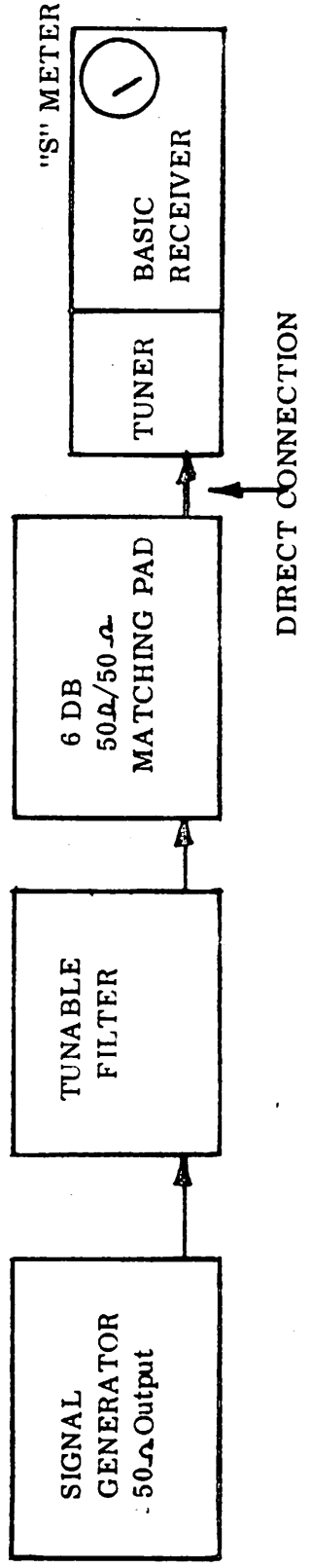

RECOMMENDED TUNABLE FILTER MANUFACTURERS:
 KHRONHITE, TELONIC, RADIO FREQUENCY LABORATORIES.

SEE FIGURE 13.1 FOR OTHER RECOMMENDED EQUIPMENT.

TOLERANCES (EXCEPT AS NOTED)	MASON ENGINEERING INC. 1700 POST RD. FAIRFIELD, CONN.	
DECIMAL	SCALE	DRAWN BY
FRACTIONAL		APPROVED BY
ANGULAR	TITLE	DATE
	TEST SETUP FOR SPURIOUS RESPONSE TESTS	DRAWING NUMBER
		FIG-13.3
	ISSUE	1

DATE	SYM	REVISION RECORD	AUTH.	DR.	CK.

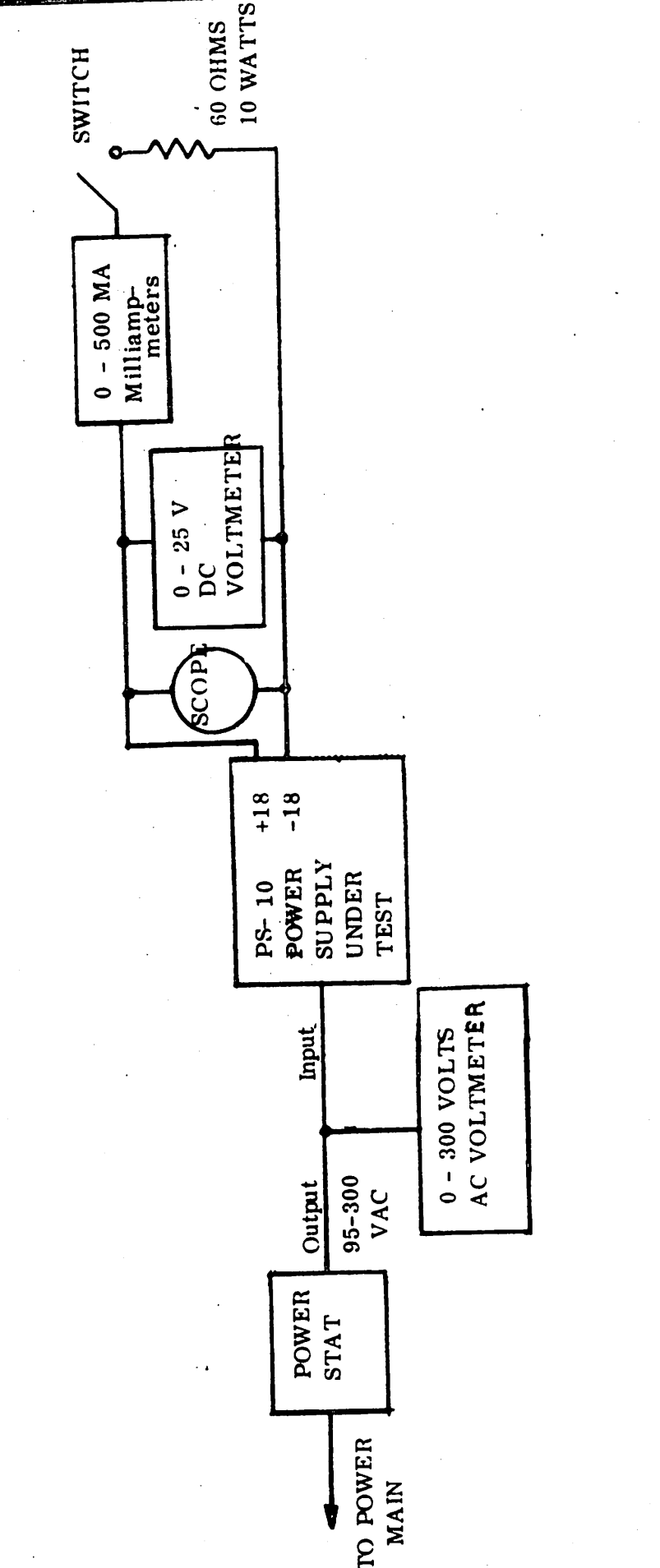

TOLERANCES (EXCEPT AS NOTED)		MASON ENGINEERING INC. 1700 POST RD. FAIRFIELD, CONN.	
DECIMAL	±	SCALE	DRAWN BY
FRACTIONAL	±	APPROVED BY	
ANGULAR	±	TITLE	
DATE	DRAWING NUMBER	TEST SET UP FOR POWER SUPPLY TESTS	
	FIG-13.4	ISSUE	
		1	

DATE	SYM	REVISION RECORD	AUTH.	DR.	CK.

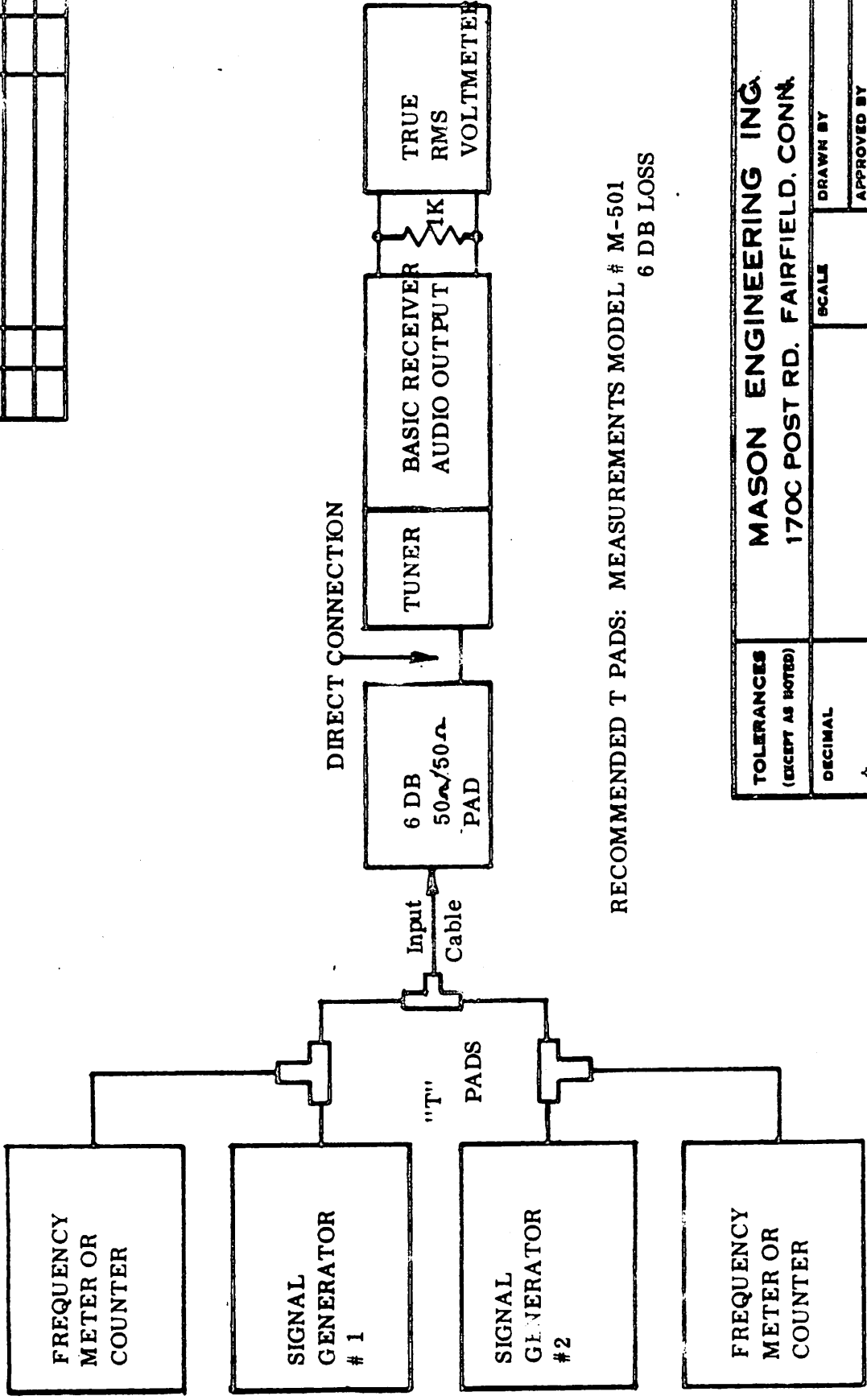

RECOMMENDED T PADS: MEASUREMENTS MODEL # M-501
6 DB LOSS

TOLERANCES (EXCEPT AS NOTED)		MASON ENGINEERING INC. 170C POST RD. FAIRFIELD, CONN.	
DECIMAL	±	SCALE	DRAWN BY
FRACTIONAL	±	DATE	APPROVED BY
ANGULAR	±	TITLE	ISSUE
		TEST SET UP FOR CW DESENSITIZATION TEST	1
		DRAWING NUMBER	FIG-13.5



12/74

A3 DATA SHEET 14-A

BY

DATE

S/N

		AM SENSITIVITY 10 DB			FM QUIETING 20 DB			DIALS *	
		8.1		$\frac{S+N}{N}$	8.2		8.1		
TUNER	RF MHz	IF BW KHz	REQ AM SENS UV	MEAS. SENS. UV	IF BW KHz	REQ FM SENS UV	MEAS. SENS UV	REQ - KHz	MEAS.
T 03	.002	.2	1.5/4M		-----NA-----			1/8"	
	.100	2	1.5		2	3		1.5	
	.300	2	1.5		2	3		4.5	
T 1	.3	20	1.5		20	5		4.5	
	.6	20	1.5		20	5		9	
	1.0	20	1.5		20	5		15	
T 2	1.0	20	1.5		20	5		MHz .015	
	2.0	20	1.5		20	5		.03	
	3.5	20	1.5		20	5		.05	
T 3	3.5	20	1.5		20	5		.05	
	8.0	20	1.5		20	5		.12	
	12.0	20	1.5		20	5		.18	
T 4	12	20	1.5		90	7		.18	
	20	20	1.5		90	7		.3	
	43	20	1.5		90	7		.6	
T 5	43	20	1.5		90	7		.6	
	80	20	1.5		90	7		1.2	
	130	20	1.5		90	7		1.9	
T 6A	130	20	2		90	7		1.9	
	160	20	2		90	7		2.4	
	230	20	2		90	7		3.4	
T 6B	230	20	2		90	7		3.4	
	300	20	2		90	7		4.5	
	420	20	2.5		90	7		6.3	
T 7	420	90	2.5		90	10		6.3	
	600	90	2.5		90	10		9.0	
	800	90	2.5		90	10		12.0	
T 8	800	90	3.5		90	15		12	
	1200	90	3.5		90	15		18	
	1600	90	3.5		90	15		24	
EXT	111	90	1.0						

* or 1/8 inch dial displacement. T1 dial measured in 2 KHz BW position

BY DATE S/N

	TUNER	03	1	2	3	4	5	6A	6B	7	8
	RF MHz	.100	.6	2	8	20	80	160	300	600	1200
	MIN. BS REQ. KHz	NA	1.2	4	16	40	160	320	600	120	240
8.3	BS	NA									
	SPUR. REJ. REQ. DB	50	80	80	80	50	50	40	40	40	40
	IF FREQ.	455	23.5	23.5	23.5	111	23.5	111	111	111	111
8.4	IF REJ. IMAGE FREQ.	1.01	47.6	49	55	242	127	382	522	822	1422
8.5	IMAGE REJ.										

8.6	FM OUTPUT	Test	FM Dev.	RF	IN	Level IN	Audio Out	Level
			Set					
		20 KHz BW FM NAR	4 KHz	10 MHz	T-3	10 uv	.3 v	
		90 KHz BW FM NAR	20 KHz	23.5	Wide Bl	1 mu	1.0 v	
		90 KHz BW FM WIDE	20 KHz	23.5	Wide Bl	1 mu	.5 v	
		1 MHz BW FM WIDE	65 KHz	23.5	Wide Bl	1mu	1.0 v	

8.7 IF BANDWIDTH

- LFR .2 KHz IF, 60 KHz RF, between 180 and 250 Hz _____
- LFR 2 KHz IF, 60 KHz RF, between 1.8 and 3.5 KHz _____
- LFR 10 KHz IF, 60 KHz RF, between 9 and 13 KHz _____
- HFR, 2 KHz, 600 KHz RF, between 1.8 and 3.5 KHz _____
- HFR, 20 KHz, 600 KHz RF, between 18 and 24 KHz _____
- HFR, 90 KHz, IF output wide jack, between 70 and 120 KHz _____
- HFR, 1 MHz, IF output wide jack, between 1 and 2 MHz _____

8.8 SWEEP WIDTH PANADAPTER MODE

SWEEP WIDTH POSITION	SWEEP WIDTH TEST			CENTERING TEST		
	RF TEST FREQ.	SWEEP WIDTH LIMITS	SWEEP WIDTH	RF TEST FREQ.	BW	CENTERED
500 KHz/Div.	50 MHz	450 - 550 KHz/Div.		50 MHz	2 KHz	
120 KHz/Div.	50 MHz	100 - 140 KHz/Div.		50 MHz	2 KHz	
30 KHz/Div.	50 MHz	25 - 35 KHz/Div.		50 MHz	2 KHz	
6 KHz/Div.	600 KHz	5 - 7 KHz/Div.		50 MHz	2 KHz	
1 KHz/Div.	600 KHz	.5 - 1.5 KHz/Div.		50 MHz	2 KHz	
.3 KHz/Div.	600 KHz	.2 - .5 KHz/Div.		50 MHz	2 KHz	

8.8 (Cont.) SWEEPWIDTH T-03 MODE

25 Kc/Div.	100 KHz	20-30 KHz		100 KHz	2 KHz	
6.5 Kc/Div.	100 KHz	5.0 - 7.5 KHz		100 KHz	2 KHz	
2 Kc/Div.	100 KHz	1.0 - 2.5 KHz		100 KHz	2 KHz	
.350 Kc/Div.	100 KHz	250 - 450 Hz		100 KHz	.2 KHz	
.090 Kc/Div.	100 KHz	50 - 100Hz		100 KHz	.2 KHz	

8.9 SWEEP RATE

SWEEP RATE POSITION	FREQUENCY REQUIREMENTS		FREQUENCY
1.5/6 us	66.6	16.6 KHz	
6/30 us	16.6	3.3 KHz	
30/135 us	3.3	.74 KHz	
135/700 us	740	143 Hz	
.7/4 ms	143	25 Hz	
4/20 ms	25	5 Hz	
20/100 ms	5	1 Hz	

11/76

BY

DATE

S/N

A3 DATA SHEET 14-D

CHECK LIST

8.	ITEM	
10	S3	VERT SENS (1 MV/DIV)
11	S3	SIG GAIN CONTROL (50 dB)
12	S3	SIG BW (1 Hz - 1.8 MHz)
13	S3	Z AXIS SENS (40 V PP)
14	S3	BRIGHTNESS CONTROL
15	S3	FOCUS CONTROL
16	S3	SWP. CENTERING CONTROL
17	S3	SIG. CENTERING CONTROL
18	S3	SYNC CONTROL
19	S3	EXT SYNC INPUT JACK
20	S3	SWP GAIN CONTROL
21	LFR	HI-LOW METER SWITCH
22	LFR	IF GAIN CONTROL
23	LFR	AGC TEST JACK(+4.2/5.2 V. No Sig) +3.0V at .1V sig)
24	LFR	DET OUT JACK
25	LFR	AUDIO OUTPUT (2.5 V out/ 5 uv in)
26	LFR	IF OUT JACK
27	LFR	BFO
28	HFR	HI-LOW METER SWITCH
29	HFR	IF GAIN CONTROL
30	HFR	AGC TEST JACK(+4.2/5.2V No sig, > +3.0V at .1V sig)
31	HFR	DET. OUT AND SWP JACK
32	HFR	AUDIO OUT (2.5 V out/ 5 uv in)
33	HFR	BFO
34	BP-7	ONE & TWO OPERATE
35		ACCESSORY CHECK OUT

Quantity	Item	Quantity	Item
1	Earphone with cord	1	Remote Tuner Cable
1	Whip Antenna	1	Manual
1	Bow Tie Antenna with extenders	1	Tool, common screwdriver
1	Ferrite Rod Antenna #1 (2-300 KHz)	1	Tool, Phillips Screwdriver
1	Ferrite Rod Antenna #2 (.3-30 MHz)	1	Allen wrench
1	Long Wire Antenna	1	Spline Key
1	Blocking Capacitor	1	Attache Case
2	20 dB Attenuator Pad	1	Attache Case insert #1 Lower
1	BNC Male/Male adapter	1	Attache Case insert #2 Lid, large
1	BNC Female/Female adapter	1	Attache Case insert #3 Lid, small
1	European Power plug adapter #1	2	Attache Case insert #4 (S3 Pads)
1	European Power plug adapter #2	1	Interconnecting harness
1	Five foot BNC cable	1	Spinner knob
1	One foot BNC cable	1	Antenna Mast
1	Power Cable		
1	2 to 3 wire ac adapter		